

Wireless World

RADIO AND ELECTRONICS

APRIL

1948

38th YEAR OF PUBLICATION

Proprietors : ILLIFE & SONS LTD
Managing Editor : HUGH S. POCOCK, M.I.E.E.
Editor : H. F. SMITH

Editorial, Advertising and Publishing Offices :
DORSET HOUSE, STAMFORD STREET,
LONDON, S.E.1.

Telephone : Waterloos 3333 (60 lines).
Telegrams : "Ethaworld, Sedist, London."

PUBLISHED MONTHLY
Price : 1/6

(Publication date 26th of preceding month)

Subscription Rate : 20/- per annum. Home and Abroad

Branch Offices :

Birmingham : King Edward House, New Street, 2.
Coventry : 8-10, Corporation Street.
Glasgow : 26B, Renfield Street, C.2.
Manchester : 260, Deansgate, 3.

In this Issue

EDITORIAL COMMENT	119
TELEVISION E.H.T. SUPPLY By A. H. B. Walker	120
SHORT-WAVE CONDITIONS	125
PUSH-PULL INPUT CIRCUITS—4 By W. T. Cocking	126
PROGRESS IN COMPONENTS	131
TELEVISION TEST PATTERN	137
A.C. BRIDGES By "Cathode Ray"	139
WORLD OF WIRELESS	143
UNBIASED By "Free Grid"	147
ATLANTIC CITY	148
NEW BOOKS.. .. .	151
LETTERS TO THE EDITOR	153
MANUFACTURERS' PRODUCTS	154
RANDOM RADIATIONS By "Diallist"	156
RECENT INVENTIONS	158

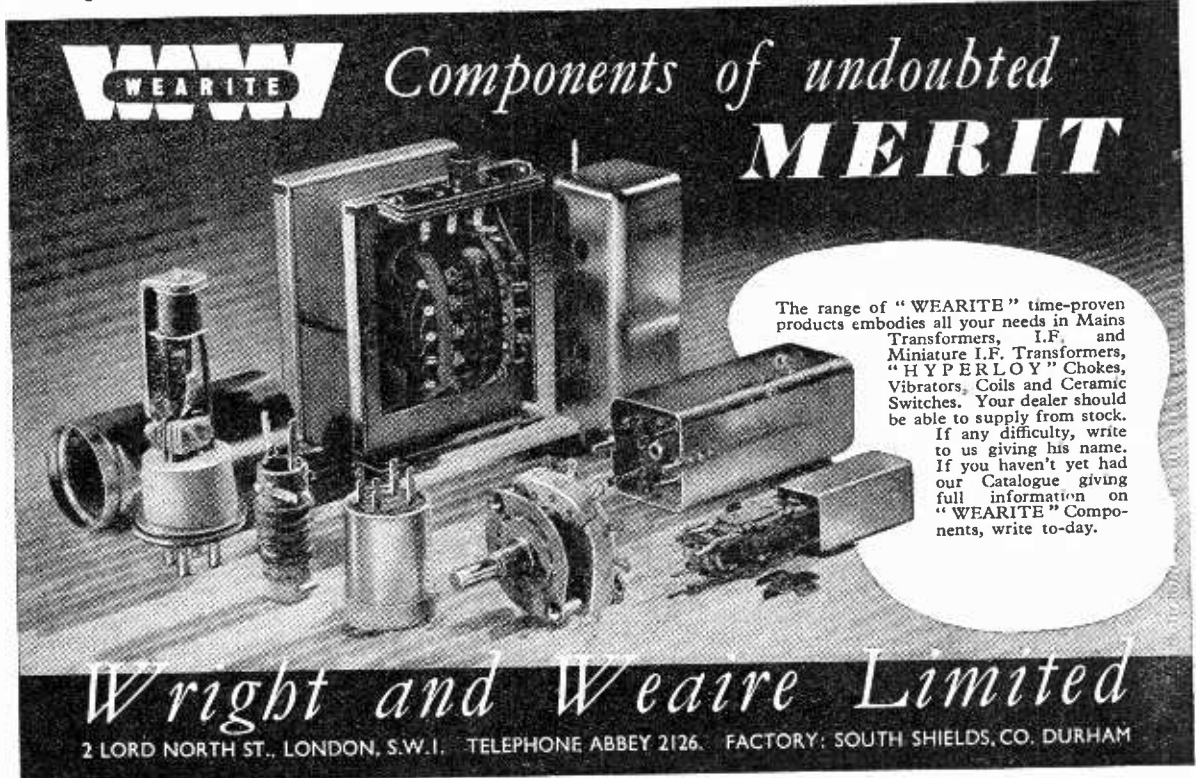

WEARITE Components of undoubted **MERIT**

The range of "WEARITE" time-proven products embodies all your needs in Mains Transformers, I.F. and Miniature I.F. Transformers, "HYPERLOY" Chokes, Vibrators, Coils and Ceramic Switches. Your dealer should be able to supply from stock. If any difficulty, write to us giving his name. If you haven't yet had our Catalogue giving full information on "WEARITE" Components, write to-day.

Wright and Weaire Limited
2 LORD NORTH ST., LONDON, S.W.1. TELEPHONE ABBEY 2126. FACTORY: SOUTH SHIELDS, CO. DURHAM



VALVES AND THEIR APPLICATIONS

By M. G. SCROGGIE, B.Sc., M.I.E.E.

No. 16: Mullard System of Type Nomenclature for Transmitting Valves

THE system of Mullard valve nomenclature explained last month is designed for receiving valves. For transmitting valves, the information one wants to know first is not quite the same. For example, the type of base is rather a detail when the valve itself is a comparatively substantial item. Moreover, transmitter bases are not so distinctly classified as receiver bases; often they are just clamps to hold the valve in position. So they are not specified in the symbols. Nor are filament voltages and currents, for they too are more or less unstandardized. On the other hand, the general type of cathode is important; and the anode voltage and output power even more so.

The form in which the output power is best specified depends to some extent on the class of valve. ("Transmitting" valves, by the way, include rectifiers, and of course valves used for purposes other than transmitting, such as audio amplification and R.F. heating). The limiting factor for rectifiers is most suitably expressed as the maximum rectified current. Most power valves are limited primarily by the maximum wattage that can be dissipated by the anode. As this is not so with large water-cooled valves dissipating over 5kW, they form a separate class in which the power specified is the output power.

The form of nomenclature used for receiving valves (consisting of two—or possibly three—letters followed by two or more figures) is retained, with appropriately different meanings:

FIRST LETTER: General Class of Valve.

M	L.F. power amplifier or modulator triode.	} <i>These are easy. If "Q" looks queer for "tetrode" has first claim to "T", and "Quatre" is French for 4.</i>
P	R.F. power pentode.	
Q	R.F. power tetrode.	
R	Rectifier.	
T	R.F. power triode.	

SECOND LETTER: Type of Cathode.

G	Oxide-coated filament in mercury-vapour rectifier.
V	Indirectly-heated oxide-coated cathode.
X	Directly-heated pure tungsten filament.
Y	Directly-heated thoriated tungsten filament.
Z	Directly-heated oxide-coated filament (except in mercury-vapour rectifiers).

THIRD LETTER: "S" indicates Silica Envelope.

FIRST NUMBER: Anode Voltage in Kilovolts.

E.g.: 05 means 0.5 kV=500V.

1 means 1 kV=1,000 V.

5 means 5 kV.=5,000 V.

12 means 12 kV=12,000 V. and so on.

SECOND NUMBER: Output.

- For valves up to 5 kW anode dissipation, the figures indicate the maximum permissible anode dissipation in watts.
- For water-cooled valves over 5 kW dissipation, the figures indicate the maximum output in kilowatts.
- For rectifiers, the figures indicate the maximum permissible rectified current per valve in milliamps.

Note:—A further letter, A or W, may follow the valve type number, to indicate whether the valve is forced air cooled or water cooled.

Examples:—

QV04-7 R.F. power tetrode with indirectly-heated oxide-coated cathode. Anode rated to work at 400 V and dissipate 7 watts continuously.

TX12-20W R.F. power triode, water-cooled, with tungsten filament. Anode rated to work at 12,000 V, for an output of 20 kW.

RG3-250 Mercury-vapour rectifier with a rated anode voltage of 3,000, giving a maximum rectified output of 250 mA.

There are one or two exceptional valves for which the code has had to be modified, but normally it holds good.



This is the sixteenth of a series written by M. G. Scroggie, B.Sc., M.I.E.E., the well-known Consulting Radio Engineer. Reprints for schools and technical colleges may be obtained free of charge from the address below. Technical Data Sheets on all types of valves are also available.

**THE MULLARD WIRELESS SERVICE CO. LTD.,
TECHNICAL PUBLICATIONS DEPARTMENT,
CENTURY HOUSE, SHAFESBURY AVE., WC2.**

Wireless World

RADIO AND ELECTRONICS

Vol. LIV. No. 4

April 1948

Components for Export

THE vigour and flexibility of the components section of the British radio industry was well exemplified at the recent London exhibition organized by the Radio Component Manufacturers' Federation: the show is reported at some length elsewhere in this issue. By common consent, it was by far the best, both in diversity and interest of exhibits, as well as in detail organization, that has yet been staged. It must have convinced the foreign buyer—who appeared to be represented in large numbers—that our manufacturers cannot be ignored.

It is a fortunate circumstance that almost all the vast range of circuitry—which is, after all, the very essence of radio and electronics—can be set up with an extremely limited range of more or less standard components. With resistors and capacitors of a score or so of "preferred" values and two or three ratings, a few inductors and a small collection of more specialized parts, there is hardly any limit to what can be done. The fact that new arrangements can be put into effect so easily has undoubtedly been an important factor in the growth of our art. Standardization of components became established to a useful extent even before any conscious effort to achieve it was made. Since its real importance was realized constant efforts have been made to achieve greater uniformity; one of the good things that came out of the war was a notable advance in this direction. But we believe that still more standardization is necessary in order that production may reach higher levels combined with the greatest possible economy. This is a matter in which there must be co-operation between makers and users of components. The organization for ensuring this co-operation already exists, and we hope it will grow. Increasing standardization—of the right sort—will make for more efficiency in production for home use, and will give an advantage on the export market. In the latter market the contribution of component manufacturers is already considerable, and it is

likely to become greater. A refreshing tendency, evident at the Exhibition, was to give the foreign buyer the kind of thing he wanted, rather than that judged to be good for him.

We are not suggesting that the maker of components should pander to the demand for cheap and nasty products. During the war, when cost did not matter, he learned to make things to a much higher standard than ever before; since the war he has learned in many cases that high quality and low production costs are not entirely irreconcilable. We observe with pleasure a distinct reluctance to depart from the high standards to which the industry has become accustomed. It would be a pity if the reputation that has been acquired should be lost.

A Virtually New Field

Makers of components are usually quick to react to the demand for products of new kinds, and a number of parts suitable for low-powered communication equipment were to be seen at the exhibition. But this is a side of radio that is making great advances at present, both at home and abroad, and we think that still more specialized components are needed; if a large measure of standardization of their design can be achieved, so much the better, as it will help to keep down costs, and so lead to still wider applications of what the G.P.O. calls "business radio."

At the opening of the R.C.M.F. exhibition the Minister of Supply stressed the need for increasing standardization, and promised in return that the Government would do its best to help the industry to sell its products in overseas markets. The industry has indicated that it would welcome Government help in securing its share of import quotas in countries which cannot at present accept its products; it would also benefit by a more rapid extension of our home television service. We think that the industry, by its own efforts, has shown itself to be worthy of Government support.

MANY new problems have been introduced by the need for high D.C. voltages—in the order of 5kV—in television receivers. One of the most troublesome was, and still is, that of producing small, light and inexpensive transformers which will operate reliably at these voltages in the high temperatures and heavy dust deposits of the average domestic television receiver. The problem is becoming more acute at the present time owing to the continued trend towards ever-higher voltages in domestic equipment. While existing 9in and 12in tubes will give reasonably bright pictures at anode potentials of 4 kV and 5 kV, new developments on aluminium-backed phosphors will probably increase these voltages to the order of 7 or 8 kV, while special small high-brilliance tubes suitable for optical image projection, will probably require anode potentials of 25 or even 50 kV. Thus it is not surprising that there is much investigation in progress towards solving this E.H.T. supply problem, and it is the object of this article briefly to review some of the alternative methods, and in particular to draw attention to the way in which recent developments in high-voltage metal rectifiers have opened up possibilities hitherto impracticable on physical or economic grounds.

E.H.T. Supply Requirements.

Before comparing alternative

Television E.H.T.

I.—Required Characteristics : Survey

By **A. H. B. WALKER, B.Sc. (Hons.), A.M.I.E.E.**

(Research Laboratory, Westinghouse Brake and Signal Company)

how important is the performance of the E.H.T. supply, nor how "good" it should be for acceptable results.

Since the tube beam current is drawn from the E.H.T. supply, and (apart from safety discharging resistors) constitutes the total load on it, this load current is modulated over the whole band of video frequencies, and moreover, since the D.C. component of the video signal has been either preserved or restored at the grid of the cathode-ray tube, the band of frequencies extends right down to zero frequency or D.C. This, one might say, should cause no difficulty provided that the power pack can supply the maximum load. Unfortunately, two other important factors, namely, the beam focus and the beam "stiffness" or deflection sensitivity, are also affected by the electron velocity which is dependent on the E.H.T. voltage. To avoid upsetting the focus or the picture size it is therefore essential to maintain the E.H.T. voltage constant and independent of beam current variations (a) at both high and low

mean D.C. load current. The first requirement can readily be met by terminating the E.H.T. supply with a reservoir capacitor sufficiently large to provide an adequate time constant with the equivalent resistance presented by the tube anode when carrying peak white beam current. This time constant must be long compared with the time of one frame scan period, and this is easily achieved. Consider, for example, a tube operating at 5 kV with a peak white beam current of 100 microamperes; then the equivalent tube resistance equals 50 MΩ, and if we aim at a time constant (RC) of five times the frame scan period, or 0.1 second, then

$$C = \frac{0.1}{50} \approx 0.002 \mu F$$

In actual practice, except for high-frequency E.H.T. supplies, a larger capacitance than this is likely to be used in any case for smoothing purposes, so that (a) above does not usually cause any difficulty.

However, all forms of E.H.T. power supply have internal resist-

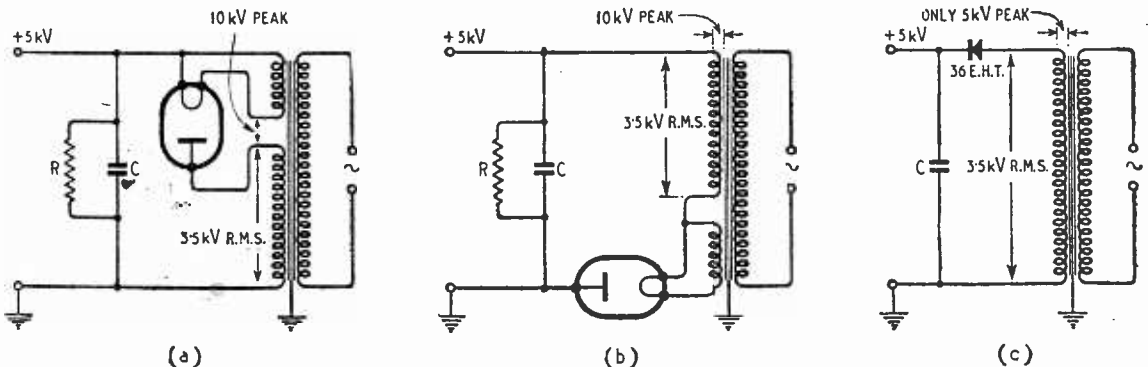

Fig. 1. Half-wave rectifier circuits all developing 5 kV. In (a) 10 kV peak appears between windings, in (b) 10 kV peak between windings and core, in (c) the peak is reduced to 5 kV by elimination of the heater winding

methods, it is essential to set out the performance to be achieved; it is perhaps not generally realised

video frequencies, and (b) (more difficult) at very low frequencies extending down to changes in

ance, so that no increase in smoothing capacitance will deal with the problem of maintaining

Supply

Existing Methods

a constant E.H.T. voltage with changes in the mean D.C. load current. In order to define a tolerable limit to this D.C. "regulation" and to simplify the comparison between different forms of power supply, it is convenient to refer to the regulation as the percentage change in E.H.T. voltage for a mean load current change of 100 microamperes, as this represents typical operating conditions fairly well. A regulation of 10 per cent per 100 μ A change is a rough outside limit for a reasonable result on a directly viewed tube, while a figure of 1 per cent or 2 per cent will probably be necessary for projection equipment.

The remaining performance criterion is residual ripple on the E.H.T. supply. Where the transmitter frame scan frequency is locked to the mains supply, a certain amount of ripple can be tolerated, since stationary hum and defocus bands are not very noticeable. The B.B.C. is attempting to ensure frame frequency synchronisation to the electricity grid for all outside broadcasts, but as this may not always be possible, a low percentage ripple is desirable to avoid the confusion of moving hum bands on these occasions, and also to remove at least one easily avoidable cause of distortion from the normal studio picture. In practice, a figure of 2 per cent ripple gives acceptable results.

Effects of E.H.T. Shortcomings.

The screen effects produced by these faults are all easily recognizable. Apart from hum bands, too short a time constant in the E.H.T. supply will cause defocusing of parts of the picture, but this effect can easily be distinguished from bad focus, since the poorly focused parts will move with the picture; and further, if the left- and right-hand edges of the picture are examined they will be found to be wavy instead of straight, moving "bulges" occurring on the same

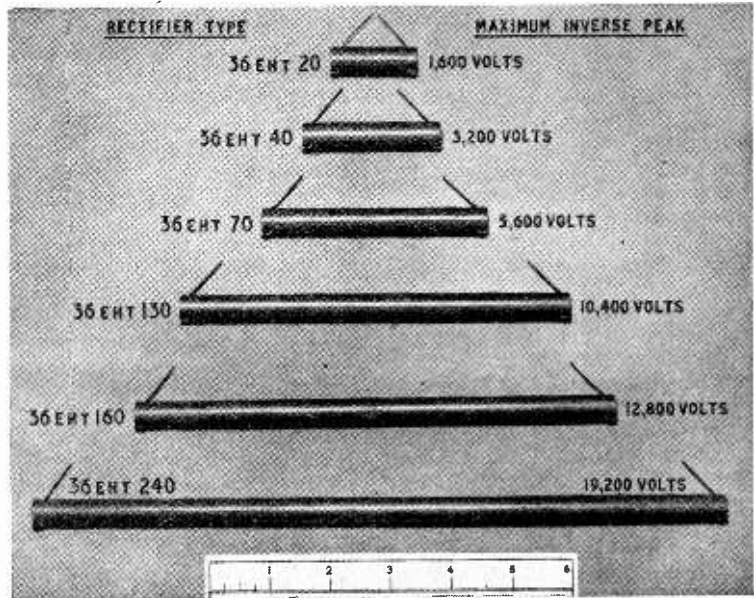

Examples of new 36EHT high-voltage metal rectifiers.

horizontal levels as white objects, since it is here that the peak beam current has reduced the E.H.T. voltage, and thus increased the deflection sensitivity. No confusion need arise with the effect which is produced by poor separation of the synchronising signals or "pulling on whites," since this causes a whole strip of the picture to move bodily to the right, thus causing a hollow instead of a bulge at the left-hand side.

If the time constant is adequate, but the regulation is poor, the picture will change in size and in overall focus when the mean D.C. component of the picture changes. This effect is usually seen at its worst on film transmissions where the rapid cutting from one type of shot to another (including titles) causes frequent changes in the mean D.C. level. If this defect is suspected, the picture should be reduced in size slightly so that the edges are just visible inside the mask. If the picture is then carefully watched, and the regulation is in fact poor, it will be seen to alter in size and change slightly in focus at the moment of cutting from shot to shot. The effect can also be produced by varying either the brilliance or the contrast controls, since both of these alter the mean beam current. A simple way of demonstrating the change in mean beam current during a

transmission, particularly a film, is to turn one's back to the receiver, and observe the viewing room by the light from the screen alone. The total light in the room is proportional to the mean beam current, and the large light variation which will be observed should convince anyone of the need for a well-regulated E.H.T. supply.

New Metal Rectifiers.

In the following comparison between various possible forms of power supply, there is one important factor which affects nearly all of them. This is the recent introduction of a new range of metal rectifiers (type 36EHT) which operate at extremely high voltages per element. The increase which has been made in the operating voltage is so outstanding that it completely upsets the present balance of advantages between various methods of deriving E.H.T. Before reviewing these systems it is therefore essential to understand what these new rectifiers can do. The construction is tubular, as shown in the photograph; diameter is $\frac{7}{16}$ in, and connection is made by soldering directly to the end-tags. The smaller units (up to say 6000 volts peak inverse) can be mounted by soldering directly to tag boards or to other components, while

Television E.H.T. Supply—

the larger units require some additional support by lightly clamping with insulating material at a suitable point. 36EHT rectifiers are rated at 0.5 mA mean output, which meets all the requirements of domestic television receivers, and in fact almost all other C.R. equipment. The self-capacitance of these rectifiers is also low, so that they will perform excellently in line fly-back pulse circuits, and will rectify efficiently up to frequencies of the order of 50 kc/s.

Various E.H.T. systems, both conventional and new, will now be examined, and it will be seen to what extent it is practicable or economic to achieve the performance requirements of a good E.H.T. power pack which have been set out above.

E.H.T. Systems Compared.

Having now defined the essential performance points of a good E.H.T. supply, various systems can be compared, and the additional factors of cost, reliability, weight and chassis space can also be taken into account. We will consider: (a) High voltage mains transformer and rectifier; (b) High frequency oscillator and rectifier; (c) Rectification of the line fly-back pulses appearing at the line output transformer. A new method of deriving

E.H.T. from the normal H.T. transformer through the "Westekt" unit will be considered in a concluding article.

(a) *High-Voltage mains transformer and half-wave rectifier.*—Although the circuit appears simple on paper (Fig. 1), it is not actually so from the designer's viewpoint, as a difficult compromise between cost and reliability has to be made. It has sometimes been overlooked that in the circuit of Fig. 1 (a), with a 3500-volt R.M.S. secondary winding, a peak voltage of 10 kV appears between the valve heater winding and the end of the E.H.T. winding, and moreover,

that this voltage does not appear until the valve is plugged in. A case has recently been brought to the writer's notice in which a number of mains transformers, quite satisfactory on open-circuit test, all failed soon after being connected up with a valve in circuit.

If the circuit is re-arranged as in (b), with the heater winding joined directly to the lower end of the E.H.T. winding, the same 10-kV peak now appears between the windings and the transformer core, although the output is only 5 kV in each case. By the use of a metal rectifier as shown in (c), the difficulty is overcome with a very great increase in reliability; in fact, a transformer which has actually broken down between windings when used in the circuit of (a) may often be used with complete satisfaction when connected as in (c). A further advantage of (c) is that the safety discharge resistor of about 100 M Ω connected across the capacitor is

only permanent answer. This normally increases the weight and cost of a component already too heavy and expensive, and has tended to stimulate the search for alternative methods.

The regulation obtainable from all the circuits of Fig. 1 is, however excellent, and well within the limit of 10 per cent per 100 μ A specified above, but it must be remembered that some degree of smoothing is usually necessary unless C is made very large. This is usually provided by a smoothing resistor in the positive line, followed by a second high-voltage capacitor, and the voltage drop in this resistor will cause some deterioration in the regulation. However, a value of 1 megohm will only increase the regulation by 2 per cent, and the total can be easily permitted on directly viewed tubes, as it still will not exceed 10 per cent.

(b) *High Frequency Oscillator and Rectifier.* One method of dispensing with the high voltage mains transformer is to use an R.F. power oscillator¹, and then, in effect, to use an E.H.T. transformer working at a much higher frequency. This reduces the number of turns necessary on the transformer, and the iron required may also be greatly reduced, or even eliminated.

However, the transformer does not become particularly simple to design since the distributed capacitance and losses must be kept low, while the tendency to corona and surface tracking is greater than at low frequencies. If a mains transformer is used in the receiver, a highly insulated heater winding may be included on it to supply the valve rectifier or alternatively, a suitable rectifier valve may be heated with R.F. current derived from a low-voltage winding coupled to the oscillator coils. In this case, this heater winding must be insulated to withstand a peak of twice the output voltage, exactly as in the low frequency circuit of Fig. 1 (a) or (b). However, the problem is somewhat eased compared with the 50-cycle case, since at R.F. the spacing can be much greater, and air can be used as part of the insulation. A power

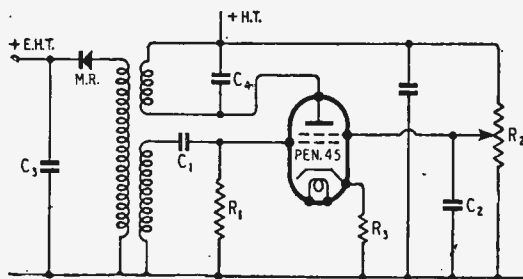

Fig. 2. Typical R.F. oscillator 5 kV E.H.T. unit using metal rectification. C_1 , 0.001 μ F; C_2 , 0.1 μ F; C_3 , 0.005 μ F; 6 kV (T.C.C. 'Cathodray'); C_4 (see text). R_1 , 1 M Ω ; R_2 , 100 k Ω ; R_3 , 50 Ω ; MR = Westinghouse 36EHT145. Operating frequency approx. 50 kc/s.

no longer required, since a discharge path of this order of resistance is provided through the metal rectifier and transformer.

Experience has shown that to obtain reliable service from small transformers wound for these voltages, particularly when using valve rectifiers, a change of technique is necessary. In order to prevent the intrusion of dirt and moisture which will eventually cause almost any small transformer to break down in circuits (a) or (b), it is now becoming accepted that the complete hermetic sealing of the transformer in a metal can filled with a good dielectric grease or wax is the

¹ "R-F H.T. Power Supplies for Cathode-Ray Tubes," by R. D. Boadle, *A.W.A. Technical Review*, 1946, Vol. 7, p. 53.

valve is necessary for the oscillator since the R.F. output has to be adequate to supply the valve

tuning condenser C_4 will naturally depend on frequency and transformer characteristics.

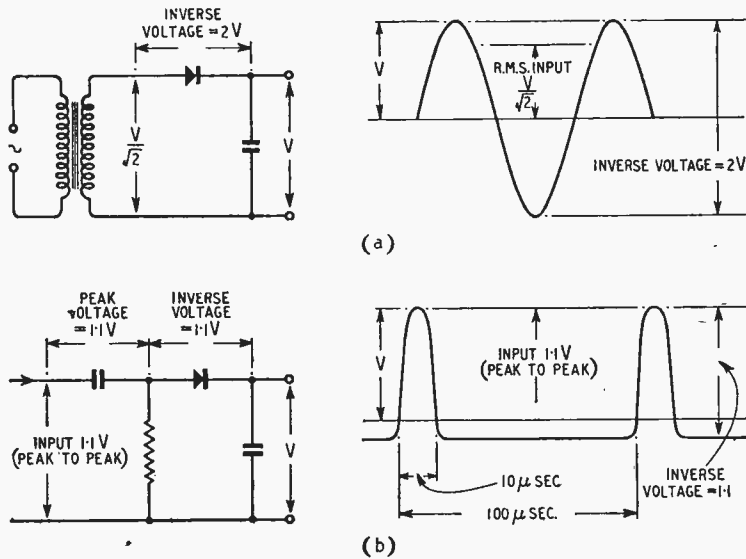

Fig. 3. Illustrating the reduction in rectifier inverse voltage brought about by a pulse waveform. Output voltage is V in both cases. (a) sine wave, rectifier inverse = $2V$; (b) pulse wave, rectifier inverse = $1.1V$. Feed condenser peak = $1.1V$.

rectifier heater as well as the useful rectified output, and apart from the cost of this extra valve, the additional drain on the H.T. supply and the additional heater load form a most unwelcome additional burden on the already hard-pressed mains transformer and rectifier. A triode valve will often provide better regulation, but a tetrode is usually employed on account of the higher overall efficiency which can be obtained. The efficiency can, however, be further increased and the transformer design simplified by the use of a 36EHT rectifier, provided that the operating frequency is kept below about 50kc/s, and this requirement supports other design factors which also tend towards keeping the frequency down for a better performance. A possible circuit is shown in Fig. 2. A Pen45 is used as a power oscillator, and is biased by grid current rectification over R_1 , added to cathode bias across R_3 . The E.H.T. output can be conveniently adjusted by the screen feed resistor R_2 , and the values given are suitable for a frequency of about 50kc/s. The E.H.T. winding should be carefully section-wound and well insulated, while the value of the

(c) *E.H.T. from Line Fly-Back Pulses.*—During the time of the line scan (when the spot is moving from left to right across the picture) the current is increased linearly in the deflection coils and line output transformer, and energy is being gradually stored in the increasing magnetic fields associated with both these components. At the end of the line scan the output pentode is driven

surge naturally depends on the maximum current value reached just before cut-off, the inductance, and the total losses in the whole circuit or, in other words, upon the Q of the output circuit. If no provision is made to absorb this energy, undesirable oscillations will result which will last beyond the fly-back period and will destroy the linearity of the next scanning line, and it is therefore normal practice to connect a series RC circuit across the transformer secondary for this purpose, several watts being dissipated by the resistor. With a normal transformer, however, a pulse of about 2,000V with a duration of about 8 or 10 μ sec still remains in spite of the additional damping, and this can be rectified and used to provide E.H.T. for the tube²

Apart from the agreeable fact that it is already available in the receiver, this pulse waveform is also desirable as it results in a great reduction in the rectifier inverse voltage as compared with a sinusoidal input waveform developing the same output voltage. The reason for this is demonstrated in Fig. 3, in which (a) represents a conventional half-wave rectifier operating on a sinusoidal input waveform. At the current loadings under consideration the D.C. voltage is very nearly equal to the peak of the input wave, but the peak inverse voltage which occurs on the following half-cycle is actually double the output voltage.

TABLE 1
Details of some typical 36EHT rectifiers.

Rectifier Type	Overall Length	Peak Inverse Voltage	D.C. Output Voltage	
			In Half-Wave Pulse Circuit (Single-stage)	In 50-cycle Half-Wave Circuit
36EHT20	1.41	1,600	1,300	700
36EHT40	2.23	3,200	2,620	1,400
36EHT70	3.67	5,600	4,580	2,330
36EHT130	6.33	10,400	8,500	4,330
36EHT160	7.78	12,800	10,400	5,230
36EHT240	11.26	19,200	15,700	8,400

rapidly beyond cut-off, and the collapse of these fields produces a high positive voltage surge at the anode. The magnitude of this

At (b) a half-wave rectifier is shown operating on a typical

² "Television E.H.T. Supply," by W. F. Cocking, *Wireless World*, June 1917, Vol. 53, p. 207.

Television E.H.T. Supply—
pulse waveform having a duration of about $10\mu\text{sec}$ in the total line scan time of $100\mu\text{sec}$. Since there is no direct-current component

half-cycle of the oscillation by a self-biased diode or metal rectifier. This arrangement is shown in Fig. 4, in which C_1 charges to a bias voltage which is adjustable

the high frequency (10 kc/s), and since Series 36EHT rectifiers are also so small, a very compact and light source of E.H.T. can be built; it is, moreover, free from the cost and breakdown difficulties of highly insulated heater windings. Since the pulse voltage multiplier circuit has to operate from a "one-sided" wave, it differs from a conventional multiplier circuit, and a typical arrangement is shown in Fig. 5. The positive-going anode pulse in effect charges up the capacitors C_2 in parallel through the rectifiers and the feed capacitors C_1 and C_3 . Capacitors C_2 then discharge in series through the load, and the cross-connected resistors R_1 . It is worth noting that if three or more stages are used, C_3 , and any following capacitors, may be fed directly from the valve anode instead of from the previous feed capacitor, as shown in Fig. 5. If this is done, the additional current and resultant voltage drop in C_1 is avoided, but C_3 must of course be increased in voltage rating to a figure of double the pulse voltage. This latter arrangement is known as "parallel feed," since all the rectifiers are fed from their own capacitors connected in parallel to the feed point (the valve anode in this case) while the arrangement of Fig. 5 is known as "series feed," as

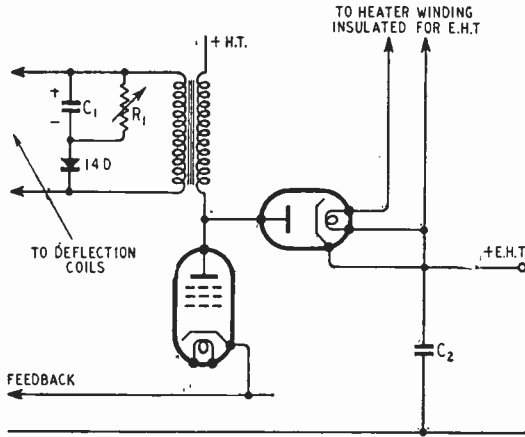

Fig. 4. Valve rectification of line fly-back pulse. The circuit is usually limited to a single half-wave rectifier, and the transformer must be designed to give a very high peak voltage. Oscillation is damped by a self-biased rectifier type 14D across the deflection coils, as an RC circuit would damp the desired peak. C_1 25 μF , 25 V; C_2 , 0.005 μF ; R_1 , 1000 Ω .

in the input wave, the areas on either side of the zero line must be equal, and therefore with the time proportions shown, the zero line sinks nearly to the bottom of the waveform and the reverse voltage, although lasting for about 90 per cent of the time, becomes only about 10 per cent greater than the output voltage. The long duration of the inverse voltage makes it essential to ensure that the rectifier reverse leakage is negligible at this voltage, whereas in (a), although the peak inverse voltage is much greater, the duration is shorter, so that a somewhat higher instantaneous reverse rectifier current can be allowed. This is the reason for the different inverse voltage ratings recommended for the new type 36EHT rectifiers when used in different circuits. (See Table 1).

Half-Wave Valve Rectifier.—When a valve is used to rectify the pulse, the circuit is limited in practice to a straight half-wave arrangement, both on economic grounds, and also as a result of heater difficulties, and it is therefore necessary to design the line output transformer with very low losses in order to develop a peak voltage higher than the desired E.H.T. voltage across the primary winding. In this case a conventional series RC damping circuit would also reduce the desired peak voltage, so that damping is usually provided by short-circuiting the first unwanted

by R_1 to vary the clipping level.

Pulse Voltage Multiplier.—By taking advantage of the new 36EHT series of metal rectifiers, a pulse-driven voltage multiplier may be used. There is no need to take any special steps to generate a very high-voltage pulse (itself a probable source of breakdown in the line output transformer) and the normal amplitude of pulse which is developed by a perfectly standard transformer, damped if required by the conventional RC

Fig. 5. Pulse-driven voltage multiplier circuit fed from a normal line output transformer. Heavy lines show a doubler, dotted lines show the additions to form a tripler. Normal RC damping across deflector coils may be used (dotted), or to increase the output voltage a self-biased metal rectifier may be substituted as shown. See Table 2 for component values for various output voltages.

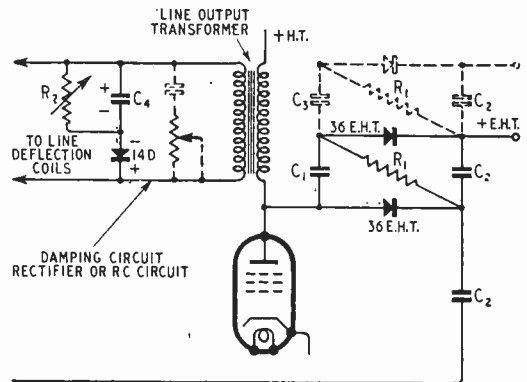

circuit, may be used and multiplied up to the extent required. The pulse voltage multiplier circuit may comprise any desired number of stages; i.e., doubler, tripler, quadrupler, etc. As only small capacitors are required owing to

although the rectifiers are all fed in parallel, the feed capacitors are series connected. In general, series feed is preferable as all the capacitors may be of the same voltage rating which is usually convenient.

The connecting leads should be kept as short as possible, to reduce the stray capacitance. As these

leads are almost all carrying very high-voltage pulses at line frequency, they can, if unduly long, easily inject line frequency pulses into the frame scan generator circuits and thus impair the inter-lace.

Since the discharge path lies through the series resistors R_1 , it is apparent that the regulation is bound to be impaired to some extent, but if R_1 is made too low,

possible without producing the effects of poor regulation which have already been described. Either RC damping or rectifier damping may be used, the latter producing a higher output voltage as already mentioned.

An approximate guide to the number of stages required, and the recommended components for various output voltages, is given in Table 2, but owing to variation

TABLE 2

Typical operating conditions for the pulse multiplier circuit of Fig. 5. Capacitors all 0.005 μ F. (May be reduced to 0.001 μ F for parallel feed). $R_1 = 1 M\Omega$, $R_2 = 1,000 \Omega$ variable.

Peak Pulse Input Voltage	Approximate D.C. Output Voltage at 100 μ A. Load			Rectifiers	
	Half-wave	Doubler	Tripler	E.H.T.	Damping (for 5 : 1 Transformer)
1,450	1,310	2,340	3,340	36EHT20	14D19
1,810	1,640	2,930	4,180	36EHT25	14D24
2,180	1,960	3,520	5,000	36EHT30	14D28
2,540	2,190	4,100	5,850	36EHT35	14D28
2,900	2,620	4,680	6,570	36EHT40	14D128
3,470	2,950	5,280	7,520	36EHT45	14D36

the output voltage will be reduced. The best compromise will depend on the mean beam current required, as well as other indeterminate variables, but a value of 1 megohm may be used for the first tests, as it will generally result in a voltage regulation of between 5 and 10 per cent per 100 μ A. In general, however, R_1 should be increased as much as

in pulse shape and duration produced by different designs of transformer and different degrees of negative feed-back, etc., it should not be expected that the output voltages listed will be exactly obtained in all cases, but the circuit is very flexible, and it is hoped that the information given will be of help to those wishing to try the circuit.

Short-wave Conditions

February in Retrospect : Forecast for April

By T. W. BENNINGTON and L. J. PRECHNER (Eng. Div., B.B.C.)

DURING February the average maximum usable frequencies for these latitudes increased somewhat both by day and night. The daytime increase—mentioned in this column for February—was due to normal seasonal trend after the "midwinter effect," and the night-time increase is the beginning of the increase towards the midsummer maximum.

The daytime increase was much less than expected, due possibly to decreasing sunspot activity. Although long-distance communication on the higher frequencies was good to most parts of the world, frequencies as high as 50 Mc/s were practically never usable, though they had been during November.

Night-time working frequencies, though relatively low, were mostly above 9 Mc/s, except over a few high-latitude paths.

Conditions were not severely disturbed at any time during the month although ionosphere storms did occur during the periods 2nd, 11th and 15th-18th.

Forecast

In April, while the daytime M.U.F.s in the Northern Hemisphere should begin to decrease towards the midsummer minimum, the night-time M.U.F.s should continue their increase towards the midsummer maximum. However, since daylight will last longer, moderately high frequencies can remain in use

for considerably longer periods. In April working frequencies for most transmission paths will be somewhat lower than in March during the full daylight period, somewhat higher during the morning and evening periods, and considerably higher during the full darkness period.

Daytime communication on high frequencies (like the 28-Mc/s band) though still possible should be rather less than in March. Over many circuits frequencies as high as 15 Mc/s—or even higher in some cases—should remain usable till well after midnight. Frequencies lower than 11 Mc/s will be seldom required at any time during the night.

For transmission distances between about 600 and 1,000 miles the E layer may often control transmission during the daytime, and higher working frequencies may be needed than would otherwise have been the case.

Sporadic E, though it should begin to increase, is not likely to be very prevalent during the month, the real increase usually occurring in May.

Below are given, in terms of the broadcast bands, the working frequencies which should be regularly usable during April for four long-distance circuits running in different directions from this country. All times mentioned here are in G.M.T. In addition, a figure in brackets is given for the use of those whose primary interest is the exploitation of certain frequency bands, and this indicates the highest frequency likely to be usable for about 25 per cent of the time during the month for communication by way of the regular layers:—

Montreal :	0000	15 Mc/s	(22 Mc/s)
	0100	11 "	(18 ")
	0900	15 "	(22 ")
	1000	17 "	(28 ")
	1200	21 "	(32 ")
	2100	17 "	(28 ")
	2300	15 "	(20 ")
Buenos Aires:	0000	17 Mc/s	(25 Mc/s)
	0200	15 "	(21 ")
	0900	21 "	(30 ")
	1000	26 "	(39 ")
	2100	21 "	(32 ")
	2300	17 "	(23 ")
Cape Town :	0000	17 Mc/s	(25 Mc/s)
	0600	21 "	(29 ")
	0700	26 "	(40 ")
	2000	21 "	(30 ")
	2300	17 "	(24 ")
Chungking :	0000	11 Mc/s	(16 Mc/s)
	0300	15 "	(21 ")
	0400	17 "	(25 ")
	0600	21 "	(30 ")
	1600	17 "	(24 ")
	2000	15 "	(22 ")
	2200	11 "	(17 ")

A moderate amount of ionosphere storminess is usual during April. At the time of writing it would appear that ionosphere storms are more likely to occur during the periods 1st, 8th, 10th-13th, 25th-26th and 28th, than on the other days of the month.

Push-Pull Input Circuits

Part 4.—The Anode Follower

By W. T. COCKING, M.I.E.E.

AN important and widely used type of phase-reverser must now be considered. Originally known as the paraphase¹ amplifier, it was later termed the see-saw² circuit and in essentials it is identical with a radar circuit commonly called an anode follower.³ Basically, it is a circuit, not unlike those described in Part 3, in which a phase-reversing amplifier is fed from a potential divider so that the overall amplification is unity. The amplifier, however, is provided with negative feedback of a form giving a low input impedance to the valve and the input impedance forms one arm of the input potential divider. As the input impedance depends on the amplification and the potential-divider ratio depends on the input impedance the circuit is largely self-compensating for changes of amplification. Discussion of the circuit is complicated by the fact that there are several minor variations of it, variations chiefly in the positions of blocking capacitors, but which do influence

Fig. 18. One form of anode-follower phase-reverser is shown here in its essentials. R_i is the grid leak of the following valve.

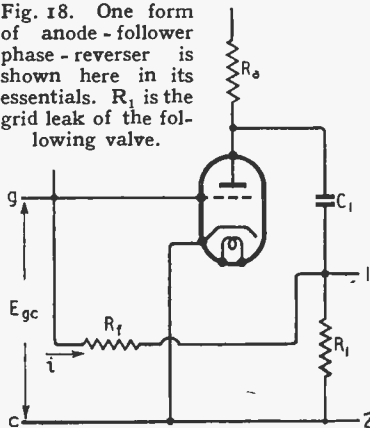

the performance at low frequencies. In their performance at medium and high frequencies the circuits are all substantially the same.

One arrangement of the ampli-

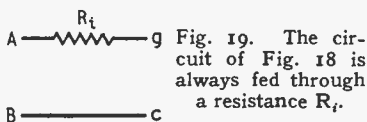

Fig. 19. The circuit of Fig. 18 is always fed through a resistance R_i .

fier part is shown in Fig. 18; no bias circuit is shown since it is assumed that the arrangements made for it have no effect on the operation. Considering matters at middle frequencies where both C_1 and any shunt capacitance can be ignored, the amplification is $A_0 = -E_{12}/E_{gc}$. The voltage E_{gc} drives a current i through R_f and as the grid of the valve is assumed to take no current, the input impedance is, by definition, $Z_{in} = E_{gc}/i$.

By inspection of Fig. 18 it is clear that $E_{gc} - E_{12} = iR_f$, consequently $Z_{in} = R_f/(1 + A_0)$. Now if this circuit is fed from a voltage E_{AB} through a series resistance R_i as in Fig. 19, $E_{gc} = E_{AB}/(1 + R_i/Z_{in})$ and hence the overall amplification $-E_{12}/E_{AB} = A = A_0 / [1 + \frac{R_i}{R_f}(1 + A_0)]$.

For push-pull operation it is required that $A = 1$, therefore, the balance condition is

$$\frac{R_i}{R_f} = \frac{A_0 - 1}{A_0 + 1}$$

In some variations of the circuit a grid leak is connected across terminals g, c . Its effect can be taken into account by considering it as a resistance in shunt with Z_{in} .

From the above expression it is clear that if A_0 is large compared with unity R_i and R_f are nearly equal in value and then $A = A_0/(A_0 + 2)$. It is also plain to see that if A_0 is large compared with 2, A is very nearly 1 and is almost independent of the actual value of A_0 . In other words, a

circuit variation which acts to alter A_0 changes the input impedance Z_{in} , and so alters the input potential-divider ratio that it compensates for the change of A_0 .

The value of A_0 is easily calculable and is given by Eqn. (2) of Appendix IV. It is convenient to express the amplification and the balance condition in terms of $g_m Z$ and Z/Z_f rather than A_0 and this is done in Eqns. (4) and (5). It then becomes clear that if it is desired to have R_i and R_f of equal value it is necessary to have $g_m R$ very large compared with unity. With a triode valve R can rarely be much greater than

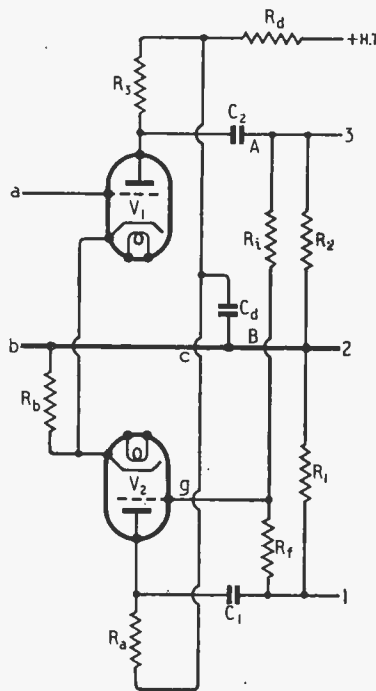

Fig. 20. The phase-reverser of Figs. 18 and 19 is drawn here combined in the usual manner with the preceding stage.

10 - 15 kΩ and g_m is usually about 2 mA/V so that $g_m R$ is of the order of 20 - 30. While this is certainly a good deal larger than unity it is not very large compared with it, and with a triode it is usually necessary to adjust R_i or R_f for balance.

With a pentode R can often be

¹ "Science Museum Receiver," by R. F. G. Denman and A. S. Brereton. *Wireless World*, July 30th and August 6th, 1930. Vol. 27, pp. 96 and 116.

² "The See-Saw Circuit," by M. G. Scroggie. *Wireless World*, June 1945. Vol. 51, p. 194. See also p. 263, September 1945.

³ "Introduction to Circuit Techniques for Radiolocation," by F. C. Williams. *Journ. Instn. Elect. Engrs.* Vol. 93, Part IIIA, No. 1, p. 280.

20 - 50 kΩ and g_m can be 2 - 6 mA/V, so that $g_m R$ may be 40 - 300. With values of over 200, say, R_i and R_f can be equal

$1 + g_m R$ will rarely be less than 20. We need only consider Eqn. (13) in practice, therefore.

In a typical case with a triode

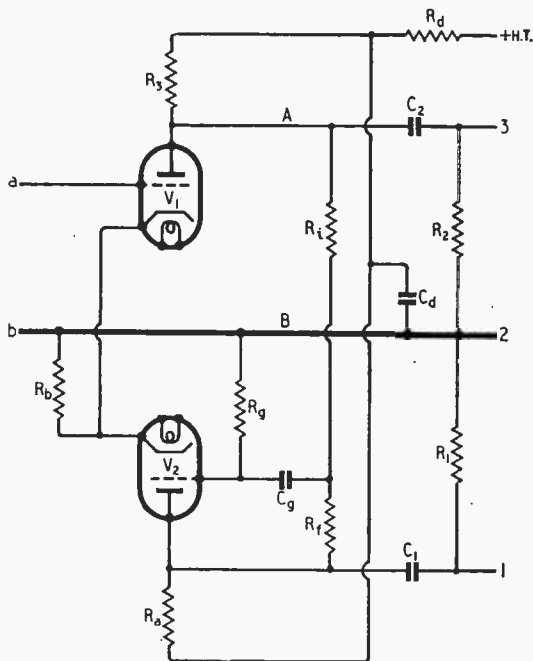

Fig. 21. A modified circuit is shown here in which R_i and R_f are transferred to the input side of C_1 and C_2 .

we might have $g_m = 2$ mA/V, $R = 10$ kΩ, $R_f = 100$ kΩ, $C = 100$ pF, $f = 10$ kc/s. Then $U_2 = 0.006$; the unbalance at 10,000 c/s is only 0.6 per cent, which is negligible. With a pentode $g_m R$ tends to be higher and U_2 approximates $2\omega C/g_m$. It is clear, therefore, that the unbalance at high audio frequencies is sufficiently small for all ordinary requirements.

It is to be noted that the equations have been developed

on the assumption that $C_f R_f = C_i R_i$. As R_f and R_i are nearly equal this means that R_i should be shunted by a capacitance equal to the grid-anode capacitance of the valve. The low capacitance of a screened pentode is an advantage in making any such shunt to R_i unnecessary.

At low frequencies the coupling capacitor C_1 becomes important. The grid of one push-pull valve is connected to 1 of Fig. 18 and the grid of the other to A of Fig. 19. The necessary equations are developed in the Appendix and

Fig. 22. A further modification of the circuit consists of the omission of C_g and the inclusion of C_i and C_f .

Eqn. (17) gives the out-of-phase unbalance approximately, the in-phase unbalance being negligible.

With a triode we might well have $g_m = 2$ mA/V, $r_a = 15$ kΩ, $R_a = 45$ kΩ, $R_1 = 250$ kΩ, $R_f = 250$ kΩ, $C_1 = 0.1$ μF. These give

$R'' = 11.25$ kΩ, $R = 10.8$ kΩ, $R' = 261.25$ kΩ, and so at 50 c/s, $U_2 = 0.01$. As under the conditions given the value of R_f does not affect the high-frequency response, the change of value between the two examples is unimportant. At low frequencies a high value of R_f is advantageous; thus, if in the last example R_f is reduced to 100 kΩ, U_2 is increased to 0.018.

This is, of course, as one would expect, for R_1 and R_f are almost in parallel as regards the feed through C_1 . As regards the high-frequency response it must not be forgotten that it is independent of R_f only if R_i and R_f are shunted by equal capacitances. If they are not, then the high-frequency unbalance will increase with high values of R_f .

It is to be noted that the low-frequency unbalance arises because there is one more coupling on one side of the chain than on the other. In Fig. 19 one push-pull valve is fed directly from A, B, but the other is fed from 1, 2 of Fig. 18 and this voltage is derived from A, B, through the whole network including $C_1 R_1$.

The time constant effective is not that of $C_1 R_1$ alone, however,

with only a very small error. From this point of view, therefore, the pentode is superior to the triode.

Technically, of course, there is no particular merit in having R_i and R_f equal. In practice, however, if they can be equal a balance adjustment is avoided, for it is not difficult to pick two resistors for equality of resistance when their precise actual values are unimportant.

We can now consider the performance at high frequencies. R_a is in effect shunted by a capacitance C comprising the anode-cathode capacitance of the valve, stray circuit capacitance and the input capacitance of the following stage. Also R_f is shunted by the grid-anode capacitance of the valve. This is appreciable with the triode, but negligible with the screened pentode.

The relevant equations are developed in Appendix IV and it is sufficient to use the approximate relations (12) and (13). It is easy to see that if the out-of-phase component of output is satisfactorily low the in-phase unbalance is negligible since

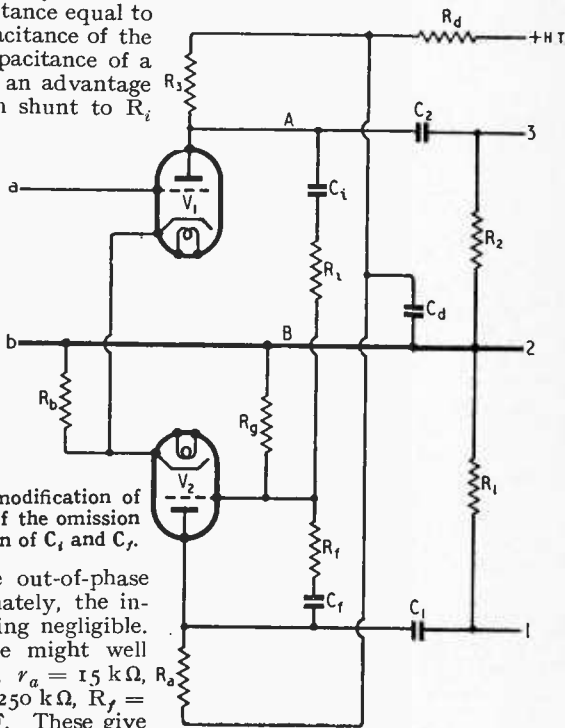

Push-pull Input Circuits—

as in the case of the non-feedback circuits of Part III, for the effective value is greatly increased by the feedback. This is clearly shown by the approximate relation of Eqn. (17a) which holds when $g_m R$ is very large. The time constant is $C_1 R'$ ($\approx C_1 R_1$) multiplied by $g_m R / (1 + R_1/R_f)$.

The complete circuit of the phase-reverser with the preceding amplifier is drawn in its usual form in Fig. 20 and the parts belonging to the phase-reverser are lettered in the same way as in Figs. 18 and 19. If V_1 and V_2 are similar valves and if $R_3 = R_a$, $R_2 = R_1$, and $C_2 = C_1$ the alternating anode currents of the two valves will be nearly equal and opposite. The bias resistor R_b and the decoupling components R_d and C_d will then have a negligible effect on the performance. This is actually the only reason for using similar valves and circuit values, for there is no push-pull action as regards distortion.

Because of the negative feedback provided on V_2 by R_f this stage is much more linear than V_1 , so that if the two stages are otherwise similar it is necessary to design V_1 for the requisite undistorted output and one can be assured that V_2 will be rather better.

Suitable values for the circuit of Fig. 20 using EF37 valves as triodes are:— $R_a = R_3 = 47 \text{ k}\Omega$, $R_1 = R_2 = 220 \text{ k}\Omega$, $R_b = 750 \Omega$, $R_f = 250 \text{ k}\Omega$, $R_i = 226 \text{ k}\Omega$, $C_1 = C_2 = 0.1 \mu\text{F}$. The output obtainable is at each pair of output terminals 3, 2 and 1, 2, and is the output of which V_1 alone is capable with the H.T. supply available and the value of the decoupling resistor R_d .

A variation of the circuit of Fig. 20 is produced by omitting R_1 and R_2 and connecting a resistor to earth from the junction of R_i and R_f ; that is, from the grid of V_2 . This change in itself affects the performance very little and it gives a saving of one resistor. However, it is desirable for this added resistor to be large compared with Z_{in} , which means that it cannot be much different from R_f . It is common to the grid circuits of three valves and so should not be very large. As V_2 is not a large valve it is not

APPENDIX IV.

Referring to Fig. 18, let $A_0 = E_{21}/E_{gc}$ and $Z_{in} = E_{gc}/i$. Now $iZ_f = E_{gc} + E_{21}$, therefore,

$$Z_{in} = \frac{Z_f}{1 + A_0} \dots \dots \dots (1)$$

Also, at frequencies for which the reactance of C_1 can be ignored,

$$i_a = g_m E_{gc}$$

$$E_{21} = (i_a - i) Z$$

Therefore, $A_0 = \frac{g_m Z - Z/Z_f}{1 + Z/Z_f} \dots \dots \dots (2)$

When the stage is fed through an impedance Z_i , Fig. 19,

$$\frac{E_{21}}{E_{AB}} = A = \frac{A_0}{1 + Z_i/Z_{in}} \dots \dots \dots (3)$$

$$= \frac{A_0}{1 + \frac{Z_i}{Z_f}(1 + A_0)} = \frac{g_m Z_i - Z_i/Z_f}{1 + Z_i/Z_f + (1 + g_m Z) Z_i/Z_f} \dots (4)$$

At middle frequencies all reactances are negligible and all the Z terms become R terms. The condition for balance in push-pull operation is $A = 1$, hence

$$\frac{R_f}{R_f} = 1 - 2 \frac{1 + R/R_f}{1 + g_m R} \dots \dots \dots (5)$$

At high frequencies $Z = R/(1 + j\omega CR)$, $Z_f = R_f/(1 + j\omega C_f R_f)$, $Z_i = R_i/(1 + j\omega C_i R_i)$ and then

$$A = \frac{g_m R - R/R_f - j\omega C_f R}{\left\{1 + \frac{R}{R_f} + \frac{R_i}{R_f}(1 + g_m R) \frac{1 + j\omega C_f R_f}{1 + j\omega C_i R_i}\right\} + j\omega CR \left\{1 + \frac{C_f}{C} + \frac{R_i}{R_f} \frac{1 + j\omega C_f R_f}{1 + j\omega C_i R_i}\right\}}$$

When $C_f R_f = C_i R_i$ this reduces to

$$A = \frac{g_m R - R/R_f - j\omega C_f R}{1 + \frac{R}{R_f} + \frac{R_i}{R_f}(1 + g_m R) + j\omega CR \left\{1 + \frac{C_f}{C} + \frac{R_i}{R_f}\right\}} \dots (7)$$

Inserting the value of R_i/R_f given by Eqn. (5) gives

$$A = \frac{g_m R - R/R_f - j\omega C_f R}{g_m R - R/R_f + j\omega CR \left\{1 + \frac{C_f}{C} + \frac{g_m R - 1 - 2R/R_f}{g_m R + 1}\right\}}$$

The unbalance is

$$U = 1 - A$$

$$= \frac{j\omega CR \left\{1 + \frac{g_m R - 1 - 2R/R_f}{g_m R + 1}\right\}}{g_m R - \frac{R}{R_f} + j\omega CR \left\{1 + \frac{C_f}{C} + \frac{g_m R - 1 - 2R/R_f}{g_m R + 1}\right\}} \dots (9)$$

$$= U_1 + jU_2$$

$$U_1 = \frac{\omega CR \left\{\frac{C_f}{C} + 2 \frac{g_m R - R/R_f}{g_m R + 1}\right\}}{\left(g_m R - \frac{R}{R_f}\right)^2 + \omega^2 C^2 R^2 \left(\frac{C_f}{C} + 2 \frac{g_m R - R/R_f}{g_m R + 1}\right)^2} \dots (10)$$

$$= \frac{2\omega CR \left(g_m R - \frac{R}{R_f}\right)^2}{g_m R + 1} \dots (11)$$

$$U_2 = \frac{\left(g_m R - \frac{R}{R_f}\right)^2 + \omega^2 C^2 R^2 \left(\frac{C_f}{C} + 2 \frac{g_m R - R/R_f}{g_m R + 1}\right)^2}{g_m R + 1} \dots (11)$$

When U_1 and U_2 are small and $C_f \ll C$

$$U_1 \approx U_2 / (g_m R - R/R_f) \dots \dots \dots (12)$$

$$U_2 \approx \frac{2\omega CR}{g_m R + 1} \dots \dots \dots (13)$$

where $\frac{1}{R} = \frac{1}{r_a} + \frac{1}{R_a} + \frac{1}{R_1}$

At low frequencies the effect of the shunt capacitances is negligible, but C_1 is important. Equations (1) and (3) are still valid but the expression for A_0 is changed. If,

$$R'' = \frac{r_a R_a}{r_a + R_a}; R' = R_1 + R''$$

$$A_0 = \frac{E_{21}}{E_{gc}} = - \frac{\frac{R}{R_f} - g_m R + \frac{R/R_f}{j\omega C_1 R''}}{1 + \frac{R}{R_f} + \left(1 + \frac{R R'}{R_1 R''}\right) / j\omega C_1 R'} \dots \dots \dots (14)$$

Progress in Components

Review of the R.C.M.F. Exhibition

THE annual private exhibition organized by the Radio Component Manufacturers' Federation was held this year from March 2-4. In the following pages we give a broad survey of the industry's productions in the main categories, together with a list of makers. A general list of exhibitors, with addresses, appears at the end of the review.

CAPACITORS

Fixed Capacitors.—One interesting feature of the capacitor display is the greater interest shown by manufacturers in the silvered mica and silvered ceramic forms of construction.

Further headway has been made in the development of ceramic capacitors for television and V.H.F. equipment. Physical size is generally vitally important in order to keep lead lengths short and this is being greatly helped by the more general use of ceramics with very high dielectric constants. It gives about a tenfold increase in capacitance for a given size of component.

Standard Telephones had an entirely new range of silvered mica types for working voltages of 350 and 750 D.C. and in capacitances of from 10 to 3,000 pF.

The introduction of two new sizes of moulding for both their silvered and stacked mica series by Dubilier will, it is claimed, simplify the choice of a capacitor and lead to a marked reduction in the different varieties hitherto produced.

The smallest of the new range is the type S635 and is quite a miniature. It is made in capacitances of from 5 pF to 1,500 pF in preferred values. The other model, the S672, is a larger moulding and is used for capacitances of from about 1,800 pF to 10,000 pF.

T.C.C. make this type of capacitor in moulded cases as well as wax protected and among other firms adopting this form of construction are British N.S.F., Hunt, Stability Radio and United Insulators. The last mentioned had a twin silver mica capacitor made in the form of an I.F. end plate with four eyeletted holes in the corners for soldering lead-through wires. A large and a miniature size is available from 40 to 250 pF.

Erie make use of a ceramic mate-

rial called "Hi K" for some of their latest "Feed Thru" capacitors and so obtain capacitances up to 1,500 pF without increase in bulk.

Erie also had a new model described as the Post Ceramicon its main feature being that one connection is an internally screwed fixing bush and the other a lateral lead wire from the "live" element. It is intended to be mounted close to the valve-holders and provides a very short lead for cathode and screen by-passing. Two sizes are made, one up to 2,500 pF and the other up to 5,000 pF.

United Insulators had a new pattern lead-through insulator made also in normal and in high "K" ceramic. By the use of the latter its maximum capacitance is raised from 300 pF to 2,000 pF.

Other types of V.H.F. ceramic capacitors were a new button silvered mica model made by Erie for soldering to the chassis and the T.C.C. range of Micadisc capacitors for both receiving and transmitting apparatus. Dubilier had a lead-through bushing type among their long range of ceramic capacitors.

Electrolytics were shown in a profusion of capacitances, sizes and shapes and for every conceivable application. Special transmitting capacitors for which the ceramic "pot" form of construction is now largely favoured were seen among the exhibits of Dubilier, T.C.C., United Insulators, and Wego.

Variable Capacitors.—A new design gang condenser was shown by Plessey in which a tiny bandspread unit is embodied in each section. The rotor vanes are carried by the main shaft but stators are separately insulated. There are two- and three-gang types with either 10 pF or 60 pF bandspread sections and giving capacitance swings of 483 and 438 respectively.

Another Plessey innovation is the fitting of transparent dust covers

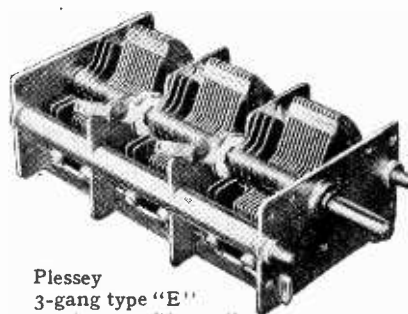

Plessey 3-gang type "E" condenser with small bandspread units in each section.

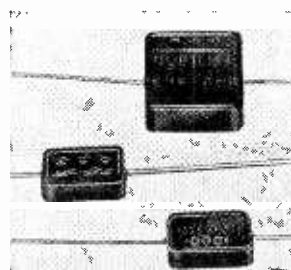

Examples of the new moulded cases now used by Dubilier for their silvered mica and stacked mica capacitors.

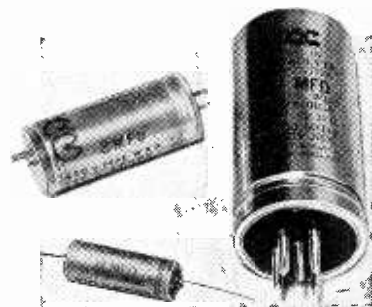

Three of the latest T.C.C. electrolytic capacitors; a 32 μ F plug-in model, an 8 μ F Micropack and the 30 μ F 15-volt Microtube.

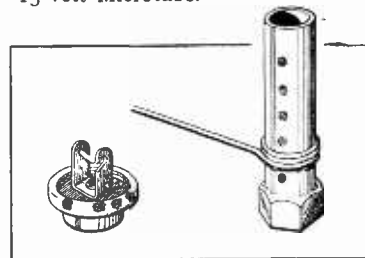

Two examples of the latest V.H.F. by-pass capacitors made by Erie.

Progress in Components—

to their miniature "R" type. Gang condensers with bandspread section of from 10 to 55pF were shown by Wingrove and Rogers (Polar), which firm also had some two-gang models with double spacing for the oscillator section as a means of combating condenser microphony.

Jackson Bros. have evolved a novel bandspread drive mechanism for ordinary gang condensers. It has dual pointers, coarse and fine slow-motion drives and separate but concentric spindles. The two ratios are 6 to 1 and 48 to 1 respectively. This provides a mechanical means of bandspread using standard variable capacitors. Short-wave capacitors, air and mica dielectric trimmers were also shown.

Precision type variable capacitors and many special types for high- and low-power transmitting and industrial heating apparatus were seen among the Cyldon exhibits. Square law, logarithmic law, linear frequency and capacitance are now available in most ranges. Rigid aluminium or brass frames are used with aluminium vanes and ceramic insulation.

A range of split stator transmitting capacitors for amateurs was shown by Labgear, a particularly well-made postage stamp type mica trimmer by Walter Instruments and air dielectric concentric trimmers by Mullard in sizes of 2 to 8pF and 3 to 30pF.

Makers: Bird (FA, T, TX, V), British Electrolytic (E), B.I. Callenders (E, P), British N.S.F. (P, M), Bulgín (FA, T), Daly (E), Dubilier (C, E, M, P, T, TX), Erie (C, T), Ferranti (E, P), Fulham (C), Hunt (C, E, M, P, TX), Jackson (T, TX, V), Labgear (TX), London Electrical Manufacturing (C, M), Mullard (T), Plessey (T, V), Stability Radio (M), Standard Telephones (M, P), Static Condenser (P, TX), Telegraph Condenser Co. (C, E, M, P, T, TX), Telephone Manufacturing Co. (M, P), United Insulation (C, M, TX), Walter Instruments (T), Wego (C, M, TX), Welwyn (T), Wingrove & Rogers (V, T).

***Abbreviations:** C, ceramic; E, electrolytic; FA, fixed air dielectric; M, mica; P, paper; T, trimmers and preset; TX, transmitting types; V, air dielectric variables.

RESISTORS

Fixed Resistors.—A considerable amount of research appears to have been devoted to the vitreous enamelled type of resistor mainly with the view to increasing the permissible loading with the sizes now in common use.

Painton has a new range which makes use of a ceramic tube of very

high thermal conductivity and which is designed to allow for forced draft or even liquid cooling to be used. It is said that the surface of the enamel remains perfectly homogenous under the most exacting tropical conditions and does not develop fine hair-line cracks known as "crasing" which give a foothold for corrosion and fungoid growths.

Resistance values are normally available up to 100kΩ in sizes ranging from 2in to 9½in long. A 4-in size is claimed to dissipate 1¼kw without damage.

This pattern is also available with a low inductive winding and one use of this type is as the R.F. load for a transmitter. The limiting frequency is above 20Mc/s.

A new style resistor shown by British Electric Resistance (Berco) consisted of a crimped strip wound edgewise on a porcelain tube and secured by vitreous enamel. So far only low values are available but the method almost doubles the power rating for a given size.

Many examples of power-type wire-wound resistors, some lac-

have placed it on a more general-purpose footing. High stability qualities are imparted by the method of manufacture, which basically consists of depositing a film of the finest possible carbon particles on an insulated rod, usually ceramic, although quartz fibre has been used by Welwyn for some special types.

This firm makes the high stability resistor in sizes ranging from ½ watt to 2 watts and up to 100MΩ. The standard finish is tropical-grade.

Dubilier recently added a ½ watt size to their high stability range which are available with either a varnish finish or insulated. They are made in preferred values up to 5.1MΩ.

There are four sizes in the Mullard series, ¼, ½, 1 and 2 watts respectively and resistance values up to 10MΩ are available.

A comprehensive range of carbon type resistors was shown by both Erie and Morgan. The smallest now made by Erie is a ¼ watt. Resistors of quite low value are now readily obtainable in this style.

Variable Resistors.—Whilst minor improvements have been made in the design of volume control potentiometers there are no major changes to be seen in this year's display. Linear, logarithmic and semi-logarithmic types were shown in the standard size, approximately 1½in in diameter, and in miniature patterns.

The latter varied considerably in size, one of the smallest being the Morganite type BJ measuring just under ¾in yet dissipating 0.1 watt. This pattern has the contacts placed on the back plate, which feature is embodied in several other Morganite models.

Bulgín make a range of wire-wound potentiometers with resistance values from 10Ω to 68kΩ in preferred values and of 3 watts rating. Among the other firms showing this type of component may be mentioned Dubilier, Erie, Goldsman and Plessey.

Colvern were showing a selection of wire-wound types in small sizes with and without switches and up to 100kΩ in value. These include single and two ganged models with separate concentric spindles or a common one. This firm also make a range of cam-corrected potentiometers for precision apparatus.

Ganged volume controls were shown also by Morgan Crucible, and

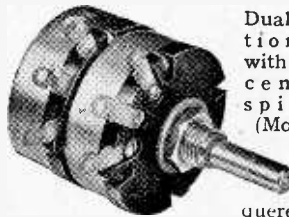

Dual potentiometer with concentric spindles (Morgan).

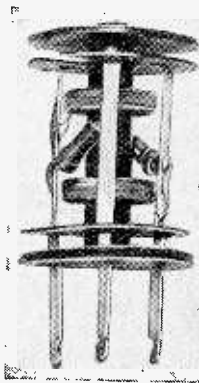

Interior of the Wright & Weaire miniature "round-can" I.F. transformer.

as dropping resistors in A.C./D.C. sets, and they are fitted with suitably positioned tappings.

There are a number of circuit positions in quite ordinary apparatus where a resistor of high stability is very desirable. Hitherto this pattern has been regarded as rather specialized, but recent developments

quered and some vitreous enamelled, were shown by Bulgín, Erg, Goldsman and Welwyn. This style is used to a large extent

other examples of ganged units were included among the exhibits of Berco and Painton.

Berco variable potentiometers are all wire-wound and range in value from a single-turn slide wire of a fraction of an ohm to one of 300 watts rating. This firm now applies the vitreous technique to the construction of potentiometers thereby doubling the wattage rating.

Painton variable resistors are essentially of a precision character and consist largely of faders and attenuator controls for use in broadcast monitoring and high-grade public address equipment. An R.F. attenuator was shown also by Advance Components.

Makers*: Advance (A), Belling & Lee (S), British Electrical Resistance (P, R, V, W), British N.S.F. (P), Bulgin (P, W), Colvern (R, P), Dubilier (HS, S, V, W), Erg (V, W), Eric (C, P, S), Goldsman (P, S, W), Morgan (C, P, S), Mullard (HS), Oliver Pell (R, W), Painton (A, P, V, W), Plessey (P), Welwyn (HS, V, W).

*Abbreviations: A, attenuators; C, composition; HS, high stability; P, potentiometer; R, rheostats; S, suppressors; V, vitreous enamelled; W, wire-wound.

COILS AND TRANSFORMERS

R.F. Coils.—Signal and oscillator-frequency coils fall into two categories—air-core and dust-iron core—which are about equal in numbers. The air-core types are usually wound on formers of about $\frac{1}{2}$ -in diameter and $1\frac{1}{2}$ -in length and are available with inductance values suitable for frequencies ranging from 30 Mc/s to 150 kc/s with the usual values of tuning capacitance. The iron-core types are smaller and in many cases the adjustable cores permit the exact matching of coils during the trimming of the set and so allow more accurate ganging to be achieved. Not all cores are adjustable, however, for in some types the cores are used as a factory adjustment for matching coils and are then sealed in position.

In addition to separate coils, quite a number of tuning units are made. These usually include the aerial and oscillator coils for three wavebands with switch and trimmers, and both Weymouth and Wearite have examples. Weymouth also showed a permeability tuner in which four dust-iron cores are attached to a plate and move together under the control of a cam.

Makers: Advance Components, Automatic Coil Winder, Labgear, Plessey, Radio Instruments, Weymouth, Wright & Weaire.

I.F. Transformers.—The inter-

mediate frequency of broadcast receivers is now virtually standardized at 465 kc/s, or very close there-

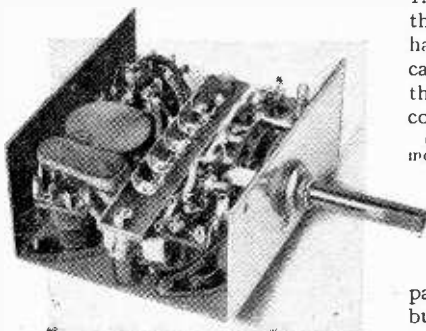

Weymouth type B.6 midget coil pack covering three wavebands.

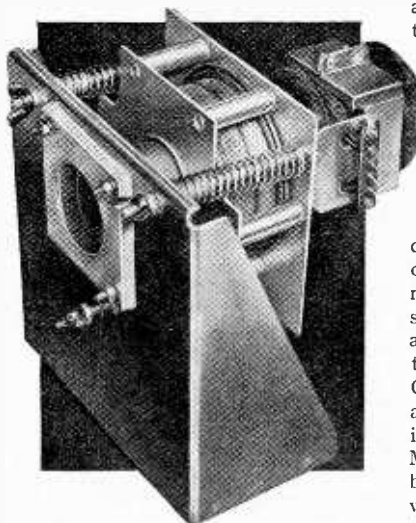

Plessey television focus and deflector coils.

to. A typical transformer consists of a pair of wave-wound coils tuned by fixed ceramic capacitors and with adjustable dust-iron cores for trimming. The spacing between the coils is fixed and arranged in manufacture so that the coupling, which is mainly by mutual inductance, is at about the optimum value. Overcoupling is rarely adopted in view of the trimming difficulties which arise. In some designs there are two types, one for use between amplifier stages and one for coupling an amplifier to a diode detector. The latter has rather tighter coupling because of the damping imposed by the detector.

In addition to the so-called standard-size components (about $1\frac{1}{2}$ -in square by $2\frac{1}{2}$ -in high) there are many miniature types which have

remarkably good characteristics. The Plessey M1, for instance, has a rectangular can measuring $\frac{1}{2}$ in by 1.79-in high. It is for 465 kc/s and the coils have a Q of 80. Wearite have a model with a 1-in circular can which is $1\frac{1}{2}$ -in high and again the Q is 80. In both cases dust-iron cores are used for trimming.

Makers: Bulgin, Labgear, Plessey, Weymouth, Wright & Weaire.

Mains and A.F. Transformers.—Most of the small mains and speaker transformers, typical of broadcast receiver practice are of the paper-interleaved type, and in all but the cheapest models the windings are impregnated. The standard primaries of the mains type are tapped for 200-250 V and sometimes a voltage-adjustment panel is fitted to the transformer. In the Plessey

types, for instance, both the solder tags and the snap-type connectors of the voltage adjuster are carried by a thin strip of insulation wrapped around the winding.

Some models, especially those for tropical use, are completely sealed. One example of this technique is the Parmeko "Mercury" model; it is sealed in a cylindrical copper can and designed to work in ambient temperatures from -40° to $+100^{\circ}$ C; it will also operate at an altitude up to 50,000 ft, so that it is suitable for aircraft use. Miniature sealed types were shown by Ferranti, who also had their well-known "A.F." series on view. Auto-transformers in sizes from 60 W to 250 kVA are made by Woden and, among a wide range of mains and A.F. transformers made by Partridge there is a modulation transformer rated at 45 W. It is tropicalized and has tapped primary ($3/10$ k Ω) and secondary ($6/12$ k Ω). This firm also showed a supersonic power transformer (300 W 50 kc/s).

Makers: Acoustic Products, Advance, Associated Electronic Engr., Automatic Coil Winder, Bulgin, British Communications, British Electric Resistance, Electro Acoustic, Ferranti, Labgear, Oliver Pell, Parmeko, Partridge Transformers, Plessey, Radio Instruments, Tannoy Products, Teledictor, Weymouth, Woden, Wright & Weaire, and most loud-speaker manufacturers.

Television Coils.—Deflector coils, focus coils, line and frame scan transformers and blocking oscillator coils appeared on the Plessey stand. The line-scan transformer is impregnated and contained in a cylindrical can packed with sponge rubber to reduce mechanical noise.

Progress in Components—

Coil Winders.—Machines for coil winding were shown by several firms and range from small hand-operated types to power-driven models for factory production. Among the latter, the Automatic Coil Winder "Macadie" is interesting for it is equipped with an automatic paper inserter.

Labgear were showing a hand-operated wave-winding machine of simple construction and capable of dealing with coils of up to 2½-in outside diameter. The traverse is operated by an adjustable friction-driven cam. Another wave-winder of the hand-operated type is the Neville's Winnipeg model.

Makers: Automatic Coil Winder, Labgear, Neville's.

CHASSIS FITTINGS

It is difficult in the space available to do justice to the wide variety of valve holders, group terminal boards, switches, etc., which the British component manufacturers have to offer. Selecting from some of the more recently introduced products we may mention the B8A and B8G holders shown by the Carr Fastener Co., and British Mechanical Productions, the Jones type inter-chassis connectors made by Belling and

"Macadie" automatic coil winder made by Automatic Coil Winder and Electrical Equipment.

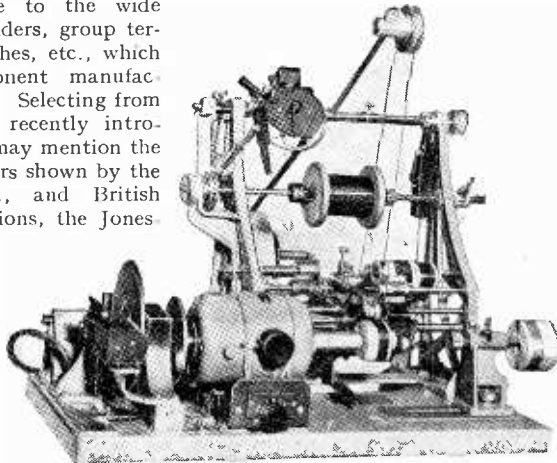

Lee, a new push-button unit by A.B. Metal Products, the universal dial drive unit shown by Plessey and a range of Bulgin's jack switches suitable for bias checking, etc.

A range of heavy-duty telescopic chassis mountings similar to those used in Admiralty equipment were shown by Hallam, Sleigh and Cheston and are capable of carrying evenly distributed loads up to 250 lb for extensions up to 2ft.

Makers*: A.B. Metal Products (S), Antiference (PS), Associated Electronic Engineers (TB), Belling & Lee (C, CRH, FU, PS, T, VH, VT), B.I. Callenders (C), British Electrical Resistance (K, S), British Mechanical Productions (C, CRH, MS, P, PS, ST, T, VB, VH, VP), British N.S.F. (S), Bulgin (C, FU, G, J, K, L, MS, PS, S, T, VH, VT), Carr Fastener (C, CRH, E, F, FU, L, MS, PS, ST, VH, VP, VT), Colvern (TB), Electrothermal (S, VR), Imhof (CH, P), Jackson (D), Labgear (CH, MS, P, S, VH), Long & Hamby (PS, RM, TM, VR), McDermido (K, VH), Oliver Peil (S), Painton (K,

PS, S, SP, T), Plessey (C, D, L, PS, S, SP, VH), Radio Instruments (VH), Reliance Electrical Wire (C, RM), Ripaults (T), Salford (D), Standard Telephones (C, S), Taylor Instruments (T), Telegraph Construction & Maintenance (C), Telephone Manufacturing Co. (J, PS), Truvox (S), J & H. Walter (CH, P), Walter Instruments (S, SP), Wingrove & Rogers (D), Wright & Weaire (S).

***Abbreviations:** C, connectors; CH, chassis; CRH, cathode-ray tube holders; D, drives; E, eyelets; F, fasteners; FU, fuseholders; G, group boards; J, jacks; K, knobs; L, lampholders; MS, mounting strips; P, panels; PS, plugs and sockets; RM, rubber mouldings; S, switches; SP, scale pointers; ST, solder tags; T, terminals; TB, terminal blocks; TM, television masks; VB, valve bases; VH, valve holders; VP, valve pins; VR, valve retainers; VT, valve top connectors.

CONTACT RECTIFIERS

The usefulness of the well-known metal rectifier has been extended by the introduction of types of higher voltage rating and of smaller physical dimensions. The Westinghouse Type 36E11T is intended for the supply to a cathode-ray tube or

units for currents of 1 mA to 10 mA. There are also Uniplate rectifiers intended for the low voltages of telecommunication circuits.

Metal rectifiers also find application in instruments, and four different patterns were shown by Salford, ranging from 200 µA to 50 mA.

Makers: Salford, Standard Telephones, Westinghouse.

VIBRATORS

Synchronous and non-synchronous vibrators for receiver H.T. supplies were shown on several stands, as well as complete vibrator power-supply units. The Plessey model is unusual in being designed for a 2-V input, and an overall efficiency greater than 50 per cent is claimed. The elimination of rubber from the vibrator has made it possible to adopt silver contacts and, to reduce losses. The output is 10 mA at 90 V, and 6 V for grid bias is available.

Makers: Bulgin, Plessey, Wimbledon, Wright & Weaire.

AERIAL EQUIPMENT

Detail improvements have been made in the mechanical design of television and anti-interference aerials and their fittings, and some firms are catering for the requirements of amateur transmitting enthusiasts. For example, Antiference, Ltd., have introduced a 300-ohm dipole with parallel wire elements embedded in polythene. The span is marked for cutting to the required length for the 10, 20 and 40 metre amateur bands and the 11, 13, 16, 19, 25 and 31 metre broadcast bands. A matching transformer is available if the aerial is to be connected to a broadcast receiver with an unbalanced input. The aerial is rated for power loadings of 1.9 kW at 7 Mc/s and 0.9 kW at 30 Mc/s.

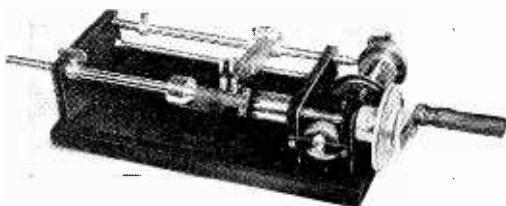

Labgear hand-operated wave-winding machine.

apparatus of similar power requirements. It will supply an output of up to 0.5 mA and is available in sizes ranging from 1.47-in long (1,600 V peak inverse) to 11.6-in (19,200 V peak inverse). All types are of 7/8-in diameter and are suitable for use with sine wave or pulse inputs of up to 50 kc/s. For really high voltages they lend themselves to the use of voltage-multiplying circuits. Heavier current types for lower voltages are suitable for receiver H.T. supply systems.

Standard Telephones & Cables showed selenium types. The E.H.T. models are of tubular construction and are rated up to 2 kV for single

Makers: Antiference, Belling & Lee, B.I. Callenders Cables, Labgear, Reliance Electrical Wire, Ripaults, Standard Telephones, Telegraph Construction & Maintenance.

SOUND REPRODUCTION

Loudspeakers. — In the highly competitive field of loudspeaker units for broadcast and television receivers the centre-pole type of magnet continues to hold its own for flux densities up to 10,000 gauss. With the active material concentrated in a compact lump and surrounded by a return path of "soft" steel, this design is not only economical, but has a very small external field and does not cause deflection in adjacent C.R. tubes. For high-powered P.A. and quality loudspeakers requiring fluxes above 10,000 gauss, ring-type magnets using anisotropic materials are favoured. More manufacturers are introducing shallow designs with the moving coil reversed and the magnet contained inside the angle of the cone diaphragm.

In the R. & A. "700" series the leads from the voice coil consist of beryllium-copper strips sandwiched between corrugated fabric centring diaphragms.

A new 12-inch speaker by Acoustic Products makes use of two independent diaphragms with separate voice coils.

Notable examples of heavy-duty loudspeaker were shown by Goodmans and Truvox. Goodmans were also showing a matched pair of loudspeakers consisting of a 12in unit for bass and 8in for treble.

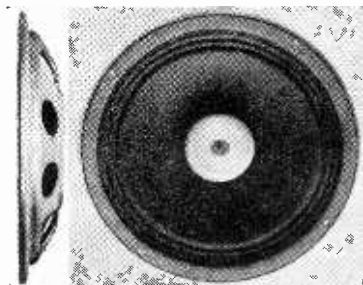

B.C.C. "Disc" loudspeaker.

The Truvox 12in heavy-duty loudspeaker is available with either copper or aluminium speech coil, the former giving balanced reproduction up to 8,000c/s and the latter up to 11,000c/s.

At the other end of the scale several interesting miniature loudspeakers were noted. The B.C.C. 2½in "Disc" speaker Model M21 weighs 2oz and is only ¾in thick. Even shallower is the Cosmocord

(Acos) RE5, which is driven by a bi-morph crystal and is suitable for incorporation in miniature "personal" portables. A neatly designed midget cabinet speaker (Model CT117) was seen on the Celestion stand. The dimensions are 6¼in x 4¼in x 2¾in, and the Bakelite case is available in a variety of colours.

To meet the demand of Continental radio-gramophone manufacturers for a 12in loudspeaker at a low price, Celestion have also introduced the Model 44 which is suc-

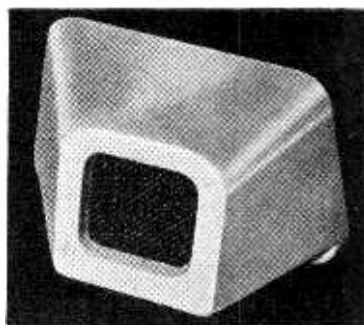

Celestion Midget loudspeaker.

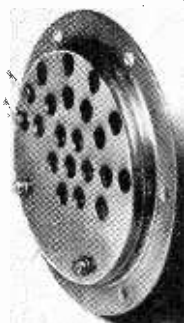

Cosmocord Model R.E.5. piezo-electric loudspeaker.



Ferranti ribbon pickup.



Garrard Model S.A.1 record player with radial tracking mechanism.

cessfully meeting foreign competition. The Model 44 has a 1½in voice coil and will handle 10 watts.

Makers: Acoustic Products, Brit. Communications Corp., Brit. Rola, Celestion, Electro Acoustic Industries, Goodmans, Plessey, Reproducers & Amplifiers, Resound, Taniou, Teledictor, Truvox, Vita-vox.

Gramophone Equipment. — The trend of design of pickups continues to move in the direction of even lighter moving parts and the use of permanent sapphire styli. Pickup manufacturers are keeping ahead of the requirements of wide frequency range recordings by designing ribbon movements capable of reproducing up to 18 or 20 kc/s.

A notable newcomer in this field is the Ferranti ribbon pickup which requires a vertical weight of only 5 gm (0.18 oz). The moment of inertia referred to the stylus tip is equivalent to a mass of 2.5 milligrams, and it is claimed that the pickup will track under accelerations of 1,000g. The stylus tip is elliptical and it is calculated that it will trace with low distortion wavelengths as short as 0.002in, corresponding to a frequency of 17kc/s at 78 r.p.m. and 5in diameter. An output of 3mV per cm/sec is obtained in 0.1MΩ. Naturally a pickup of this nature requires careful handling and an ingenious push-button mechanism has been devel-

Progress in Components—

oped for placing the pickup on 10in or 12in records.

Garrard have introduced an automatic single-record player (Model SA1) with a radial tracking mechanism. A switch mechanism in the motor spindle and another operated by the lid ensures that the motor does not start unless there is a record on the turntable and the lid is closed. The starting position of the pickup is automatically selected by the size of the record.

Makers*: Cosmocord (PU, RH), Garrard (M, PU, GU, RC), Plessey (PU, GU, RC), Radio Instruments (PU), Erwin Scharf (PU), Truvox (PU).

*Abbreviations: M, motors; PU, pickups; RH, recording heads; GU, gramophone units; RC, record changers.

Microphones. — Moving coil and ribbon microphones predominate for P.A. work and among new designs noted were the Tannoy MR/421 ribbon and the range of moving coil types shown by Reslosound. Piezo-crystal microphones for use in hearing aid formed an important section of the Cosmocord exhibit.

Makers*: Cosmocord, Reslosound, Tannoy, Vitavox.

Wire Recording. — A recording head designed for 0.004in diameter wire was shown by Associated Electronic Engineers. This consists of 0.020in Mumetal laminations with

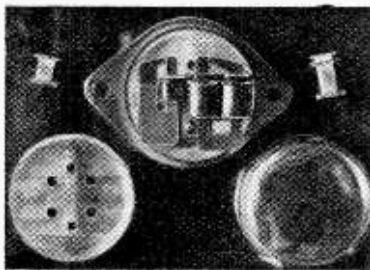

Magnetic wire recorder head (Assoc. Electronic Engineers).

two gaps and coils for recording, playback and erasure. The wire runs in a slot cut longitudinally in the edge of the lamination and is designed to pass knots and joints without jamming.

MATERIALS

Ceramics. — Precision moulded ceramic parts were displayed in the customary profusion and included minute, almost microscopic, spacers for use in the construction of miniature valves.

Magnetic Materials.—The technique of powder metallurgy as applied to magnets was exemplified by exhibits of moulded "Ticonal"

magnets by Mullard and "Alnico" by Murex. The process is economically justified for magnets weighing less than one ounce, and intricate designs can be made with greater facility than by casting.

Although no great changes were

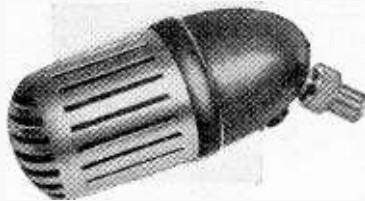

Tannoy MR/421 microphone.

noted in the varieties of high-permeability laminated materials available, there seems to be a tendency for suppliers to undertake more fabrication in the way of complete laminated assemblies, screening, boxes, etc.

Insulating Materials and Sleeving.

—The standard insulating materials were well represented and some conducting tape for internal screening in transformers was noted on the stand of H. D. Symons. The same firm was showing varnish-impregnated woven glass fabric sleeving with a dielectric strength of 25 kV/mm.

Cables.—Most of the R.F. cables used for television and developed

from war-time experience were again shown, and several firms were providing special cables for use in car radio installations.

Solder. — Activated rosin-cored solders in a wide variety of alloys were shown. Enthoven provided a large diagram illustrating the relationship between melting point and the lead/tin ratio. A useful range of indicator wires for testing soldering bit temperatures has been introduced by Multicore, who were also showing their method of testing fluxed joints for corrosion under conditions of 100 per cent humidity and with A.C. or D.C. traversing the joint.

Makers*: Associated Technical Manufacturers (C, CO, IM, IS, PVC, W), B.I. Callenders (C, CO, PVC, S, W), Bray (CE), British Rola (L), Bullers (CE), De la Rue (IM, IS, W), Du Bois (S), Duratube & Wire (B, C, IM, IS, PVC, W), Enthoven (S), Hellermann (IM, IS), Long & Hambly (IM), Magnetic & Electrical Alloys (DC, L, M), Micantite & Insulators (IM, IS, V), Mullard (M), Multicore (S), Murex (M, MO, T), Plessey (DC), Reliance Electrical Wire (B, C, CO, PVC, W), Ripaults (C, CO, PVC, W), Salford (DC), Scott (L), Spicers (IM, IS), Standard Telephones (C, CO, PCV, W), Steatite & Porcelain (CE), Suflex (IS, W), H. D. Symons (IM, IS, V), Telegraph Construction & Maintenance (C, IM, IS, L, M, W), Telephone Manufacturing Co. (DC), Taylor Tunncliffe (CE), United Insulator (CE).

*Abbreviations: B, braiding; C, cables; CE, ceramics; CO, cords; DC, dust cores; IM, insulating materials; IS, insulating sleeving; L, laminations; M, magnetic alloys; MO, molybdenum; PVC, polyvinyl chloride tapes, wires, etc.; S, solder; T, tungsten; V, varnished materials; W, covered wires.

List of Exhibitors

A.B. Metal Products, Ltd., Hatton Works, Feltham, Middx.
Acoustic Products, Ltd., 50-58, Britannia Walk, City Road, London, N.1.
Advance Components, Ltd., Back Road, Shernhall Street, London, E.17.
Antiference, Ltd., 67, Bryanston Street, London, W.1.
Associated Electronic Engineers, Ltd., Dalston Gardens, Stanmore, Middx.
Associated Technical Mfrs., Ltd., Vincent Works, New Islington, Manchester, 4, Lancs.
Automatic Coil Winder & Electrical Equipment Co., Ltd., Winder House, Douglas Street, London, S.W.1.
Belling & Lee, Ltd., Cambridge Arterial Road, Enfield, Middx.
Bird, Sidney S., & Sons, Ltd., Cambridge Arterial Road, Enfield, Middx.
Bray, Geo., & Co., Ltd., Leicester Place, Blackmans Lane, Leeds, 2, Yorks.
British Communications Corp., Ltd., Gordon Avenue, Stanmore, Middx.
British Electrical Resistance Co., Ltd., Queensway, Ponders End, Middx.
British Electrolytic Condenser Co., Ltd., 52, Vicarage Lane, Ilford, Essex.
British Insulated Callender's Cables, Ltd., Surrey House, Temple Place, Embankment, London, W.C.2.
British Mechanical Productions, Ltd., 21, Bruton Street, London, W.1.
British Moulded Plastics, Ltd., Avenue Works, Walthamstow Avenue, London, E.4.
British N.S.F. Co., Ltd., Ingrow Bridge Works, Dalton Lane, Keighley, Yorks.

British Rola, Ltd., Ferry Works, Summer Road, Thames Ditton, Surrey.
Bulgin, A. F., & Co., Ltd., Bypass Road, Barking, Essex.
Bullers, Ltd., 6, Laurence Pountney Hill, Cannon Street, London, E.C.4.
Carr Fastener Co., Ltd., Brantwood Works, Tariff Road, London, N.17.
Celestion, Ltd., London Road, Kingston, Surrey.
Colvern, Ltd., Mawneys Road, Romford, Essex.
Cosmocord, Ltd., 700, Great Cambridge Road, Enfield, Middx.
Daly (Condensers), Ltd., West Lodge Works, The Green, Ealing, London, W.5.
Dawe Instruments, Ltd., Harlequin Avenue, Great West Road, Brentford, Middx.
De la Rue Insulation, Ltd., Imperial House, 84, Regent Street, London, W.1.
Dubilier Condenser Co. (1925), Ltd., Ducon Works, Victoria Road, North Acton, London, W.3.
Du Bois Co., Ltd., 15, Britannia Street, King's Cross, London, W.C.1.
Duratube & Wire, Ltd., Faggs Road, Feltham, Middx.
Electro Acoustic Industries, Ltd., Stamford Works, Broad Lane, Tottenham, London, N.15.
Electrothermal Engineering Co., Ltd., 270, Neville Road, London, E.7.
Enthoven, H. J., & Sons, Ltd., Croydon Works, 230, Thornton Road, West Croydon, Surrey.
Erg Industrial Corp., Ltd., 1021a, Finchley Road, London, N.W.11.

A. C. Bridges

Their Principle of Operation in Terms of Vectors

By "CATHODE RAY"

FOR some reason unknown to me, books that discuss or explain A.C. bridges seldom make much use of vectors for

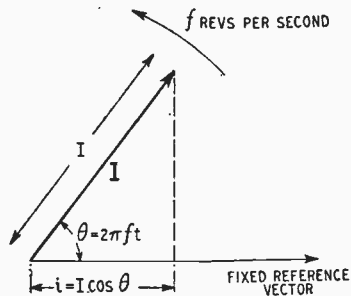

Fig. 1. I is a rotating vector representing a current of I amps at a frequency f c/s. The instantaneous value, i , at any time, t secs, after the start from the fixed reference, is given by $I \cos 2\pi ft$. Although this is the basic principle of vectors as applied to A.C., fixed vectors showing either peak or R.M.S. values are almost invariably used.

the purpose. If vectors are used at all, they are brought in rather half-heartedly. This seems strange, because it is only with the help of vector diagrams that I can follow A.C. bridges at all clearly. My remarks on j , the month before last, may have helped to get the thin end of the vector home among any who had hitherto shied at it. So now (mixing the metaphor still more) it may be a good opportunity to kill two birds with one stone—to help readers who are hazy about bridges, and to give an unhackneyed example of the use of vectors.

Just a few words of recapitulation. For the full story, consult the appropriate books.

An alternating current can be represented by a vector rotating at the frequency of the current. The length of the vector represents the peak value of the current, and its angle with some fixed vector (generally one pointing

at 3 o'clock) represents the instantaneous phase angle (θ) of the current (Fig. 1). The instantaneous strength of the current is represented by the projection of the rotating vector on the fixed reference vector. In other words, if I is the peak current and f its frequency, the length of the current vector should be I units to some convenient scale, and it should be imagined as rotating anticlockwise at f revs per sec. The instantaneous phase angle, t secs after the start, is then $2\pi ft$ radians. And the instantaneous current, i , is $I \cos \theta$. The vector itself is denoted by I , as distinct from i which is the numerical strength of the current irrespective of phase. (One may not always trouble the printer to bring out special type when the vectorial nature of the quantity

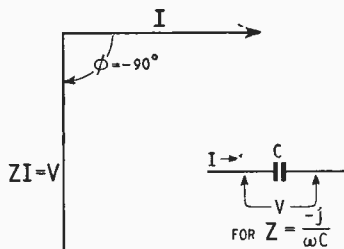

Fig. 2. Here are a pair of fixed vectors representing respectively current and voltage in and across an impedance consisting solely of capacitance. Current leads (i.e., is more anticlockwise than) voltage by 90° .

is obvious—as in Fig. 4 onwards—or unimportant.)

Generally we are not very much interested in the instantaneous values or phases, but we are interested in the peak value (or R.M.S. value, which is 70.7 per cent as large) and the phase of the current relative to other currents or voltages. So instead of making ourselves dizzy by trying to visualize the vectors

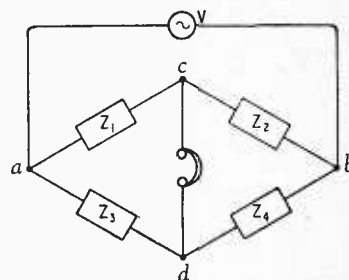

Fig. 3. Basic form of A.C. bridge.

all rotating at high speed, we freeze their motion and can then observe their relative phases. This is only possible, of course, if they are all rotating at the same speed; i.e., represent currents and voltages of the same frequency.

Given the current, the voltage across it is obtained (according to the extended Ohm's Law) by multiplying by the impedance. On the vector diagram the voltage vector is derived from the current vector by operating on it with the vector operator Z , which, as was explained in the February issue, is $R + jX$. Take the case of a purely capacitive circuit, in which $Z = -j/2\pi fC$ or $-j/\omega C$. The voltage vector is obtained by multiplying the current vector by $1/\omega C$ and rotating it $-j$, which is one right-angle backwards (i.e., clockwise), as in Fig. 2. As can be seen, this illustrates the well-known statement that a capacitive current leads the voltage by 90° .

In a purely inductive circuit the V vector would, of course, have to be turned in the opposite

Fig. 4. Vector diagram for balanced bridge (Fig. 3) in which Z_1 and Z_3 are resistances and Z_2 and Z_4 capacitances.

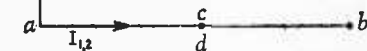

direction ($+j$), making it point vertically upwards, and it would

A.C. Bridges—

be ωL times as long as the I vector.

The effect of resistance is to make the relative phase angle, ϕ , less than 90° or $\pi/2$.

Just as Ohm's Law can be extended to include A.C. circuits, by substituting Z for R , so the principle of the original Wheatstone Bridge, intended for D.C., can be extended to include the great variety of A.C. bridges having the same general circuit (Fig. 3). The condition for balance is $Z_1 Z_4 = Z_2 Z_3$. When that happens there is no current through the detector, which means that the points c and d are at the same potential. Incidentally, so far as this condition for balance is concerned it makes no difference if the signal source and the detector (represented in Fig. 3 by a pair of phones) are interchanged. That is not to say it makes no practical difference which goes where; there are at least two things that may decide a choice. One of them has to do with stray capacitances, and the other with impedance matching; but at present we are considering only the main principle, not these side lines.

The interesting thing about A.C. bridges is that not only can resistance be measured in terms of resistance (as in the D.C. prototype), or capacitance against capacitance, or inductance against inductance; it is possible, and often very convenient, to measure any of these elements in terms of one of the others. Or one may wish to measure impedance in

fact, that is often more interesting than L or C itself.

To cover all sorts of measurement, dozens of variations on the main bridge theme (Fig. 3) have been devised. The question at the moment is to find the guiding principle which explains the whole lot, so that there will be no need to learn each one separately from scratch. For example, if it is desired to measure inductance in terms of a known fixed capacitance and resistances (fixed and variable), in which arms should they go?

Our starting point, or rather pair of points, is the applied voltage, which acts between a and b . So we can make the distance ab in Fig. 4 represent this voltage. It is applied to two paths in parallel— $Z_1 + Z_2$ and $Z_3 + Z_4$. Since we are assuming a balanced bridge, c and d are at the same potential, and the cross path through the detector can be left out of account. So there are two currents; one through Z_1 and Z_2 and equal to $\frac{V}{Z_1 + Z_2}$, and the other through Z_3 and Z_4 and equal to $\frac{V}{Z_3 + Z_4}$.

Our too-brief recapitulation said nothing about *dividing* by an impedance operator. But it is quite easy. The process is just the reverse of multiplying. To derive the current vector from the voltage vector, divide by the magnitude of the impedance, and rotate it in the direction opposite to multiplying. (The latter part is obvious vectorially; but in

about currents. There is no need to, if the two impedances in series in each path have the same phase angle; that is to say, if both Z_1 and Z_2 are pure resistance or reactance or have the same proportion of both. Similarly for Z_3 and Z_4 . The reason is clear from the diagram, Fig. 4. If the voltages across Z_1 and Z_2 (or Z_3 and Z_4) are in the same phase, their vectors must both be in the same direction, so the potential of the point c must lie on the straight line ab , dividing it into two parts proportional to Z_1 and Z_2 (or Z_3 and Z_4).

Take Z_1 and Z_2 , and suppose they are equal. Then (as the same current flows through both) the voltages across them must be equal, so the potential across them must be represented by the midpoint, c , in Fig. 4. The current vector may be anywhere from -90° to $+90^\circ$ from ab , depending on whether Z_1 and Z_2 are pure

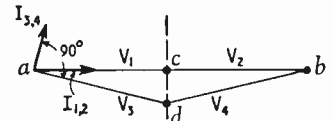

Fig. 7. Vector diagram for bridge which is unbalanced, although $Z_3 = Z_4$, because Z_4 includes resistance (represented by V_4 not being at right angles to $I_{3,4}$), while Z_3 does not.

resistance, or pure reactance (of either kind), or a mixture. If pure resistance, the current is in phase and lies along ab , as for example $I_{1,2}$. Now for balance d must coincide with c , so obviously Z_3 must be equal to Z_4 . And both must have the same phase angle. But there is no need for it to be the same phase angle as in Z_1 and Z_2 . It might be 90° leading, as shown by $I_{3,4}$. Notice, too, that there is no need for $I_{3,4}$ to be equal in strength to $I_{1,2}$.

The completed diagram, Fig. 4, corresponds to the common and quite useful De Sauty capacitance bridge, Fig. 5. If $R_1 = R_2$, then for balance the reactance of C_3 must equal the reactance of C_4 , so $C_3 = C_4$. And so for other ratios than 1:1 (but remember that $\frac{C_3}{C_4} = \frac{R_2}{R_1}$, not $\frac{R_1}{R_2}$, because X_C is proportional to $\frac{1}{C}$!). C_3 may be a standard against which C_4 , the

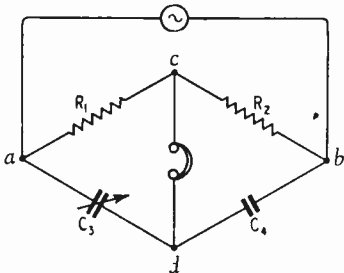

Fig. 5. Circuit diagram of bridge corresponding to Fig. 4.

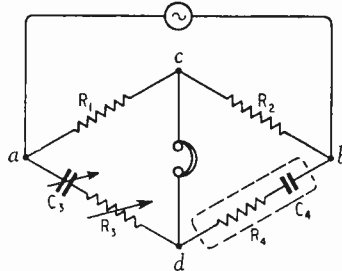

Fig. 6. Capacitance bridge with provision (R_3) for measuring capacitor loss (R_4).

general, in the $R + jX$ form. When measuring L and C , we generally want to know the resistance too, either directly or as a power factor or "Q." In

case it doesn't seem quite what one would expect algebraically, note that $1/j = j/j^2 = j/-1 = -j$.

For some of the simpler types of bridge one need not even bother

unknown, is compared. If C_4 has appreciable loss, its effect is the same as if there were a resistance in series (R_4 in Fig. 6). So it is necessary to put equal (assuming $R_1 = R_2$) resistance in series with

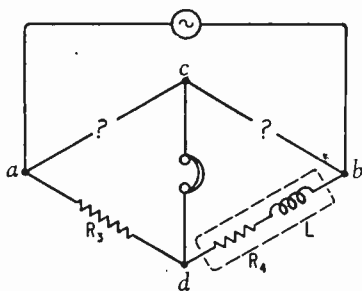

Fig. 8. If inductance is to be measured in terms of resistance and/or capacitance, how should they be arranged in arms 1 and 2?

arm 3. It is not enough just to make the impedance of arm 3 numerically equal to that of arm 4. For suppose that while Z_3 was (quite correctly) equal to Z_4 , Z_3 was a pure capacitance but Z_4 included some resistance. The path $Z_3 + Z_4$ as a whole would therefore have some resistance; i.e., in the vector operator equation $Z_3 + Z_4 = R + jX$, R would not be zero, and therefore there would be a component in phase with the voltage as well as one at right angles. So when the voltage vector was divided by $Z_3 + Z_4$ to give the current vector, its angle with cb would be less than 90° , as perhaps in Fig. 7. Considering now the separate voltages across R_3 and R_4 ; as Z_3 is a pure capacitive reactance, V_3 must be at right angles to the current through it; $I_{3,4}$, as represented by ad . So d , although midway between a and b , no longer coincides with c , and the bridge is out of balance. The effect of inserting some resistance into arm 3 is to reduce the angle between $I_{3,4}$ and V_3 ; when V_3 is in line with V_4 , then $R_3 = R_4$. The effect of varying C_3 is to shift point d horizontally along ab , and the effect of varying R_4 is to shift d vertically. An out-of-balance due to C_3 being wrong cannot be compensated by any possible adjustment of R_3 . Just as the label " j " keeps X in a separate compartment from R in all calculations, so they work separately in actual measurements.

Which means that a bridge of this kind enables Z (i.e., $R + jX$) to be measured; not merely Z .

As a matter of fact, the value of C_3 (and therefore C_4) is usually known as a capacitance, not as a reactance, though of course the reactance X_C can easily be derived for any particular frequency, because it is $1/2\pi fC$. That raises another interesting point. Suppose the generator produces a signal with more than one frequency. It might be an oscillator with strong harmonics. The C_3 and C_4 have more than one reactance at the same time. That is all right if there is no resistance, because the various pairs of reactances are all in the same ratio. So one can use a buzzer or other A.C. source with a poor waveform. (There is a possible slight qualification if either C_3 or C_4 varies appreciably with frequency). It is all right even if there is resistance, provided that the ratio of resistances is the same at all the frequencies. Since the standards will generally be designed to have the same C and R at all frequencies, any variability of the unknown with frequency will make the bridge unbalanceable unless either the source has a

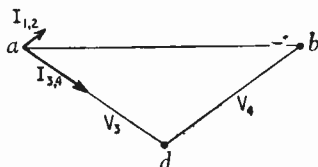

Fig. 9. Diagram for Fig. 8, showing a possible current vector which would enable arms 1 and 2 to balance 3 and 4.

pure waveform or the detector can be made to ignore all but one frequency.

So much for C and R . How about L ? The same argument holds good for L as for C ; but in practice it is generally difficult and inconvenient to provide a standard inductor. Whereas a standard capacitor can be made to have negligible R for most purposes, an inductor inevitably has a substantial amount of R in itself, so if the coil to be measured happens to have less R it is impossible to balance the bridge. That is why various types of bridge have been devised to measure L in terms of the more convenient standards of C and R .

And that is also where vector diagrams are particularly helpful.

It is quite clearly impossible to balance an inductive arm 4 by a capacitive arm 3, because the voltages across L and C in series are

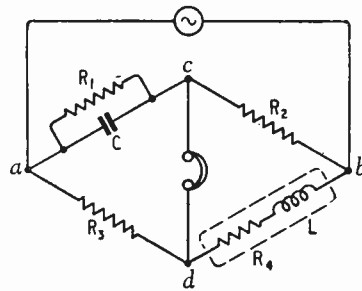

Fig. 10. Derivation of a bridge (Maxwell) from Fig. 9.

in opposition and certainly can never be brought into line along ab . The solution is to make c and d coincide off ab . Suppose the inductive unknown in arm 4 is balanced by a resistance in arm 3, as in Fig. 8. The path adb as a whole is inductive, so j is positive; dividing by $+j$ is the same as multiplying by $-j$, so the current vector $I_{3,4}$ lags the voltage across ab , as shown in Fig. 9. The voltage V_3 across R_3 must be in phase with the current; which gives the direction of V_3 ; and assuming for simplicity that $Z_3 = Z_4$, the position of d is fixed equidistant from a and b .

How now do we make point c coincide with d ? It can be done of course, by making arms 1 and 2 identical with 3 and 4; but we are trying to avoid another inductive arm. If the Z_1Z_2 path is capacitive, $I_{1,2}$ must be leading, as in Fig. 9. And if arm 1 is all resistance it is in phase with $I_{1,2}$, which is no good. The arm in phase with $I_{1,2}$ must coincide with V_4 ; it must be arm 2. If then arm 1 is capacitive, so that $I_{1,2}$ leads the voltage across it (V_1), there should be no difficulty in making V_1 coincide with V_3 . Inductance in one arm, therefore, can be balanced by capacitance in the diagonally opposite arm.

The result is the Maxwell bridge (Fig. 10) for balancing C against L . It should be quite an easy extension of the above reasoning to show that the resistance in arm 4 can be balanced by resistance in arm 1. This R_1 is usually connected in parallel with C as shown.

A.C. Bridges—

If $L = 0$ and $C = 0$, it simplifies down to an ordinary Wheatstone bridge, in which $R_1 R_4 = R_2 R_3$, and c and d lie on ab . The effect of C and L is to move points c and d respectively off ab . Because C is in parallel with R_1 it is not very easy to work out the balance relationship between L and C from the vector diagram, even although the relationship itself is about as simple as it could be ($L = CR_2 R_3$) and the $R_1 R_4 = R_2 R_3$ relationship is unchanged. To prove this by algebra will give you some practice in the use of j . You start with $Z_1 Z_4 = Z_2 Z_3$ and substitute the appropriate $R + jX$ throughout, remembering that, in arm 1, R and X are in parallel, and that the j terms and the j -less terms can be separately equated.

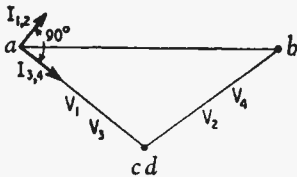

Fig. 11. Alternative current vector $I_{1,2}$ for balancing arms 3 and 4 in Fig. 8.

An advantage of the Maxwell bridge is that frequency does not come into the balance condition, so one need not be very particular about the waveform of the signal source. But a disadvantage is that if you adjust $R_2 R_3$ you affect the balance for both R_4 and L ; so if you are in balance for one and not for the other, any further adjustment will throw the bridge out of balance for whichever was right. This little peculiarity makes it a rather exasperating bridge to use.

So let us examine just one more bridge by the vector method. We have seen that what is wanted in the acb path to balance inductance in arm 4 is a turn to the left in the vector diagram on passing from arm 1 to arm 2. The obvious but unpractical way is to make arm 2 inductive to match arm 4. The Maxwell way is to make arm 1 less inductive, i.e., capacitive. Still another way is to start off with arms 3 and 4 (inductance in 4) and assume that arms 1 and 2 balance it. If the two currents are in phase we get the inductive

arm 2, already rejected. But try shifting $I_{1,2}$ 90° clockwise (Fig. 11). As the current now leads the

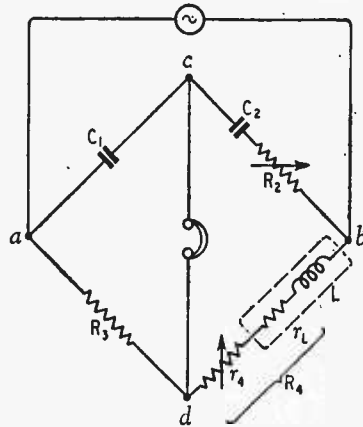

Fig. 12. Derivation of a bridge (Owen) from Fig. 11.

voltage by 90° in arm 1, Z_1 must be purely capacitive. And with no L in arm 4, Z_2 would have to be capacitive too, i.e., Fig. 5 upside down. With Z_4 purely inductive, Z_2 would have to be all R . So C_2 balances R_4 and R_2 balances L —a very convenient arrangement known as the Owen bridge (Fig. 12). Generally L is balanced by a variable R_2 and its resistance r_L by a reduction in r_4 .

The condition for balance in the Owen bridge can be worked out by the j method (very easy this time because everything is in series), or from the vector diagram by analysing V_2 and V_4 into their in-phase and 90° components. This is done by producing ac to e where aeb is a right angle (Fig. 13). Then ce represents the part of V_2 that is at right angles to the current, $I_{1,2}$, and therefore reactive, ($I_{1,2} X_2$). It also represents the part of V_4 that is in phase with

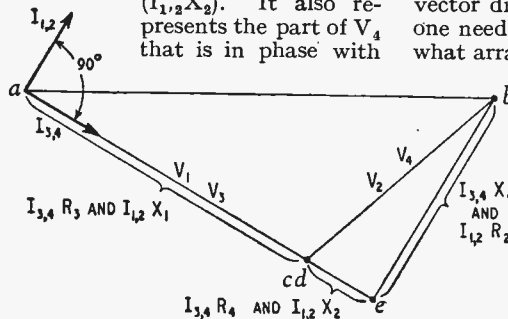

Fig. 13. Completed Fig. 11, showing geometrical construction for discovering conditions of balance in Owen bridge.

$I_{3,4}$, and therefore resistive ($I_{3,4} R_4$). Similarly for eb . So we get the proportion

$$\frac{R_3}{X_1} = \frac{R_4}{X_2} = \frac{X_4}{R_2}$$

$$\text{or } R_3 \omega C_1 = R_4 \omega C_2 = \frac{\omega L}{R_2}$$

The ω 's cancel out, leaving

$$L = R_2 R_3 C_1$$

$$R_4 = R_3 \frac{C_1}{C_2}$$

$$\text{So } r_L = R_4 - r_4 = R_3 \frac{C_1}{C_2} - r_4$$

As with the Maxwell bridge, frequency does not come into the matter; but unlike the Maxwell bridge the adjustments for balancing L and r_L (by R_2 and r_4 respectively) are quite independent, and it is an easy bridge to adjust. Moreover, variable resistances are the easiest accurate standards to provide for a wide range of values. And C_1 and C_2 , being fixed, can be made much larger than C in the Maxwell, so that their reactances match the other impedances of the bridge better and are less affected by

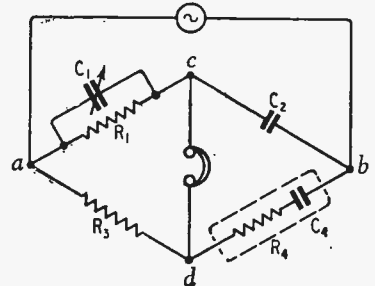
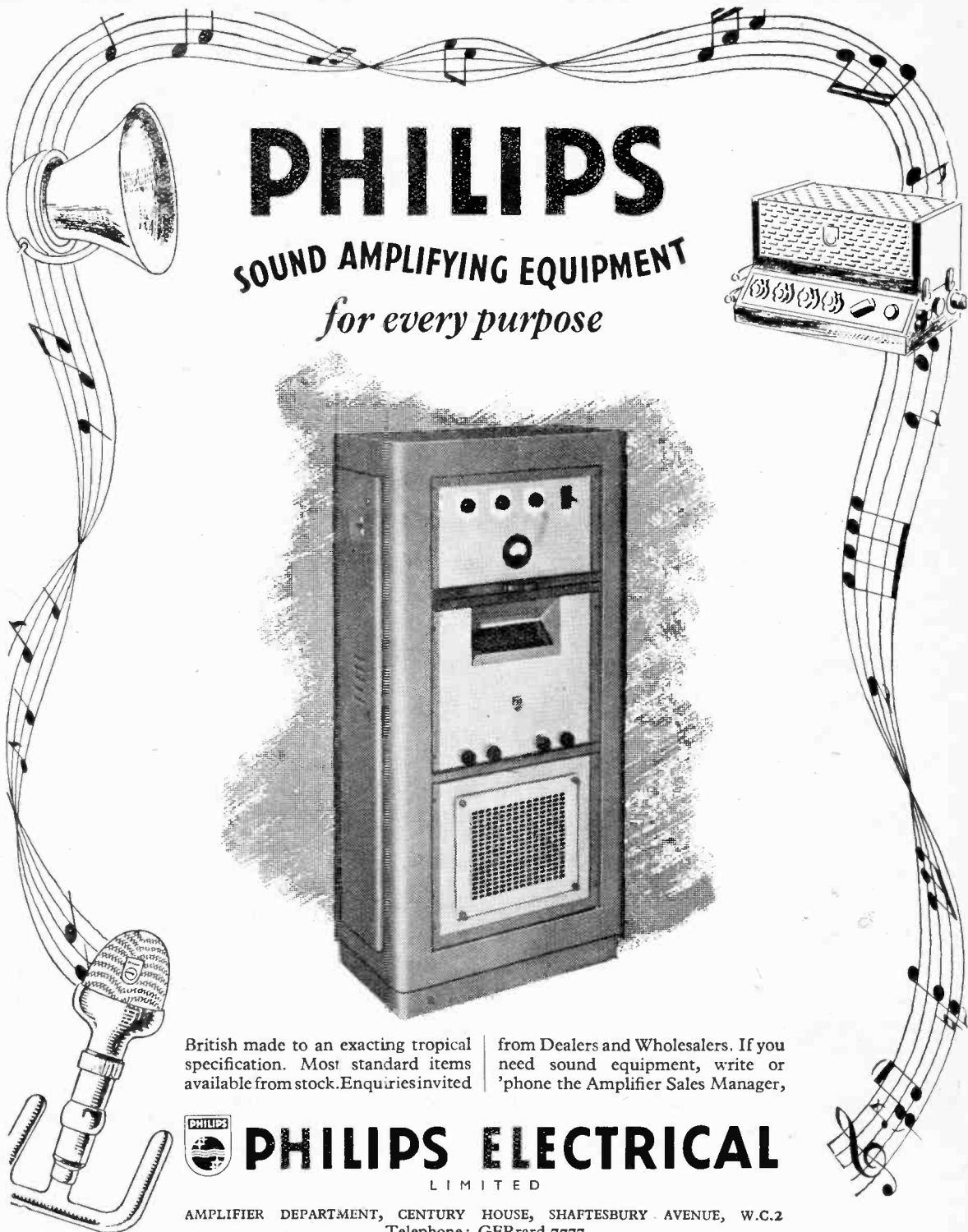

Fig. 14. Schering bridge.

stray capacitances. Only one of them need be an accurate standard. So altogether it is a very satisfactory type of bridge.

When once the idea of the vector diagram has been grasped, one need never be in doubt about what arrangements of bridge arms

are capable of balance, and which element in one arm balances any other in any other. It also gives one a helpful picture of the j algebra processes. If you are interested, try the Schering bridge next (Fig. 14). It is a valuable one for measuring the losses in capacitors, especially at high voltage.



PHILIPS

SOUND AMPLIFYING EQUIPMENT

for every purpose

British made to an exacting tropical specification. Most standard items available from stock. Enquiries invited

from Dealers and Wholesalers. If you need sound equipment, write or 'phone the Amplifier Sales Manager,



PHILIPS ELECTRICAL

LIMITED

AMPLIFIER DEPARTMENT, CENTURY HOUSE, SHAFTESBURY AVENUE, W.C.2
Telephone: GERrard 7777

April is a notable month

first All-Fools' Day, then the Budget

WE MAY NOT KNOW WHAT IS IN STORE FOR US, BUT WE CAN BE CERTAIN OF QUALITY WITH "SOUND SALES"

FOR RELAXATION

THE ELECTROGRAM with finger tip electronic tone controls.

THE PHASE INVERTER SPEAKER, which led the field in acoustic cabinet devices — and is still leading.

FOR HOME CONSTRUCTION and built-in Radio

FEEDER UNITS.

D.X. PLUS SEVEN QUALITY CHASSIS.

TONE CONTROL UNITS.

INHERENTLY BALANCED PUSH-PULL QUALITY AMPLIFIERS from 6W to 50W.

TRANSFORMERS AND CHOKES of all types.

FOR INDUSTRIAL PURPOSES

BATTERY CHARGERS.

FACTORY SOUND INSTALLATIONS including the new Auto-call System.

RACKS AND PANELS.

AGENTS :

Barnes & Avis, Reading; Bowers & Wilkins, Worthing; Binns Ltd., Newcastle; Dalton & Sons, Ltd., Derby; Clark & Sons, Isle of Wight; Hickie & Hickie, Ltd., Reading (and branches); Thomas Lynn & Sons, Andover; Merriots Ltd., Bristol; Needham Engineering Ltd., Sheffield; Pank's Radio, Norwich; Sound Ltd., Cardiff; Bernhard Smith, Barnstaple; Sound Services, Jersey, C.I.; Precision Services, Edinburgh; Seals Ltd., Southsea; G.E. Samways, Hazel Grove; Weybridge Radio Electric, Weybridge; West End Radio, Farnham; Vallance & Davison, Ltd., Leeds (and branches).

Overseas Stockists in :

Canada, South Africa, Channel Islands, etc.

When you see the word "SOUND" think of

Sound Sales Ltd.

57, St. Martin's Lane, London, W.C.2

(TEMPLE BAR 4284)

WORKS : Farnham, Surrey. (FARNHAM 6461/2/3)

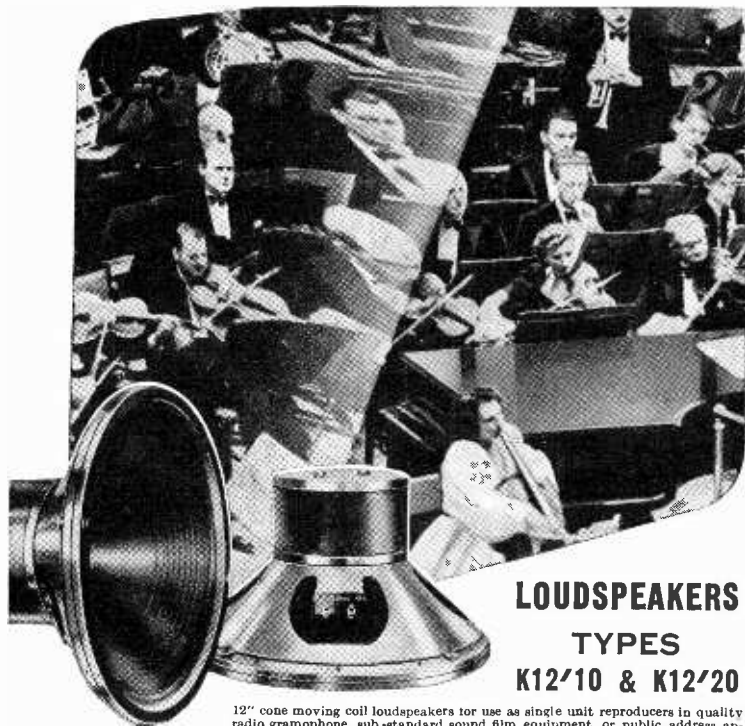

ELIMINATE SOUND DISTORTION

Can distortion be eliminated? Not quite, of course, but it can be reduced to a minimum by the use of loudspeakers which will introduce as little discoloration as possible—well designed loudspeakers—Vitavox loudspeakers in fact.

LOUDSPEAKERS TYPES K12/10 & K12/20

12" cone moving coil loudspeakers for use as single unit reproducers in quality radio gramophone, sub-standard sound film equipment, or public address apparatus or as the low frequency section of a dual channel system, the K12/10 and K12/20 loudspeakers incorporate high efficiency ticonal magnets, accurately

centred poles, and inter-changeable diaphragms impregnated to resist moisture.

Type	Power Handling Capacity	Total Flux	Impedance
K12/10	10 watts	140,000 lines	15 ohms
K12/20	20 watts	170,000 lines	15 ohms

VITAVOX

MANUFACTURERS OF SOUND EQUIPMENT

VITAVOX LIMITED
Westmoreland Road, London, N.W.9.
Tele : COLindale 8671-3

WORLD OF WIRELESS

“Special” Licences ♦ B.B.C. Progress ♦ Midland Television Tests ♦ Wages Again

“ BUSINESS RADIO ”

IT is learned on enquiry from the Post Office that fifty “Business Radio Licences” have so far been issued by the P.M.G. and that about half of them are for taxi services in various parts of the country—four are in London.

As previously stated, these licences are issued in very limited numbers for such concerns as towage companies, railways, public utility vehicle services, newspapers and taxi hire services, and also to professional men, such as doctors. The initial cost is £5, plus another £5 for each transmitter-receiver.

Fifteen frequencies between 67 and 87Mc/s have now been allocated for the use of the Press. These frequencies are for mobile equipment, which must operate within ± 25 kc/s of the allotted frequency. In addition, one channel (76.9-77.0Mc/s) has been allocated for low-power walkie-talkie type equipment.

Applications for “Press” frequencies had to be made to the Joint Telecommunications Committee of the Newspaper Society and the Newspaper Proprietors’ Association by March 7th, who will advise the G.P.O. on the allocation of licences. It is understood that 22 applications from representatives of 83 newspapers and two news agencies have been received.

Applications for “Business Radio Licences” should be made to the Director, Overseas Telecommunications Department, Broadcasting Branch, G.P.O. Headquarters, London, E.C.1, who has the supervision of all radio frequency allocations.

B.B.C. REPORT

THE annual Report of the Governors of the B.B.C. for the year ended March, 1947, was recently issued as a White Paper (Cmd. 7319). It states that, in addition to the erection of the F.M. station at Wrotham and the Birmingham television station, which are in hand, the Corporation has a number of substantial development schemes, which, because of present conditions, cannot be started. “The major schemes involved are the erection of a series of television and F.M. stations, Broadcasting House extension, new regional headquarters and a new centre in London

to provide for the development of television and for the grouping of other broadcasting activities at present scattered throughout London.”

The story of progress in the technical field during twenty-five years of broadcasting is told briefly by H. Bishop, B.B.C. chief engineer, in the *B.B.C. Yearbook*, 1948, which has just been published.

In another chapter reviewing the year’s work of the engineering division reference is made to F.M. test transmissions in the 45- and 90-Mc/s bands in various parts of the country which are continuously recorded on automatic field-strength recorders at distances up to several hundred miles. F.M. transmissions from Alexandra Palace continue on a mean carrier frequency of 90.3 Mc/s.

AMATEUR BAND PROPOSALS

A PLAN has been submitted to the International Amateur Radio Union and all I.A.R.U. societies in Europe by the R.S.G.B. outlining proposals for the sub-division between telephony and telegraphy of the five amateur bands between 3.5 and 28 Mc/s.

The Society states that it recognizes that any form of band planning will fail unless it is introduced into the licence and enforced by the respective licensing authorities. For this reason the European societies have been asked, when commenting on the plan, to indicate whether they consider that their licensing authority will agree to make the plan mandatory if it is finally adopted.

LONDON-BIRMINGHAM RADIO LINK

PROPAGATION tests are being conducted by the G.E.C. over the route of the London-Birmingham television radio-relay link to investigate signal strength stability and the interference level at the various sites.

Two mobile laboratories with temporary masts are being used for the tests. Each mast is fitted with a cradle to carry the 14-ft diameter paraboloid aerial system. This cradle can be raised and lowered to investigate variations in the received signal strength at various heights.

Communication is maintained between the two units on decimeter wavelengths, for which the small

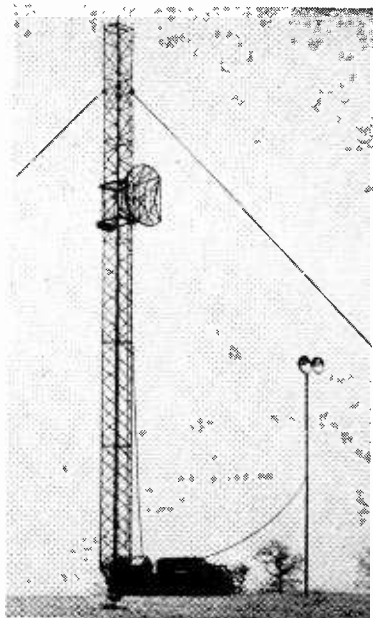

TEMPORARY MAST with elevated paraboloid aerial used during the G.E.C. television field trials.

portable mast shown in the photograph is used.

The results of these trials will also provide useful data for multi-channel radio-telephony systems.

½-MILE TELEVISION TOWER

ONE of the most ambitious projects yet suggested for extending the range of television has been launched in the U.S.A. It is proposed to erect a tower 2,650 feet—over half-a-mile—high in the vicinity of New York, and to install at the top a number of transmitters. William van Alen, architect, with W. Ralph Squier, civil engineer, are responsible for the design. Associated with them are: Ralph Batcher, executive editor of *Electronic Industries*, and Louis G. Pacent, radio consulting engineer.

It is planned to use the tower for other radio services, including F.M. Estimated coverage would extend over the whole of Long Island, most of New Jersey, and parts of Connecticut and Pennsylvania.

PHYSICAL SOCIETY'S SHOW

TICKETS for admission to the Physical Society's 32nd annual exhibition of scientific instruments and apparatus, which opens at the Imperial College, South Kensington, London, S.W.7, on April 6th, are available from Fellows of the Society, exhibiting firms and most of the learned societies. The tickets are valid for the sessions indicated

World of Wireless—

—10.0 to 1.0 or 2.0 to 8.0. On the first day the exhibition will be open from 2.0 to 9.0. The exhibition closes on the 9th.

YOUNG TECHNICIANS' PAY

AS a result of an agreement between the Association of Scientific Workers and the Engineering and Allied Employers' National Federation, young technical workers in the engineering industry now receive a minimum wage at the age of 21. The agreement provides for the following minima, plus a 29s 6d cost of living bonus: London, £3 19s 6d; the Provinces, £3 14s 6d.

The Federation is to recommend its members to make additional payments in recognition of suitable qualifications.

EXPORT TARGET HIT

FOR the first time during last year the industry's export target of "a million a month" was hit in December. The total value of all kinds of radio equipment exported during the month was £1,013,162 which brought the year's total to £10,271,716. The approximate figures for 1946 and 1938 were eight million and two million respectively.

Broadcast receivers and radio-gramophones accounted for nearly half the year's exports.

The component manufacturers exceeded their monthly export target of £190,000 by some £46,000 in December making the year's total £2,095,008.

TELEPHONE RECORDING

THE final order of the U.S. Federal Communications Commission prescribing the conditions under which it is now permissible to use telephone recording devices in the U.S.A. has recently been issued.

The main features can be summarized as follows:

(1) An "approved" type of recording device must be used; i.e., it must be a device capable of warning all parties to the telephone conversation that the conversation is being recorded; adequate notice that the conversation is being recorded must be provided by an automatic tone signal, of higher frequency than the ordinary "busy" signal (1,400 c/s).

(2) Unapproved types of recorders are illegal and telephone companies may refuse to serve subscribers known to be using these.

(3) The order relates to telephone recording devices on interstate telephone communications, but it is generally accepted that it will become the basis of regulations concerning recording devices on all telephone circuits.

INSTITUTE OF RECORDED SOUND

A MEETING, arranged by the Association of Special Libraries and Information Bureaux (ASLIB), was held in London on March 3rd interested to discuss the formation of an Institute of Recorded Sound. The formation of such an institute, providing a permanent storehouse for all forms of recorded sound was agreed in principle.

Among the nine members of the committee appointed to investigate the plan in detail and make a report are: H. L. Fletcher (Association of Professional Recording Studios), Dr. L. E. C. Hughes (British Sound Recording Association), and A. C. Cameron (Educational Department, Electric and Musical Industries).

CONSOL ERROR

THE Ministry of Civil Aviation advises that observations of the transmissions from the Bushmills, N. Ireland, consol beacon taken at sea confirm that there is a possibility of large errors if a loop receiving aerial is used near the null position for direction finding. In conditions where a horizontally polarized component is present the use of a loop near the null position may lead to errors in count of twenty or more characters. Automatic gain control must be switched off when receiving Consol signals.

U.S. ELECTRONICS CAPITAL

THE vast manufacturing and research centre for General Electric of America, some six miles from Syracuse, N.Y., on which work was started two years ago, is now

complete. The G.E. Electronics Park, as it is called, covers 155 acres, of which 30 acres are occupied by the main buildings.

As will be seen from the annotated photograph of a model of the centre the receiver and transmitter buildings are the largest. When in full production the peak output from the ten assembly lines in the receiver building will be 800 table models, 200 consoles or 100 television receivers a day.

Valves and heavy industrial electronic equipment continues to be manufactured in Schenectady.

PERSONALITIES

T. A. Davies has been appointed G.P.O. inspector of wireless telegraphy in succession to Col. A. H. Read (see note below). He was deputy inspector from 1940 to 1944, when he was appointed a principal in the G.P.O. overseas telecommunications department.

A. J. A. Gracie, who as assistant secretary of the G.P.O. overseas telecommunications department was a delegate to last year's Atlantic City conferences, has been appointed as U.K. representative on the International Frequency Registration Board, and recently left for Switzerland, where the Board has its headquarters.

Walter G. Powitzer, chief studio engineer of the Palestine Broadcasting Service, Jerusalem, since its formation in 1935, has relinquished his post as assistant engineer, Posts and Telegraphs, and is returning to this country. During the war he was working for the Psychological Warfare Branch of the U.S. Army in its "Freedom" stations.

Col. A. H. Read, O.B.E., who has been G.P.O. inspector of wireless telegraphy since January, 1945, has been appointed deputy regional director of the G.P.O. London telecommunications region. He was deputy inspector



ELECTRONICS PARK, the twenty-five million dollar manufacturing and research centre of General Electric at Syracuse, N.Y.

for fifteen years. As recorded elsewhere in this issue, he was among the delegates to the Atlantic City conferences.

Morris Reed, Ph.D., M.Sc., M.I.E.E., has been appointed chief radio engineer at Philips' Mitcham works, where he will be in charge of all engineering activities relating to radio and television apparatus. From 1929 to 1946 Dr. Reed was with Siemens Brothers, where he held successively



DR. MORRIS REED.

the positions of head of the wireless laboratory, chief radio engineer and assistant to the chief engineer, telecommunications department. For a short time after leaving Siemens he was general manager of R.F. Equipment, Ltd.

R. Salmon, formerly managing director of R.S. Amplifiers, Ltd., is leaving for Australia on March 31st and will open offices in Sydney, New South Wales. He will be glad to assist British manufacturers wishing to increase their Australasian interests. Enquiries should be addressed c/o Phillips Advertising, Ltd., Thanet House, Craven Road, London, W.2.

Len Schultz, chief engineer of the Macquarie Broadcasting Network of Australia, which comprises some forty-five radio stations, is on a visit to this country to study F.M. and television.

W. C. Stevens has been elected general secretary of the Electrical Trades Union. He was for some years sound maintenance engineer in a film production and renting company.

Dr. M. J. Strutt, D.Tech.Sc., electronics consultant to the N. V. Philips Co., Eindhoven, has been appointed professor in the Faculty of Electricity at the Federal Swiss Institute of Technology at Zurich. Dr. Strutt has contributed many articles to our sister journal *Wireless Engineer*.

OBITUARY

It is with regret we record the death of **Cyril H. Hunt,** chairman and managing director of A. H. Hunt, Ltd., the well-known manufacturers of capacitors. He was aged 50 and the only son of the founder of the company. He died suddenly whilst travelling to his office with his wife and father.

IN BRIEF

Receiving Licences.—January's total of 12 television-and-sound receiving licences was approximately 39,000, which is an increase of 6,300 over the previous month—a record month's increase. The number of broadcast licences in force in Great Britain and Northern Ireland, including the above, was approximately 11,195,800.

Price Freezing.—Broadcast receivers, television sets, radiogramophones, components and accessories for each of these, and gramophone records are included in the list of goods in the Miscellaneous Goods (Maximum Prices) Order, 1948, which, together with thirteen other Orders, fixed the prices of the vast majority of consumer goods in this country from March 15th.

U.K.-N.Z. Facsimile.—The world's longest phototelegraph circuit, between London and Wellington, was opened by Cable and Wireless on March 1st. Pictures are automatically relayed via Colombo.

B.I.F.—A model of the radar-equipped harbour at Douglas, I.O.M., which was recently opened, will be on view in the radio section of the British Industries Fair at Olympia. The Music and Radio section will this year occupy 3,000 sq ft more than last year. The fair opens on May 3rd.

A.F.N.—The wavelengths of the Frankfurt and Bayreuth transmitters of the American Forces Network in Germany were changed at the end of February. Frankfurt is now on 499.2 metres (601 kc/s) instead of 212.6 metres, and Bayreuth on 212.6 metres (1,411 kc/s) instead of 249.2 metres.

Professional Association.—At a meeting of the Engineers' Guild on March 10th, which was attended by some 400 chartered electrical, civil and mechanical engineers, a resolution, proposed by Sir Stanley Angwin, to the effect that the Guild is capable of fulfilling all the non-technical requirements of professional engineers and should have the active support of the entire corporate membership of the three senior institutions, was agreed. It is stressed that the Guild, which was founded in 1938, is non-political and is not a trade union. The offices of the Engineers' Guild are in 28, Victoria Street, London, S.W.1.

Vacation Courses, lasting three weeks and consisting almost entirely of laboratory and workshop work, are held by E.M.I. Institutes, 44, Grove Park Road, London, W.4, during the Easter and Summer vacations. They are designed primarily as a follow-up to the postal courses in Basic Radio and Basic Television. Separate courses are held for radio and television receivers and they include work on a wide range of modern receivers of various makes. The fee for the next course, which begins on March 30th, is £6 16s 6d.

"The Trader" Jubilee.—It is with pleasure we record the silver jubilee of our associated journal *The Wireless and Electrical Trader*, which was first published monthly in March, 1923.

Mechanical Handling.—As mentioned last month, our associate journal *Mechanical Handling* is organizing the first National Mechanical Handling Exhibition, which will be held at Olympia

RE-ENTRANT HORN TYPE 42 REH

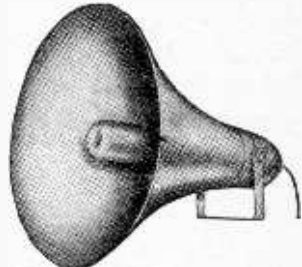

The new 42REH has advantages of complete weather-proofness, smaller overall length, better weight distribution and consequently greater ease in handling, which make this one of the most popular of the new F.I. loud-speakers. The horn is designed for use with the standard F.I. L.S.7 Unit and allows for this unit to be driven to 12 watts input. A spun aluminium cover over the unit has room for housing a suitable matching transformer.

The construction has been designed so that the whole unit is assembled and held together with ONE LARGE NUT only. This construction enables a number of units to be packed for export in a space which is a fraction of that normally required; assembly is a matter of a few minutes unskilled labour.

This unique feature will recommend itself to all export buyers particularly.

The 42REH is not of the "loud-hailer" type of speaker, but is designed to cover a range of frequencies considerably greater than those needed for purely "announcing" purposes; i.e., it is suitable for all normal requirements of high power reproduction of music as well as speech.

Dimensions assembled ...	22in. dia. x 24in.
Bell diameter ...	22in.
Cut-off frequency ...	175
Effective Air Column ...	42in.
Weight Horn only ...	8 lbs.
Shipping space ...	One—23in. x 23in. x 18in. 12—33in. x 33in. x 27in.

F.I. for P.A.
FILM INDUSTRIES LTD.
60, PADDINGTON ST., W.1
Telephone: WELbeck 2385

World of Wireless—

from July 12th to 21st. Seventeen papers covering various aspects of mechanical handling will be presented at the convention, which will be held concurrently with the exhibition.

A Weakness.—A notice to airmen from the Ministry of Civil Aviation states that whip aeriels have a tendency to fracture at the point where the type number or other trade mark has been stamped or "indented" in the metal during manufacture. Whip aeriels so marked are not to be fitted to British Civil Registered aircraft.

World Broadcasting.—A useful book has been produced by the Editor of our Danish contemporary, *Populaer Radio*, giving information on the organization and activities of the broadcasting systems of the world. "World Radio Handbook for Listeners," as it is called, gives, in its 96 pages, details of each country's broadcasting stations, times of transmission, address of operating concern and the difference between local time and G.M.T. A list giving the world's stations in order of frequency is also included. The book, which will be published in May and November, costs 5s.

Navigation.—The Institute of Navigation, which was formed a year ago to "promote the interest of science and practical navigation by uniting together in a scientific body those who are concerned with, or are interested in, the art of navigation," has issued a *Journal*. It will be published quarterly and contains papers read at meetings of the Institute, together with the ensuing discussions. It is obtainable from John Murray, 50, Albemarle Street, London, W.1, price 6s 3d, including postage.

Television Française.—We were misled regarding the manufacturer of the equipment used in the Eiffel Tower television station. It was manufactured and installed by Le Matériel Téléphonique. During the war this equipment was partly dismantled by the Germans, but was repaired soon after the liberation of France.

INDUSTRIAL NEWS

"Clix."—Sales of Clix radio and television components will, from April 1st, be handled by General Accessories Co., 21, Bruton Street, London, W.1. The new company is a subsidiary of British Mechanical Productions, Ltd., the manufacturers.

G.E.C. has been given a £20,000 contract to provide a F.M. mobile radio-telephone system for the Netherlands police. The equipment, which is similar to that used by our own Police Forces, will comprise ten 100-watt fixed transmitter-receivers, five 10-watt fixed stations and fifty-two mobile units. The system will operate on a frequency around 80 Mc/s.

H.M.V.—Three new receivers for the home market were exhibited on the H.M.V. stand at the *Daily Mail* Ideal Home Exhibition, Olympia. They were Models 1407, a 4-valve transportable battery superhet; 1608, a 4-valve (+rectifier) push-button auto-radiogram with twin speakers; and 1117, a table version of 1608.

Marconi Instruments.—A display of new communication test equipment will be staged by Marconi Instruments, Ltd., at their London showrooms, 109, Eaton Square, S.W.1, from April 6th to 16th. The instruments shown will be additional to those presented at the Physical Society Exhibition (April 6th-9th). It will be open on weekdays between 10 a.m. and 5 p.m. A demonstration of test equipment will also be staged at the Mechanics' Institute, Bradford, on March 31st and April 1st between 2.15 and 6.30. "Measurtest" instruments, including the new portable receiver tester, will be demonstrated.

Plessey International, Ltd., has been formed by the Plessey Co., of Ilford, with a view to establishing factories in other countries, with the exception of Eire where a new company, to be known as **Communication Components, Ltd.**, is being established in Dublin.

R.C.E.E.A.—The Council of the Radio Communication and Electronic Engineering Association, which is one of the four constitutory bodies of the Radio Industry Council, has elected L. T. Hinton, B.Sc., (S.T.C.), and M. M. Macqueen (G.E.C.) chairman and vice-chairman, respectively, for the current year.

Wire Recorders.—A company has been formed to combine the activities of Boosey and Hawkes and Associated Electronic Engineers in the field of magnetic wire recording. The new company—Wirek (Electronics), Ltd., 9/10, Dalston Gardens, Stanmore, Middlesex—has in production eleven different types of recording equipment ranging from medium-fidelity speech recorders for lectures, conferences, etc., to high-fidelity machines, with overall characteristics level to ± 3 db from 50 to 9,000 c/s. The company is also in a position to supply the following components for experimenters: recording heads, wire, spools, screened bias oscillator coils and input transformers. Circuit diagrams will also be available.

MEETINGS**Institution of Electrical Engineers**

Radio Section.—Discussion on "Future Trends in the Design of Receiving Aerials," on April 13th, at Savoy Place, London, W.C.2, at 5.30. Opener E. M. Lee, B.Sc.

Cambridge Radio Group.—"Television Camera Tubes," by F. H. Townsend, on April 6th, at the Cambridge-shire Technical College, at 6.

North-Eastern Radio and Measurements Group.—Annual general meeting followed by discussion and demonstration on "The Influence of Frequency Response Bandwidth on the Appreciation of Electrically Reproduced Speech and Music," on April 12th, at King's College, Newcastle-on-Tyne, at 6.15. Opener, G. A. Hickling.

North - Western Radio Group.—"Pulse Communication," by D. Cooke, B.A., Z. Jelonek, A. J. Oxford, B.Sc., and E. Fitch, B.Sc., on April 7th, at the Engineers' Club, Albert Square, Manchester, at 6.30.

Scottish Centre.—"The Cavity Magnetron," by H. A. H. Boot, Ph.D., and J. T. Randall, D.Sc., F.R.S., on April 14th, at the Heriot-Watt College, Edinburgh, at 6.

South Midland Radio Group.—"Investigation and Forecasting of Ionospheric Conditions," by Sir Edward Appleton, G.B.E., K.C.B., M.A., D.Sc., F.R.S., on April 27th, at the James Watt Memorial Institute, Great Charles Street, Birmingham, at 7.

Southern Centre.—Faraday Lecture on "Electricity and Everyman," by P. Dunsheath, C.B.E., M.A., D.Sc. (Eng.), on April 8th, at the Guildhall, Southampton, at 7.30.

British Institution of Radio Engineers
London Section.—"High Fidelity Recording and Reproduction," by W. S. Barrell and G. F. Dutton, Ph.D., D.I.C., on April 8th, at the E.M.I. Studios, 3, Abbey Road, St. John's Wood, London, N.W.8, at 6.

Merseyside Section.—"The Physical Applications of Micro-Waves," by J. B. Birks, B.A., on March 31st, at 6.45.

"Some Aspects of Moderate Precision Temperature Control in Communication Engineering," by M. P. Johnson, B.A.Sc., E.E., on April 14th, at 6.45.

Both these meetings will be held in the Lecture Room, Liverpool Engineering Society, 9, The Temple, 24, Dale Street, Liverpool, 2.

North - Western Section.—"Link-Coupled I.F. Circuits Applied to Car Radio Receivers," by R. D. Trigg, on April 8th, at the College of Technology (Reynolds Hall), Sackville Street, Manchester, at 6.45.

Scottish Section.—"The Physical Applications of Micro-Waves," by J. B. Birks, B.A., on April 21st, at the Institution of Engineers and Shipbuilders in Scotland, Elmbank Crescent, Glasgow, C.2, at 6.45.

North-Eastern Section.—"The Pulse Signal," by Professor M. G. Say, Ph.D., M.Sc., on April 14th, at Neville Hall, Westgate Road, Newcastle-on-Tyne, at 6.

British Sound Recording Association

London Meetings.—The meeting on March 25th, at which W. S. Barrell, B.Sc., will read a paper on "High Quality Disc Recording," will be held at E.M.I. Studios, 3, Abbey Road, St. John's Wood, London, N.W.8, at 7.15, and not at the Royal Society of Arts as stated last month.

"Quality Factors in Film Recording," by B. C. Sewell, on April 23rd, at the Royal Society of Arts, John Adam Street, Adelphi, Strand, London, W.C.2, at 7.

Electrical Trades Union

London Meeting.—Open discussion on "Tone Control Circuits," on April 22nd, in the Oak Room, Kingsway Hall, Kingsway, London, W.C.1, at 7.

Junior Institution of Engineers

"The Manufacture of Gramophone Records," by H. W. Bowen, O.B.E., on April 16th at the Institution, 39, Victoria Street, London, S.W.1, at 6.30.

Radio Society of Great Britain

"Radio Signals from the Sun," by M. A. Ryle, M.A., on April 9th at the I.E.E., Savoy Place, London, W.C.2, at 6.30.

Society of Relay Engineers

"Negative Feedback and Direct Coupling as applied to A.B.2 Amplifiers," by L. F. Odell, on April 27th, at the Royal Society of Arts, John Adam Street, Adelphi, Strand, London, W.C.2, at 2.15.

Unbiased

By FREE GRID

Retrogress in Receiver Design

THE Moguls of the wireless industry who are responsible for the receivers offered to us members of the listening public—who indirectly pay the rent of the marble halls in which they dwell—seem, in certain respects, to be altogether out of touch with the common man and his radio needs. They seem to imagine that we all dwell in baronial halls, like themselves, each member of the family occupying a separate wing to which he can retire and listen to the programme of his choice without interfering with that of the others. It never seems to occur to them that—perish the thought—some of us on occasion have such perverted tastes as to like certain items in the third programme and are debarred this enjoyment because we cannot very well start up a set in opposition to the one churning out the melancholy cadences of some cacophonous crooner in the light programme. The resulting noise would be more horrible than that of the crooner.

The only solution is for third-programme addicts to listen with high-quality headphones, but how many receivers are there with provision for connecting headphones? None so far as I am aware and this, in spite of all the talk about the necessity of a second receiver in the home. The reason, as I have already mentioned, is the baronial hall complex of the set manufacturers who imagine that we can



Leg-entangling paraphernalia.

retire with our second set and listen to the third programme in the chilly and ghost-ridden East Wing of the castle.

Reluctant as I am to praise manufacturers, I must do so in the case of those turning out radio-gramophones with a flush top panel and a

deeply recessed lid. This enables us to sweep all the dust on to the floor and is a great improvement on the old dust-trap type. It was impossible to clean the latter except by fitting together the hose and other leg-entangling paraphernalia of a vacuum cleaner. But why not go a step further and make the lid domed so that a woman cannot stand an aspidistra on the top of it, which has to be hurled to the ground every time you want to play a record. Radio manufacturers ought to realize that the broad lid of the conventionally designed radio-gramophone is an open invitation to women to stick things on it; probably, however, most of them keep their wives in a separate wing of the baronial hall and so cannot be expected to be acquainted with the conditions of family life which have to be endured by the common man.

"I Done It"

IT is never wise to meddle in matters which you don't properly understand, as an old countryman once told me when I poked my umbrella, with disastrous results, into a wasps' nest which he was pointing out to me. By my blundering reference in the February issue to an American claim to locate paranormal entities (ghosts to you) by means of radar I certainly got more than I bargained for in the way of helpers willing and anxious to accompany me to the site of Borley Rectory. So overwhelming has been the response that I have had to call the whole thing off, as no self-respecting ghost would do other than imitate Achilles and sulk in his tent, before such a multitude. I must, however, take this opportunity of thanking my correspondents, for it would be quite impossible to reply individually to them, as Mr. Isaacs refuses to direct the necessary number of stenographers to help me.

Fortunately, however, my would-be helpers needn't be disappointed as one correspondent has very kindly sent me a cutting from the *Suffolk and Essex Free Press* of February 5th from which it would appear that the Borley manifestations have moved themselves three miles to "The Bull" at Long Melford. This is certainly a very sensible thing to do, as one could hardly think of a more comfortable

place in which to investigate such matters.

I certainly intend to go to "The Bull," but on my own for reasons already explained. I do hope, how-



Disastrous results

ever, that some of you will find your way there. Should you see anything which causes you to feel that spirits of a more tangible kind would revive drooping morale, you can charge it up to the Editor's account, that is if the manager is naïve enough to think he can get the money out of him.

Among my correspondents I want particularly to mention an earnest Scotsman who casts some doubt on the truth of some of Queen Elizabeth's nocturnal activities to which I referred in May, 1946. I can only conclude that bitter memories of the disgraceful way in which Elizabeth treated Scotland's Queen at Fotheringay Castle must have so roused his national feelings as to cloud his better judgment. Another correspondent tells me that Mr. Harry Price, the psychic investigator, has stated that my remarks about nobody having had the gumption to adopt modern scientific methods is without foundation, and for this statement I sincerely apologize.

I am rather afraid that I annoyed the poltergeists, as they somehow or other made me appear to write psycheurlator (presumably a ghost worshipper) when I thought I wrote psycheuretor (a ghost hunter); as if the verb *ἐυρισκω* weren't irregular enough already. In any case, as one very learned psychist tells me, it actually isn't the "Psyche" at all but the "Phantasma" which is responsible for all this sort of thing; that being so, I can't think why he continues to call himself a psychist instead of a phantasmist.

Atlantic City

Summary of the Findings of the International Telecommunication Conferences

WE have now had an opportunity of studying the "Final Acts" of last year's Atlantic City International Telecommunication and Radio Conferences, to which a brief reference was made in last month's Editorial. It is proposed to outline in this article some of the major changes introduced in the regulations and findings in so far as they differ from those of the last conference (Cairo, 1938).

Before dealing with these, however, it is worth looking into the constitution of the conferences and the objects of each of the four which, together, lasted twenty weeks. As mentioned last month, the volume embodying the "Final Acts" is divided into three sections: International Telecommunication Convention; Radio Regulations; and Recommendations adopted by the Radio Conference. The plenipotentiaries of the seventy-eight participating countries signed the Convention on October 2nd. It is effective from January 1st, 1949. Its forty-nine articles cover the composition, functions and structure of the International Telecommunications Union, including the establishment of the International Frequency Registration Board, and general and specific provisions relating to telecommunications and radio.

Conference Objectives

The four conferences, the first of which opened in Atlantic City on May 15th last year, were: the *Radio Conference*, to revise the radio-communication regulations and replan the frequency allocation; the *Plenipotentiary Conference*, to revise the international telecommunication convention; the *High-Frequency Broadcasting Conference*, originally planned to re-allocate frequencies for long-distance broadcasting stations, but actually restricted to preparatory work for conferences to be held in Mexico City from October 22nd this year; and a

preliminary *European Broadcasting Conference*, which, although not originally scheduled, was decided upon in view of the number of European delegates present.

The British delegation totalled nearly 30, and included representatives of the G.P.O., the three Fighting Services, B.B.C., British Joint Communications Board responsible for Services communications, the Foreign Office and scientific advisers from the Ministries. The G.P.O. representatives included A. J. A. Gracie, assistant secretary, Overseas Telecommunications Dept.; S. Horrox, principal, Telecommunications Dept.; Col. A. H. Read, inspector of wireless telegraphy; and A. H. Mumford, staff engineer, Radio Development Branch. The B.B.C. was represented by Sir Noel Ashbridge, director of technical services, and L. W. Hayes, head of overseas engineering and information department. The leader of the delegation was Sir Stanley Angwin.

To turn now to the actual findings of the conferences.

Comparing the Atlantic City and Cairo Regulations, from the point of view of frequency allocation, a writer in the January issue of *The Post Office Electrical Engineers' Journal*, states: "the changes that have been introduced fall broadly into three categories, namely:—

"(a) The formulation of service definitions to cover new types of service;

"(b) the introduction of new regional boundaries for allocation purposes;

"(c) changes in the frequency allocation table itself."

Summarizing the first of these, the writer states that: "in addition to the services to which bands were allocated under the Cairo Regulations, specific provision is now made for radio navigation systems, for radio aids to meteorology, and for the transmission of standard frequencies of high accuracy. In addition, cer-

tain limited bands have been designated for industrial, scientific and medical equipment. . . ." In the summary of allocations published in November (p. 439) one frequency assigned to I.S. and M. was omitted; the complete list is 13.56, 27.12, 40.68, 2450 and 5850 Mc/s.

New Regions

In the Cairo Regulations the world was divided into the "European Region" and "Other Regions," but is now split into three for the purpose of frequency allocations; the boundaries of the regions are defined as:—

Region 1 is limited on the West by line B (see accompanying map) and on the East by line A, except that it includes that part of Turkey and the U.S.S.R. outside this limit, the territory of the Mongolian Republic and the area to the North of the U.S.S.R. between lines A and C. It does not, however, include any part of Iran.

Region 2 includes the area between line B in the East and C in the West.

Region 3 is limited on the East by C and the West by A but excludes Turkey, the U.S.S.R. and Mongolia, which are incorporated in Region 1. Iran is included in this region.

In our earlier reference to frequencies allocated at Atlantic City we erroneously implied that Region 1 was the "European Region." This is not so. Within Region 1 is the "European Area," the boundaries of which are: West, line B, East, the meridian 40° E, and South, the parallel 30° N. The parts of Arabia and Saudi-Arabia coming within these boundaries are excluded from the "Area."

Under the Cairo Regulations the "European Region" was, as stated above, one of the fundamental geographical areas for allocating frequencies to all services throughout the spectrum 10 kc/s to 200 Mc/s, whereas the

European Area is now included only for the purpose of controlling the frequencies of long- and medium-wave broadcasting stations in that area.

Tropical Broadcasting

It has also been found necessary to re-define and extend the Tropical Zone for the allocation of frequencies for tropical broadcasting—defined as “broadcasting for international use”—in countries within this zone which now girdles the earth. As will be seen from the map, it lies between the tropics of Cancer and Capricorn with extensions in certain areas.

The bands allocated for broadcasting in the Tropical Zone are:—

- 2.3—2.498 Mc/s
- 3.2—3.4
- 4.75—4.995
- 5.005—5.06

The upper limits of the 2-Mc/s

casting is for use by broadcasting stations generally.

The writer in the *P.O.E.E.J.* points out that the principal changes in frequency allocation involve increases for aeronautical and broadcasting services and amateurs with a reduction of some 10 per cent in the allocations for maritime and fixed services; the reduction—almost to elimination—of shared bands; and the use of harmonic relationship for the ship-to-shore sections of the maritime mobile bands.

The table of frequency allocations, which now extends from 10 kc/s to 10,500 Mc/s, has been accepted without reservation by all the countries represented. This covers block allocations to the various services, and it now remains for agreement to be reached regarding allocations for individual countries in the broad-

pared by a committee consisting of representatives of Belgium, France, Great Britain, Holland, Sweden, Switzerland, the U.S.S.R. and Yugoslavia. This plan is being prepared in readiness for the European Broadcasting Conference to be held in Copenhagen in July.

Frequency Registration

It has already been stressed in *Wireless World* that one of the most important outcomes of the Atlantic City conferences is the decision to set up an International Frequency Registration Board whose task it will be to examine all notifications of the proposed use of frequencies, and if approved, they will be included in the Master International Frequency Register. A list of registered frequencies will be published from time to time by the

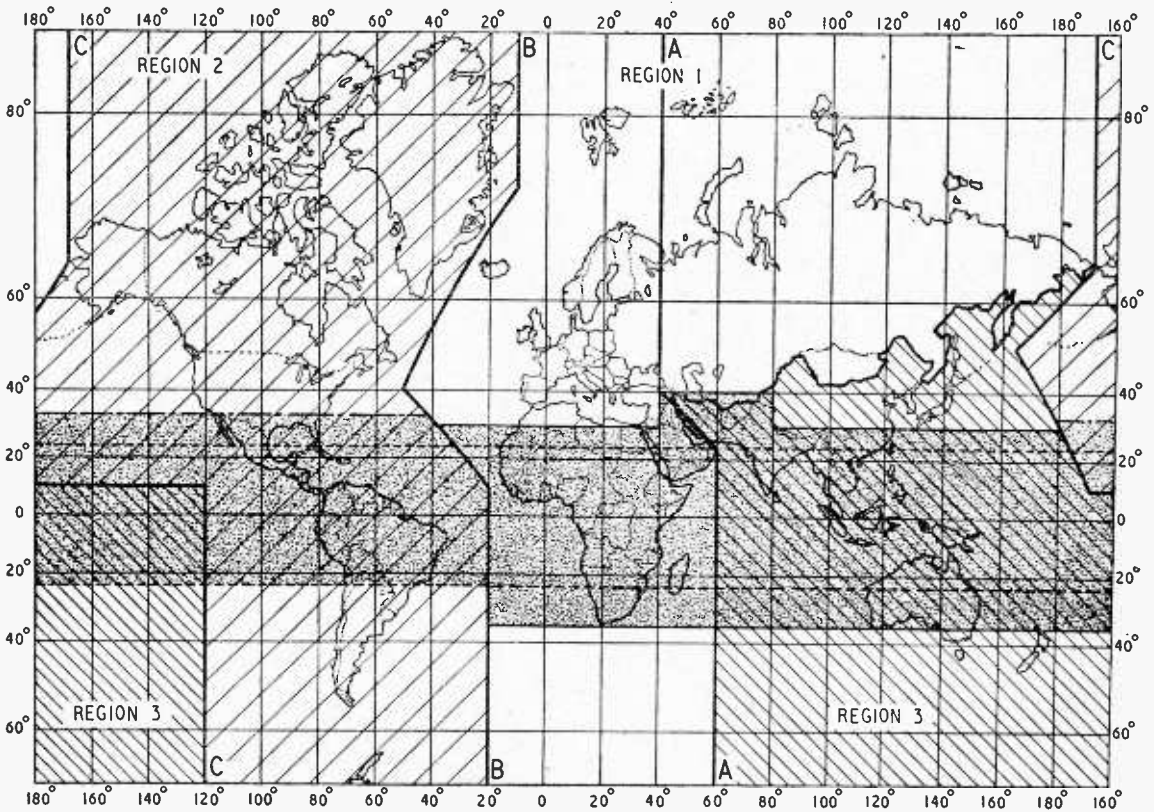

The three Regions into which the world is divided for the purpose of frequency allocation are shown on this map. The Tropical Zone which now girdles the earth, is shaded.

band are reduced to 2.495 in Regions 2 and 3. The band 3.95-4.0 Mc/s included in our previous list as allocated for tropical broad-

casting bands. So far as Europe is concerned, a preliminary plan for the long- and medium-wave broadcasting bands is being pre-

Bureau of the International Telecommunication Union.

The I.F.R.B. is composed for the first five years of representa-

Atlantic City—

tives of each of the following countries, who were elected by secret ballot: Argentina, Australia, China, Cuba, Czechoslovakia, France, Great Britain, India, South Africa, U.S.A. and U.S.S.R. By a division of the world's surface into four, the conference ensured an even distribution of membership. The same procedure was adopted for the election of members to the Board of the I.T.U. The U.K. representative on the I.F.R.B. is A. J. A. Gracie (see this month's "World of Wireless").

The preparatory draft of an International Frequency List covering the assignments to fixed service stations, tropical broadcasting transmitters and mobile land stations, within the band 10kc/s to 30Mc/s, is being undertaken by the Provisional Frequency Board. This consists of members of the I.F.R.B. and representatives of countries desirous of participating in this work. The P.F.B. aims at completing the draft by November 15th. It will be studied at a special conference to be called in March next year.

It is recommended that the provisions of the International Frequency List become effective by September 1st, 1949.

New Definitions

Among the definitions laid down in the first chapter of the Radio Regulations are some which were unheard of when the Cairo regulations were drawn up. They include "facsimile"; defined as a system of telecommunication for the transmission of fixed images with a view to their reception in permanent form. The exclusion of "phototelegraphy" points to the general use of "facsimile" for all systems for the transmission of "fixed" images as opposed to "transient" images of fixed or moving objects which is, of course, defined as television. Radiolocation is included, and is defined as "determination of a position or of a direction by means of the constant velocity or rectilinear propagation properties of Hertzian waves." The employment of radiolocation solely for the purpose of "the determination of position or direction or for obstruction warning in navigation"

is termed "radionavigation."

Radar is defined as a "radiolocation system where transmission and reception are carried out at the same location, and which utilizes the reflecting [primary radar] or retransmitting [secondary radar] properties of objects in order to determine their position."

Transmissions Classified

The revised classification of the various types of transmission includes the three types of modulation; amplitude, frequency (or phase) and pulse, the symbols for which are A, F and P, respectively.

The digits used to define the type of transmission have been increased. They are now: 0, unmodulated; 1, keyed C.W.; 2, keyed audio-frequency modulated waves (M.C.W., I.C.W.); 3, telephony; 4, facsimile; 5, television; and 9, composite transmissions.

The classification of transmissions includes, in addition to the types of modulation and transmission, a third symbol denoting supplementary characteristics. They are:—

- a, single side-band, reduced carrier (double side-band, full carrier, no symbol).
- b, two independent side-bands, reduced carrier.
- c, other emissions, reduced carrier.
- d, pulse, amplitude modulated.
- e, pulse, width modulated.
- f, pulse, phase (or position) modulated.
- B, damped waves.

The bandwidth occupied by the transmission is indicated, where necessary, by a prefixed number giving the width in kc/s.

As an example of this classification, A.M. telephony (3,000 c/s max. modulation) on single side-band with reduced carrier is designated 3A3a.

It is regrettable that whilst

classifying frequency bands a break-away was not made from the use of the superlatives "very," "ultra," "super," etc. The new classification which, so far as wavelength is concerned, follows the metric system employed in the British Standards Glossary (B.S.204) except that the range is extended down to 0.001 metres which are classified as millimetric waves. In the frequency classification this band is designated "extremely high," so that we now have V.L.F., L.F., M.F., V.H.F., U.H.F., S.H.F., and E.H.F.

International Call-signs

Considerable changes have been made in the international list of call signs consequent upon the geographical changes as a result of the war. Germany's "D" allocation is to be divided between Germany, Belgian Congo, Bielorussia and the Philippines. Japan's "E" will in future be used by the U.S.S.R. and its "J" is to be shared with Mongolia and Norway. The previous list of calls began at CAA and ended at ZZZ. The new list includes "A" and "B" allocations and terminates with a series using a numeral and two letters. The first of these is 2AA-2ZZ and the series continues to 4WZ.

The "Q" code has been amended and now includes a number of new abbreviations, most of which relate to movements of ships and aircraft, search and distress, meteorology and D.F.

It has not been possible within the limitations of this article to deal with the "Final Acts" *in extenso*, and it is therefore hoped to give further details of specific items in future issues.

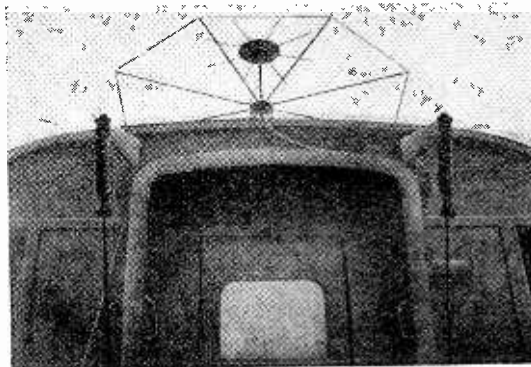

RAILWAY RADIO. Successful radio-telephone transmissions between a train on the Rome-Tivoli line and the chief railway office in Rome were conducted towards the end of last year. F.M. on 2-3 metres was employed. The aerial mounted on the roof of one of the coaches is shown here.

New Books

Electronic Circuits and Tubes. By the War Training Staff of the Cruft Laboratory, Harvard University. Pp. 948 + xxiv, with 759 illustrations. McGraw Hill Publishing Co., Ltd., Aldwych House, London, W.C.2. Price 45s.

IT is stated in the foreword that "This book has developed from the lecture notes of a special wartime training course given in the Graduate School of Engineering, Harvard University," that "the material of the course was fundamental in nature and not exclusively applicable to wartime training," and that "it is hoped that the text will be as valuable for peacetime courses as it was successful in its intended purpose." "A knowledge of mathematics through calculus, and of electricity and magnetism is assumed."

Starting with Alternating Current Theory, the book covers Circuit Response, Circuit Elements (and their measurement), Networks and Impedance Matching, Transients, Coupled Circuits, Filters, Fourier Analysis, Electron Emission and the Diode, Multi-element Tubes, Cathode Ray Tubes, Amplifiers, Class A and Class B, Power Tubes, Oscillators, Gas-Filled Tubes, Rectifiers and Power Supplies, Signal Analysis, Principles and Methods of Modulation, Detection, Test Instruments, Radio Receivers and Tuning Circuits.

A number of different authors are responsible for different chapters and doubtless it is because of this that there is some patchiness in treatment. Some chapters are extremely detailed and very thorough, others are much more elementary and of a rather superficial character. The chapter on coupled circuits, for instance, is extremely good and in addition to the usual resonance curves there are photographs of space models showing the response three-dimensionally. Detection is also well done and the importance of keeping a high ratio of A.C./D.C. loads is well brought out by oscillograms of the output waveform.

The treatment of power amplifiers is good, including the class C types so widely used in transmitters. The section on frequency multipliers, however, is very disappointing; it comprises only 1½ pages. In view of their widespread use it is to be regretted that the authors did not see fit to treat them adequately.

Another important subject which is dealt with in only a superficial fashion is the superheterodyne receiver. Frequency-changers occupy

some nine pages of largely descriptive material. There is no mention of oscillator tracking methods nor of the mechanism of production of spurious responses, apart from the image response, which is only one among many. Later in this same chapter under the heading "Interference" (two pages) there are brief references to more of them, but there is little indication of their magnitude or practical importance, and little is said about methods of avoiding or reducing them.

The chapters on measurements and test instruments are very elementary and well below the general standard of the book. Common methods are briefly described, but little or nothing is said about their accuracy.

Rectifiers and power supplies are unusually fully treated and the emphasis is on apparatus of fairly high power. This high-power stress applies also in large measure to the treatment of oscillators and amplifiers. It is noticeable throughout the book that the high-power aspects are given more attention than the low-power, and this does make the book of greater value to those interested in transmission than to those primarily concerned with reception.

On this latter side, another omission is any adequate treatment of receiver noise. Even more surprising is the fact that wideband amplifiers, in the usual sense of the term, are not mentioned at all. A wideband amplifier is defined as an amplifier in which the bandwidth is large compared with the mean frequency and is applied to A.F. and V.F. amplifiers. No reference is made to wideband R.F. amplifiers, such as those in television and radar, where the bandwidth is an appreciable fraction of, but is not large compared with, the mean frequency. The problems involved in these are in some ways more difficult of solution than those in V.F. amplifiers and demand special methods, such as stagger tuning, which are not treated.

A.F. transformers are dealt with very inadequately, and so are valves with more than three electrodes. Diodes and triodes are very well treated, but valves with more electrodes are dismissed in some seven pages.

Chapters are divided into numbered sections and the figure numbering starts afresh in each section and is prefixed by the section number but not the chapter number, so that there are many illustrations with the same number. This incon-

The following figures are the pass figures on final test for Model QA12/P AMPLIFIER



FREQUENCY RANGE
± 0.3 db 20 - 20,000 c.p.s.
SENSITIVITY
1.5 millivolts for full output
(without boosts)
15 millivolts for full output
(with boost.)
BASS CONTROL RANGE
- 12 db to + 16 db at 30 c.p.s.
relative to 600 c.p.s.
TREBLE CONTROL RANGE
- 30 db to + 18 db at 15,000
c.p.s. relative to 600 c.p.s.
DISTORTION COEFFICIENT
(up to 12 watts output)
2nd Harmonic < 0.2%
3rd Harmonic < 0.3%
Higher order < 0.03%
Total < 0.4%
BACKGROUND NOISE
better than - 66 db at full gain
DAMPING FACTOR 12
INPUT IMPEDANCE
1.5 megohms
SOURCE IMPEDANCE
Up to 50,000 ohms
OUTPUT IMPEDANCE
7 and 15 ohms

226*

 **ACOUSTICAL**

ACOUSTICAL MANUFACTURING
CO., LTD., HUNTINGDON

TEL: 361

New Books—

venient system has led to the omission of the proper Fig. 4.1 from Chapter II (p. 27) and to the repetition, in its place, of Fig. 4.1 from Chapter I (p. 7). It is surprising that this has not occurred more often! In Fig. 7.1, p. 14, a blocking capacitor has been omitted and the diagram shows a short-circuit on the H.T. supply. In Fig. 13.7, p. 518, of a transitron oscillator, the grid leak to G_2 has been omitted; as shown, the circuit cannot work. The use of a comma, instead of a product sign, in the last equation on p. 95 makes it meaningless.

These are minor points in a book of which some two-thirds is excellent and deserves the highest praise. One-third of it is disappointing, not because of errors, but because of a superficiality of treatment.

W. T. C.

Theory and Application of Microwaves. By A. B. Bronwell and R. E. Beam. Pp. 470+vii with numerous illustrations. McGraw-Hill Publishing Company, Aldwych House, London, W.C.2. Price 36s in U.K.

THIS book is not an elementary text and is presumably intended for the reader who has already had considerable acquaintance with electromagnetic theory. In the reviewer's opinion there is a tendency, which is to be deplored, for writers of books on new fields of application of electromagnetic theory to devote far too much space to needless recapitulation of standard and basic work, already dealt with admirably. Whilst there is not a great deal to quarrel with in the actual treatment of the matters included in this book, in view of the title it may be said that it contains much that is superfluous, and also unfortunately, insufficient information relating to microwave technique. The authors excuse the omission of a discussion of some aspects of radio circuit theory on the grounds that "there are a number of excellent textbooks dealing with such matters." One is inclined to ask, therefore, why they have not shown the same sense of discrimination with respect to the rest of the material.

The general process of development is as follows. After several introductory sections on the behaviour of charges in electric fields; current, power and energy relationships, and the physical basis of equivalent circuits, we come to three chapters devoted to a discussion of oscillators. These include a treatment of transit-time oscillators in general with particular reference to the klystron and the magnetron.

We then have three further chapters on various aspects of transmission lines, both from the theoretical and experimental point of view. Transmitting and receiving systems are considered in Chapter 11, and pulsed systems, particularly radar systems, briefly in Chapter 12.

The chapters on Maxwell's equations and the solution of electromagnetic-field problems might well have been condensed into a mere introduction to the subject of waveguides as considered in Chapter 16. This chapter contains a satisfactory and quite concise treatment of the phenomena associated with propagation in waveguides. The last five chapters are concerned with the applications of waveguides and resonators, linear antennae and arrays, the impedance of antennae, and finally other radiating systems such as the biconical antenna and horn radiators.

There are one or two errors which must be pointed out. One page 427 the figure which is supposed to indicate the nature of the current distribution in a centre-fed aerial relates in fact to an end-fed antenna.

Then, on page 216, the equivalent absorption area of an ideal short doublet receiver is actually attributed to a half-wavelength dipole.

There is a quite inadequate section on propagation characteristics. This fundamental matter is here dismissed in two or three short paragraphs. In Chapter 10 there are some references to impedance and power measurement at microwave frequencies, though not in any detail, and this is a further example of a matter on which the authors could profitably have expanded the treatment.

The book is well produced, and liberally illustrated. The authors have justified their claim that: "throughout the engineering point of view has been stressed, and that, wherever possible, the analytical results have been expressed in a form convenient for engineering use." A good feature is the number of illustrative examples included in the text; there is also a wide selection of problems suitable for students.

J. A. S.

Radio Engineering (Volume 1). By E. K. Sandeman, Ph.D., M.I.E.E. Pp. 775+xxiv. Chapman and Hall, Ltd., 37, Essex Street, London, W.C.2. Price 45s.

THIS work claims to be "a textbook for beginners" and "a reference book for experienced engineers." According to its author, it "assumes complete ignorance on the part of the reader and develops the required terminology as it goes

along." And "The reader should have a working knowledge of elementary algebra, and should preferably understand logarithms. The necessary elements of trigonometry are stated, while complex algebra is developed from first principles. With these qualifications, it is true to say that in the main body of the book information is imparted in a logical sequence so that a novice who conscientiously reads the book from the beginning always finds the subject matter within his grasp."

It is doubtful whether anybody, working on this basis, could successfully write for novices and experienced engineers at the same time. Certainly the author has not succeeded. What he has done is to produce a notable and important work on broadcast transmitters, with particular reference to B.B.C. practice. This volume has 775 pages, and there is another volume to come. The fact that subject matter which is irrelevant to broadcast transmitters is almost entirely left out means that there is room for a quite exceptionally thorough treatment of everything that does concern broadcast transmitters. This treatment is based on the unsurpassed experience of the B.B.C. in that field; and, as the author acknowledges in detail, his work has had the full co-operation and authority of the B.B.C. technical staff. It provides a vast amount of data on the practical design, operation and maintenance of fixed transmitters for broadcasting sound on carrier frequencies between 200 and 20,000 kc/s. The basic principles, especially impedance, are treated very thoroughly, and can be applied more generally. Diagrams and charts are consistently clear, and the text is well printed and comparatively free from errors.

As a textbook for beginners, it cannot be so highly recommended. The author does not seem to have been able to look at his writing through the eyes and mind of someone reading it for the first time. He persistently uses technical terms, and—worse still—ordinary words used in a technical sense, long before he defines or explains them. Many important terms and concepts are explained casually somewhere in a sub-section devoted mainly to something else. The explanations, when they do come, are often expressed in the language of one who knows it already. A beginner, stumbling over the first occurrence of a mysterious word, is unlikely to find what he wants in the Index, or may be referred by it to the unpublished Vol. 2. In the absence of any guidance as to what is for him and what is for the experienced engineer, he repeatedly finds himself

up against illustrations drawn from techniques which he, if he really started in complete ignorance, must find completely beyond him. From the very start he is faced with such terms as "normal" (meaning perpendicular), "sense" (meaning polarity or sign), "bridge" (the network), "shunt" (parallel), "programme" (meaning alternating currents corresponding to sounds in a broadcasting studio), "bandwidth," "C.C.I.," "C.C.I.R.," "quarter-wave choke," "class C.," "Miller capacity," "balanced" (to earth). If at the start he knows nothing of the nature of electromagnetic waves, so much the worse for him; he will not be enlightened, unless he persists as far as p. 669, where a few casual lines about polarization (under "Short-Wave Transmitting Aerials"!) might give him a clue.

It is difficult to see a "logical sequence" in the order of Chaps. III, IV and V, devoted respectively to the sine wave and vectors, D.C., and A.C. Difficult sections of text are often placed with no clue to

their significance or why one ought to make a special effort to learn them.

Although the author admits that to him there is no point in reading mathematical descriptions (whether one understands them or not) he imposes many such descriptions on his readers. And he does not always keep faith with them by explaining any mathematics beyond elementary algebra, but slips in a bit of calculus here and there without warning. At other times he stands by strict rule of thumb and refuses to say *why* Litz must not be used above 2Mc/s or sharp points are more likely to provoke discharge than rounded surfaces. But generally a proper use of mathematics for practical engineering is well maintained.

If a restrictive sub-title is added, and the invitations to the ignorant are expunged, most of the foregoing criticisms lose most of their force. With these mental adjustments this book can be more readily welcomed as a valuable contribution to the literature. M. G. S.

LETTERS TO THE EDITOR

V.H.F. for Quality + Locating Clandestine Stations + Magnetophon Tape

Frequency Modulation

THE almost constant appearance, in advertisements, of the words "high fidelity," lead me to surmise that there must be, even now, a considerable demand for such reproduction. This demand cannot be met, in spite of Mr. Cazaly's assertion in your March issue, while the medium waveband is used for propagation. Technicians appear to be unanimous in their opinion that a move to higher frequencies is necessary and inevitable. Although such change will obviously be delayed by present economic circumstances, the necessary experimental and pioneering work should be carried out as rapidly as possible.

S. G. BARRELL.

Ashtead, Surrey.

Symbol of Inconstancy ?

I ACCEPT D. K. McCleery's challenge (your March issue).

He has failed to distinguish between the symbol for *variability* (a "filled-in" arrowhead with curved outlines) and that for

direction an open arrowhead with straight sides. The symbol should be like this in a normal year:



and this in a leap year:



L. BAINBRIDGE-BELL.
Haslemere.

"Micro-waves and Waveguides"

IN your March issue there is a review of my recent book which I feel cannot be allowed to pass without comment. The general opinion expressed by the reviewer differs so markedly from the assessment of the many engineers who have read the book and subsequently sent me appreciative remarks that it is clear his verdict cannot be regarded as a representative one.

The development of the characteristics of waveguide modes on

And now the STANDARD RACK

2506

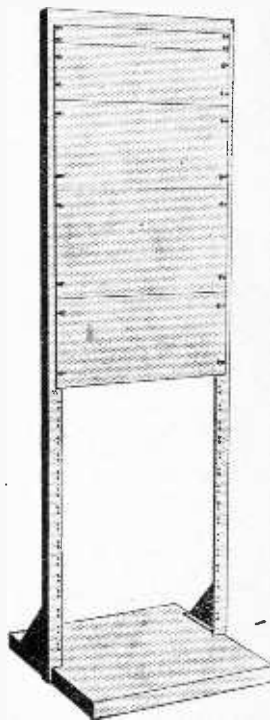

Latest edition to the Imhof range of cases is the new Standard Rack and Panel assembly. Of heavy gauge mild steel angle, it is strongly constructed with welded corners, and finished in grey stove enamel. Standard 19" Rack panels of $\frac{1}{8}$ " thick mild steel plate are available in four sizes:—1 $\frac{1}{2}$ ", 5 $\frac{1}{2}$ ", 8 $\frac{1}{2}$ " and 10 $\frac{1}{2}$ " deep, also finished in grey stove enamel.

Prices:—
Standard Rack from 56" high, £4 15s. 0d. each
Panels 19" x 10 $\frac{1}{2}$ " 11s. 3d. "
" 19" x 8 $\frac{1}{2}$ " 8s. 9d. "
" 19" x 5 $\frac{1}{2}$ " 5s. 7d. "
" 19" x 1 $\frac{1}{2}$ " 3s. 2d. "
Plated chassis with associated mounting brackets 15s. per set.



PRECISION BUILT INSTRUMENT CASES
112-116, NEW OXFORD STREET,
LONDON, W.C.1

Telephone: MUSEum 5944

Letters to the Editor—

the basis of what the reviewer calls a thin analogy with propagation along parallel wire transmission lines is now recognized as a most valuable means of approach to this subject, and in fact has presented to the engineer for the first time that physical picture of the mechanism involved for which he has been searching so long. Obviously such an approach has limitations, but provided that these are kept in mind they do not detract from the value of the device.

In restricting the mathematical analysis to wave modes of particular engineering significance the treatment becomes more objective and attention is focused on specific problems of importance. In this way much more is gained than lost since a wider discussion would not really help most engineers, and would be more difficult to follow.

An examination of the problem of attenuation in general is beyond the scope of this book, but a typical case was deliberately chosen for simplification in such a way as to enable the change to be followed from normal wave propagation to evanescent conditions.

The reviewer does not appear to have any real conception of what this book sets out to achieve, nor the least understanding of the essential ideas behind the chosen form of presentation.

H. M. BARLOW.

London, W.C.1.

Clandestine Radio Transmissions

THE article published in your January issue about clandestine radio reception in Holland was of especial interest to me. During my work in an Intelligence Section in that country I had some opportunity of learning how such listening was often carried on.

It was, indeed, a source of much annoyance to the Germans; but nothing like the clandestine radio transmissions, which were carried on by the Resistance movements through all the occupation years. There were a number of these small (and usually highly mobile) stations throughout Holland, Belgium, and France, and they by no means all came to an untimely end. It is *not* easy to locate an

A.M. station with pin-point accuracy by purely D.F. means, even when these transmissions always take place on the same frequency—and often at pre-advertised times. In at least one case two and a half years were insufficient for German investigators to track down a transmitter operating more or less daily for long periods within a small area of Central Holland.

C. D. SIMMONDS.

Maryport, Cumberland.

Magnetic Recording

MR. L. G. WOOLLETT seems to suggest in your March issue that alternative widths of magnetic tape were standardized in Germany for use with the Magnetophon system, one of 0.254 inch, and the other of 1 cm. So far as we are aware, the only standard width was 6.5 mm. (= 0.256 in). We do not know what manufacturing tolerances were permitted.

The width adopted by British manufacturers at the meeting convened by the B.B.C. in May, 1947, was 0.245 in, with a tolerance of ± 0.005 in, the intention being to standardize on a round figure in British units ($\frac{1}{4}$ in) for the maximum tape width. The width of the tape guides was not specified at the meeting, but it is the intention to make these wide enough to accept tape made to the German standards, the whole background to the discussion being a desire on the part of the B.B.C. to ensure that equipment manufactured in Britain should be capable of playing recordings made with tape or machines using the German standards.

It may be appropriate here to say that attempts are about to be made to obtain agreement in a wider field on the standardization of those parameters of the system which governs the interchangeability of tape recordings.

H. BISHOP,

Chief Engineer, B.B.C.

Manufacturers' Products**Five-band Coil Turret**

THE Denco coil turret Type CT6 is designed for use in a broadcast superhet receiver having a

triode-hexode frequency changer as the first valve. It includes coils for five wavebands giving a continuous coverage of from 30Mc/s to 530kc/s, and a long-wave range of 400 to 150kc/s. The oscillator padders are for an I.F. of 465kc/s.

In the form shown, the turret includes a two-gang condenser and a large rectangular black-glass dial with five clear vertical scales calibrated in frequency and with the names of prominent medium- and long-wave stations; the principal short-wave broadcast and amateur bands are indicated.

The turret is constructed from sheet aluminium with brass bushes for all bearing surfaces. Polystyrene is used for supporting the switching contacts, and also for the coil formers; these have adjustable dust-iron cores.

Rotation of the coil turret is checked positively at each position by a ball-ended plunger locking into a circular indentation in the back plate. Provision is also made for short-circuiting the oscillator coil for the frequency band below the one in use, to prevent any harmful effects of resonance in the coil.

Accompanying each coil turret is a circuit diagram for a superhet receiver and instructions for assembling and lining up the circuits.

The price of the Type CT6 turret,

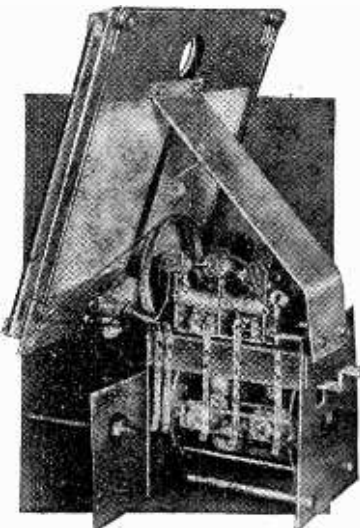

Denco five-range coil turret assembly for a superhet receiver. The large tuning scale is calibrated in frequency and with the names of the principal broadcasting stations.

as illustrated, is £4 ros and the makers are Denco, Ltd., 355-359, Old Road, Clacton-on-Sea, Essex.

Improved Twin Diaphragm Loudspeaker

BEFORE the war Goodmans "Auditorium" twin-diaphragm loudspeakers were widely used by quality enthusiasts on account of their wide frequency range, which extended to at least 12,000 c/s.

The post-war "Axiom 12" series, while bearing a superficial resemblance to the "Auditorium" range, is of entirely new design and incorporates several interesting features. The centre pole diameter has been increased from 1½ to 1¾ in and a magnet of higher energy has been fitted. The total flux is 145,000 maxwells and the density 13,000 gauss.

Increased power-handling capa-

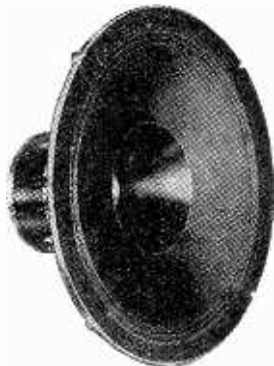

Goodmans "Axiom Twelve" loudspeaker. The coil impedance is 15 ohms at 400 c/s.

city has been achieved at low frequencies by the larger magnet, and at high frequencies by reinforcement of the edge of the inner cone by a light beading. This prevents the formation of "bell-tone" modes of vibration within the normal range of volume levels. It is stated that the maximum power capacity is 12 watts peak A.C., and the frequency coverage is 40 to 15,000 c/s.

The quality of reproduction is excellent and is maintained to much higher levels than in the earlier twin-diaphragm units. With the extended frequency range it is, of course, necessary to take more than usual care to eliminate harmonic and intermodulation distortion in the preceding amplifier, but when this is done the full power of which the Axiom Twelve is capable can be enjoyed with complete satisfaction. A bass reflex cabinet measuring approximately 30in x 23in x 16in has been specially designed for this particular loudspeaker and working drawings are available.

OUR COVER

The illustration on our cover shows the control console of the television transmitter at the works of Pye Ltd., Cambridge. This console enables test transmissions to be monitored both before and after passing through the transmitter.

The makers are Goodmans Industries, Lancelot Road, Wembley, and the price is £8 8s.

Crystal Sets—New Style

THERE seems to be a revival of interest in the crystal receiver for broadcast reception, and particularly in the adaptation of the wartime "crystal valve" to this purpose. These crystal valves, as is well known, are vastly more stable than the most "permanent" of the old-time crystal detectors; they comprise a silicon-tungsten junction sealed in a cartridge.

The British Thomson-Houston Company recommends the Type CS7A crystal rectifier. Though a series-tuned receiver circuit is best in the interests of good sensitivity and acceptable selectivity, it involves permeability tuning, and so the parallel-tuned circuit will generally be preferred for general use.* A circuit arrangement suggested by B.T.-H. is shown in the diagram below.

For a rectified current of about 20µA, which provides good signals with 2,000Ω phones, the impedance of the rectifier is about 10,000 ohms. With average circuit constants the rectifier output circuit should therefore be tapped down on the coil to include about one-quarter of the total number of turns, as shown.

The CS7A crystal rectifier, made by the B.T.-H. Company, Rugby,

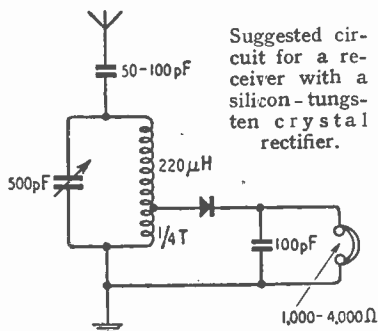

Suggested circuit for a receiver with a silicon-tungsten crystal rectifier.

costs 7s 6d; it is obtainable from Webbs Radio, 14, Soho St., London, W.1.

See our Exhibit at B.I.F., Olympia, Stand No. H42

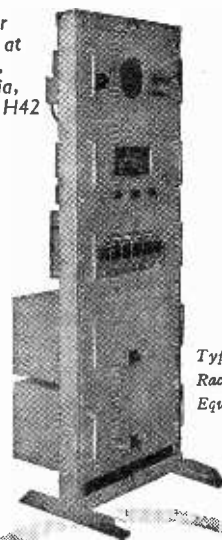

Typical Rack-Mounted Equipment.

Whatever your P.A. requirements

TRIX

Quality SOUND EQUIPMENT

will do the job



Moving Coil Microphone G.7806.

From high-power rack equipment serving as many as five hundred loudspeakers to low power portable mains and battery models, the Trix range includes sound equipment for every purpose and every type of installation. In Factories, Theatres, Public Buildings, Churches, Hotels, Schools, etc., it provides a standard of reproduction that satisfies the most critical and affords a reliable service over years of continuous use. Send to-day for illustrated brochure giving full details.

THE TRIX ELECTRICAL CO. LTD.
1-5 Maple Place, Tottenham Court Road,
London, W.1.
Grams & Cables: "Trixradio, Wesdo, London."
Phone: Museum 5817.

AMPLIFIERS - MICROPHONES - LOUDSPEAKERS

Random Radiations

By "DIALLIST"

Television a la Russe

IT IS MY WONT to skim through as many of the foreign wireless magazines as I can get hold of each month. In case you should start thinking "what a linguist the fellow must be," hold your horses and let me give you a tip. Do you want to gain a reputation as a linguist? Nothing easier. Take a copy of the Danish *Radio Industri*, or the Spanish *Radio y Electrotechnia* with you to the office, open it and, after some minutes of apparent absorption in its contents, remark brightly, "Jolly interesting, this Danish (or Spanish) article on pickups." If some disagreeable fellow suggests that you don't know a word of Danish, you probably won't have much difficulty in confounding him by a fluent translation of any paragraph he cares to name. With the drawings and circuit diagrams to help, it's often as easy as easy. The Danish (as well as the French and probably the Czech and the Magyar) for pickup is just pickup! Hosts of other key technical words are common to most civilized tongues and the illustrations help you to fill in many gaps. Russian is beyond my powers, but I lit a day or two ago on a French translation of an article on television from the Soviet magazine *Radio* in the *U.I.R. Bulletin*. Russia is going ahead with television in a big way. Stations at Moscow and Leningrad have been operating for some time and two others with a 25 kW power output rating for vision are to open in the near future. The present standard is the 625-line, but higher definition is contemplated with a view to big-screen displays and research. But Russia is a vast country, large areas of which are populated by folk living in widely separated small towns and villages. To attempt anything like nation-wide coverage by means of medium-power relays would entail enormous expense and huge amounts of materials. In the article in question a particularly bright idea is outlined. Calculations show that a simple aerial system 50-60 metres high should provide a

field-strength of 1mV/m over an area with a radius of 5 to 10 miles, even if the transmitter is rated at only a few hundred watts. Such transmitters, it is suggested, can be put together, largely from standard components, by enthusiastic amateurs all over the country. Presumably the municipality pays for the bits and pieces, for the transmitter is handed over, when finished, to the local authorities, who run it for the common entertainment. I can't think of any better way of getting television services of some kind (the standard proposed for these amateur-built stations is 240-line, 25 frames a second) going as quickly as possible in thinly populated areas. But having set up your transmitter—and, one imagines, provided a reasonable number of receivers—what are you going to transmit? Relaying is out of the question in view of the enormous distance and one doubts whether local talent could provide more than an occasional programme. Still, the construction of local low-powered transmitters by amateurs is a novel idea with some possibilities. It might be worth thinking about in other countries as well.

Spread of the H-shaped Dipole and Reflector

AS I WRITE, the erection of television aerials, suspended willy nilly during the spell of gales, frost and snow, is proceeding apace in my locality. Springtime is here, good and proper, and just to let "Free

Grid" see that I can quote Latin too when roused,

Ecce iterum gelidus canis de montibus humor Labitur

which the schoolboy translated: *ecce iterum, lo! again; gelidus canis, a cool dog; labitur, slides; de montibus, down the mountains; humor, by way of a joke.* Seriously, have you observed the rate at which television aerials are going up in and near London? I notice fresh ones nearly every time I journey to Town by train or Green Line. The little place in which I live has become very television minded. Like the inhabitants of most small towns we take the greatest interest in one another's doings. In our walks abroad we keep an eye on the chimney stacks for the appearance of new H-shaped collectors and tell one another that the Soandsos and the Thingmebobs have just installed a televisor. In fact, unless you live near enough to the Alexandra Palace to be able to use an indoor aerial, you can't help letting the world know it when you join the ranks of the televiewers. Most of those I talk to seem very satisfied not only with the entertainment but also with the size of the images provided by their 9-inch cathode-ray tubes. One good sign is that television receivers don't stay long in the windows or the showrooms of the radio shops. Actually, if there's one there at all it is usually on the point of being delivered to a customer and if you ordered one of well known make you'd probably be told that you'd be some way down on the waiting list.

News from the Clubs

Basingstoke.—A course of instruction including morse has been started for members of the Basingstoke and District Radio Society at their weekly meetings on Tuesdays at 7.45 in the Assembly Rooms, Potters Lane, Basingstoke. Sec.: L. S. Adams, 16, Bramblys Drive, Basingstoke, Hants.

Bexley.—The North Kent Radio Society now meets on Mondays at 7.30 at its new headquarters, Freemantle Hall, Bexley, Kent. Sec.: J. L. Bowes, G4MB, 20, Bloomfield Road, Bexleyheath, Kent.

Birkenhead.—Membership of the

Wirral Amateur Radio Society now totals 68, of which number 25 hold transmitting licences. Meetings are held on the first and third Wednesdays of each month at the Y.M.C.A., Whetstone Lane, Birkenhead, at 7.30. Sec.: B. O'Brien, G2AMV, 26, Coombe Road, Irby, Heswall, Cheshire.

Gloucester and District Amateur Radio Society now meets on alternate Thursdays at the Spread Eagle Hotel, Market Parade, Gloucester. Next meeting on April 1st. Sec.: J. W. Dean, G2AZT, 100, Stanley Road, Gloucester.

Loughborough.—Membership of the Beaumanor Amateur Radio Society is limited at present, but visitors are welcome at the weekly meetings on Sundays at 6.30 at the Club's temporary headquarters, 24, Brand Hill Camp, Woodhouse Eaves, Loughborough. Sec.: E. T. Pethers, Beaumanor Park, Loughborough, Leicestershire.

Newcastle-on-Tyne.—Meetings of the North-East Amateur Transmitting Society are now held on the last Monday of each month at 8.0 at the British Legion Rooms, 1, Jesmond Road, Newcastle-on-Tyne. Sec.: J. W. Hogarth, G3ACK, 4, Fenwick Avenue, Blyth, Northumberland.

Peterborough.—The annual general meeting of the Peterborough and District Radio and Scientific Society will be held on April 1st in the Technical School, Broadway, Peterborough. Weekly meetings are held on Thursdays. Sec.: R. S. Snell, 15, Buckle Street, Peterborough.

Sidcup.—Membership of the Gray Valley Radio Transmitting Club is limited to holders of G.P.O. transmitting licences. Meetings are held on the third Thursday of each month at the Adult Education Centre, Lamorbey Park, Halfway Street, Sidcup, Kent. Sec.: G. Miles, G2CXO, "Cotswold," Mottingham Lane, London, S.E.9.

Southend.—The Southend and District Radio Society now meets on alternate Fridays at 7.45 at the Art School, Victoria Circus, Southend. A series of lectures covering the syllabus for the Radio Amateurs' Examination is being given. The next meeting is on April 9th. Sec.: J. H. Barrance, M.B.E., G3BUJ, 49, Swanage Road, Southend-on-Sea, Essex.

Warrington.—Fortnightly meetings of the Warrington Radio Society, previously known as the Warrington and District Radio Society, are held on Mondays at 7.30 at the Junior Technical School, Arpley Street, Warrington. Sec.: J. F. Thomas, 510, Stockport Road, Thelwall, nr. Warrington, Lancs.

West Cornwall.—Meetings of the West Cornwall Radio Club are held each month in three centres. On the first Thursday at the Railway Hotel, Penzance; on the second and fourth Thursdays at the Railway Inn, Redruth, and on the third Thursday at the "Fifteen Balls" Inn, Penryn. All meetings begin at 7.30. A link between the three sections is maintained in the 3.5-Mc/s band one night a week. Sec.: R. V. A. Allbright, G2JL, Greenacre, Lidden, Penzance, Cornwall.

Wolverhampton.—An amateur radio exhibition is being organized by the Wolverhampton Amateur Radio Society and will be held from April 5th to 10th in the Co-operative Society Hall in Stafford Street. The event is being arranged in connection with the town's centenary celebrations. Sec.: H. Porter, 22r, Park Lane, Fallings Park, Wolverhampton, Staffs.

Worthing.—At the meeting of the Worthing Group of the R.S.G.B. on April 1st at 7.30 at Oliver's Café, 32, Southfarm Road, Worthing, a representative of the Mullard Educational Service will give a lecture on "An Introduction to Electronics—the Radio Valve." Sec.: G. W. Morton, 42, Southfarm Road, Worthing, Sussex.

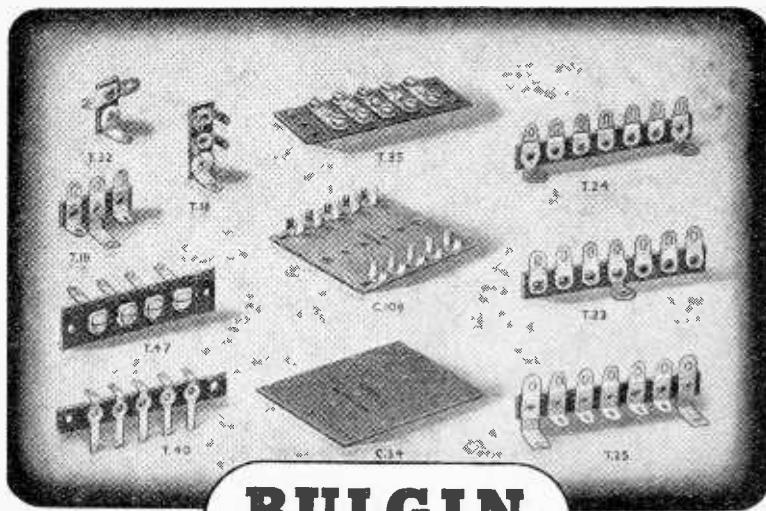

BULGIN

REGISTERED TRADE MARK

TAG STRIPS and GROUP BOARDS

THE BULGIN range of Tag Strips, Group Boards (with tags or holes), Captive-Screw Strips (4 B.A.) and Removable-Screw Connector Strips (4 B.A.) is most comprehensive and caters for all manufacturing requirements. The selection illustrated above, includes a few of our standard designs for upright mounting, centre-fixing, twin end-fixing, flush panel mounting and chassis-base mounting. Numerous standard types are manufactured, and special facilities exist for the production of individual designs, in quantity, to manufacturers' own requirements.

These components utilise the highest possible grades of low-moisture-absorbing S.R.B.P. or S.R.B.F. phenolic thermo-setting plastics-sheet, and non-ferrous metal parts, heavily silver plated. Tag strips are spaced $\frac{3}{8}$ " on $\frac{3}{8}$ " strip.

For working at 500v. max. pole-to-pole and to Earth. Insulation resistance is 40MΩ min. at 1KV. *peak*, dry.

*Enquiries for direct—and indirect—
export are particularly invited.*

"The Choice

BULGIN

of Critics"

REGISTERED TRADE MARK

A. F. BULGIN & CO. LTD. · BYE-PASS RD. · BARKING

Telephone: R1Pleway 3474 (5 lines)

RECENT INVENTIONS

A Selection of the More Interesting Radio Developments

MINIMIZING INTERFERENCE

IN short-wave reception, the down-lead from an elevated dipole to the set is responsible for most of the interference experienced. By amplifying the signal voltage actually developed across the aerial, before feeding it into the down-lead, a better signal-to-interference ratio can be applied to the main receiver.

As shown in the diagram, a small amplifying unit is enclosed in a waterproof casing W, which is mounted at the centre of the dipole A on the supporting bracket S. The unit consists

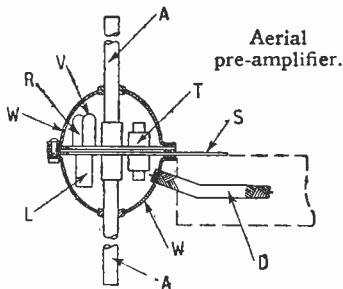

of an amplifier valve V, with tuning coil L, and a main transformer T feeding a rectifier R. Power is fed to the transformer through the inner and outer conductors of the screened down-lead D. The inner conductor also carries the amplified signal, which passes through isolating condensers to protect both the aerial unit and the main receiver from the supply voltage. D. Jackson and Pye, Ltd. Application date September 9th, 1944. No. 587627.

RELAYING SYSTEMS

WHEN transmitting television or other signals covering a wide frequency band from point to point over a series of relay stations, serious departure from linearity is likely to arise unless the relay circuits are carefully designed and supervised. But as such stations are usually unmanned, and carried on high masts, it is highly desirable that they should be as simple in character and operation as possible.

According to the invention, this is accomplished by the alternate use of positive and negative modulation. In other words, the incoming signals at one relay station are rectified and passed through a phase-inverter before

being applied to modulate the outgoing carrier wave from that station. In television, for instance, the synchronizing signals are re-radiated at maximum amplitude, whilst for high-light signals the reverse holds good. The successive changes in polarity serve automatically to check the normal progressive error in linearity. It also prevents "crossfire" between the transmitter and receiver at each relay, since any feedback will be negative.

The General Electric Co., Ltd., and D. C. Espley. Application date November 6th, 1944. No. 587498.

RADAR DISPLAYS

PERSISTENT echo signals from the ground, or from a relatively fixed object, are liable to burn or damage the sensitive screen of the cathode-ray indicator. Moreover, such images serve little useful purpose, except possibly after each change of view or alteration in range.

According to the invention, an auxiliary tube C₁ is used in parallel with the indicator tube C, the control grids of both tubes being fed from the signal amplifier A, whilst their deflecting plates receive identical scanning voltages from a generator G. The tube C₁ is fitted with a mosaic screen S of known type, together with a signal-collecting anode D, whilst the indicator tube has a sensitive dark trace

WAVE GUIDES

THE energy transmitted by a wave guide will not normally pass through a bend in the guide without

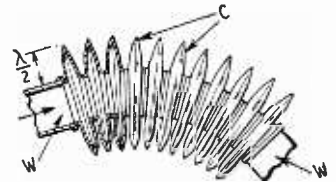

Flexible wave guide joint.

attenuation. Some reflection occurs whenever the waves come to a section of the guide that is out of alignment with the main axis, and this interferes with the steady flow of power.

It is now common practice in radar to use a wave guide for feeding centimetre waves to the rotating aerial scanner. The diagram shows a construction suitable for this purpose, since it allows the guide to be flexed in any direction without interfering with the efficiency of transmission. The concertina-like elements C consist of a series of resilient discs, each having a central aperture equal to the diameter

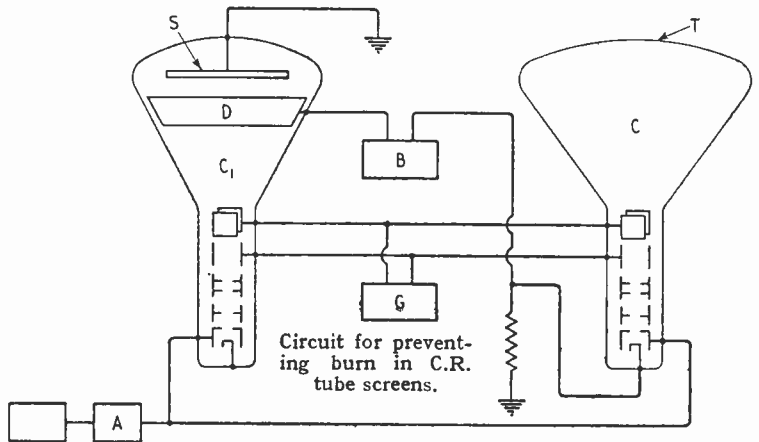

screen T. After the first few scanning cycles, the charges created by the fixed traces on the mosaic screen S will be sufficient to induce signals on the anode D. These are applied through an amplifier B, in the same phase, to the cathode of the indicator tube, where they can be used either to eliminate or reduce the intensity of the same signals on the screen T.

Standard Telephones & Cables, Ltd. (assignees of R. E. Rutherford). Convention date (U.S.A.) December 20th, 1943. No. 588155.

of the wave guide W, so that they form a continuation of it. The discs are soldered together in pairs along their outer edges, which extend beyond the periphery of the central channel for a distance equal to half the transmitted wavelength. They therefore act as an impenetrable series of high-impedance "chokes," and maintain a constant flow of energy through the central channel.

The British Thomson-Houston Co., Ltd. Convention date (U.S.A.) August 30th, 1943. No. 586458.

The British abstracts published here are prepared with the permission of the Controller of H.M. Stationery Office, from specifications obtainable at the Patent Office, 25, Southampton Buildings, London, W.C.2, price 1/- each.

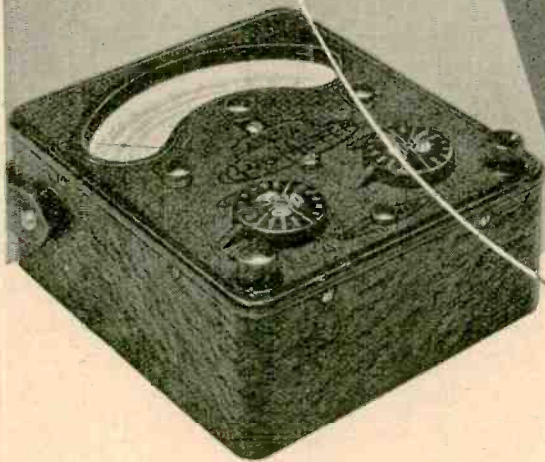
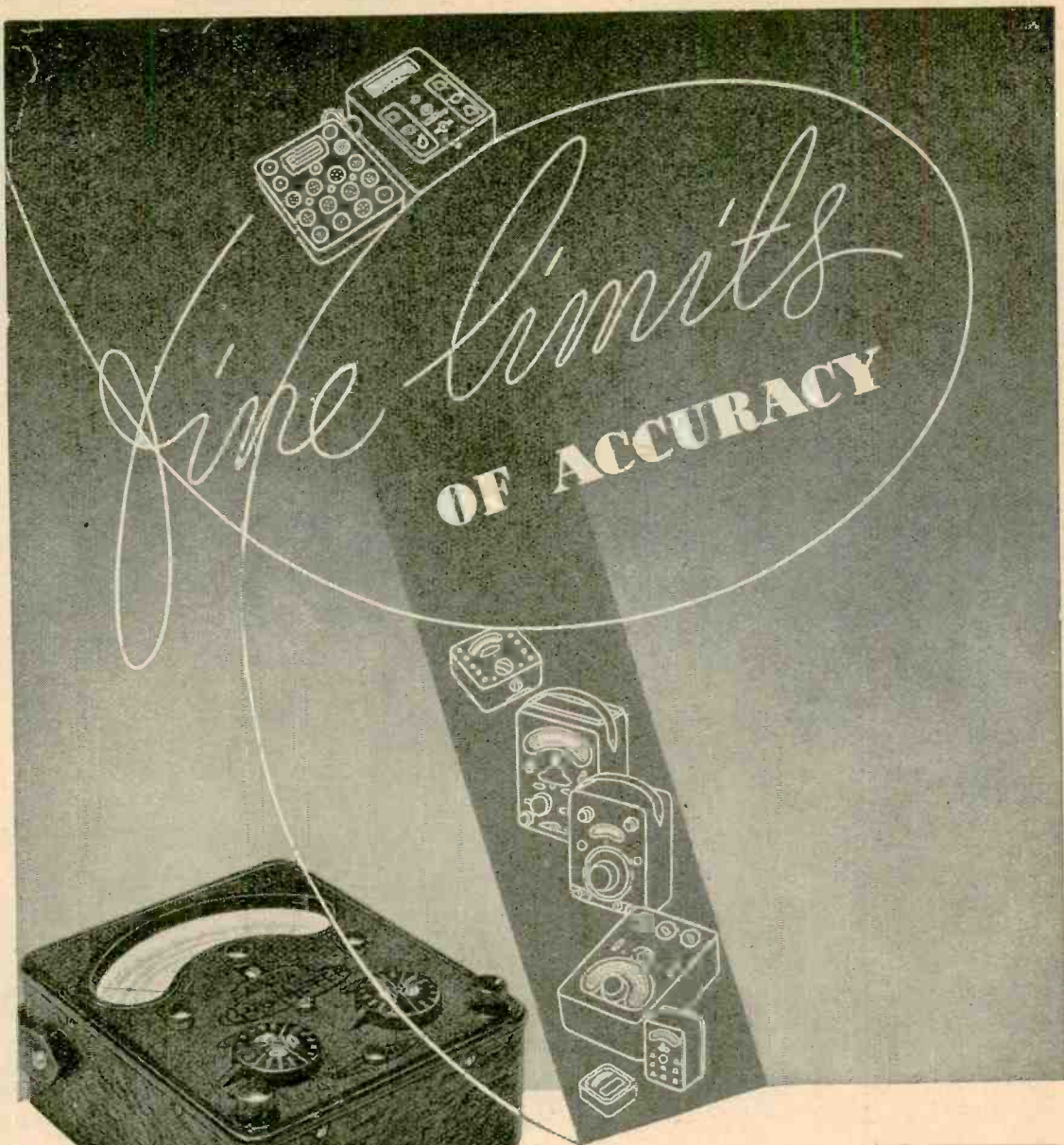

The 50-range Model 7 Universal AvoMeter, the pioneer of the comprehensive range of "Avo" Precision Instruments, is the world's most widely used combination electrical testing instrument. Fully descriptive pamphlet available from the Sole Proprietors and Manufacturers:—



"Avo" Instruments available from stock.
 VALVE TESTER
 TEST BRIDGE
 D.C. AVOMINOR

Electrical Measuring Instruments

THE AUTOMATIC COIL WINDER & ELECTRICAL EQUIPMENT CO., LTD.
 WINDER HOUSE - DOUGLAS STREET - LONDON, S.W.1 TELEPHONE - VICTORIA 3404/9



PIFCO

ALL-IN-ONE RADIOMETER

tests everything electrical, Radio and P.A. Equipments, Household appliances of all kinds, Car Lighting Systems, Bell and Teleprinter Circuits. May be used on AC or DC mains.

25/-

Still in short supply but ask your Local Dealer to put your name down on his waiting list.

The SHERLOCK HOLMES OF RADIO SINCE 1930

FIDELITY



EFFICIENCY

GOODMANS

Loudspeakers

The models illustrated here are part of a range which includes loudspeakers designed for every conceivable purpose and built to the exacting standards which have made the name "Goodmans Loudspeakers" synonymous with fidelity in reproduction and robust efficiency.

12-inch—Type T2/1205/15. The famous medium-heavy duty speaker. Suitable for general P.A. duties, small halls, and radiograms.

Impedance 15 ohms at 400 c.p.s. Total Flux ... 145,000 maxwells
Peak A.C. Input ... 15 watts Fundamental Resonance ... 75 c.p.s.

15-inch—Type T10/1501/15. An ideal reproducer for heavy duty P.A. systems, medium halls, etc.

Impedance 15 ohms at 400 c.p.s. Total Flux ... 215,000 maxwells
Peak A.C. Input ... 25 watts Fundamental Resonance ... 70 c.p.s.

18-inch—Type T11/1801/6. The loudspeaker for very high power amplifier systems, large theatres, and outdoor use.

Impedance 6 ohms at 400 c.p.s. Total Flux ... 267,000 maxwells
Peak A.C. Input ... 50 watts Fundamental Resonance ... 55 c.p.s.

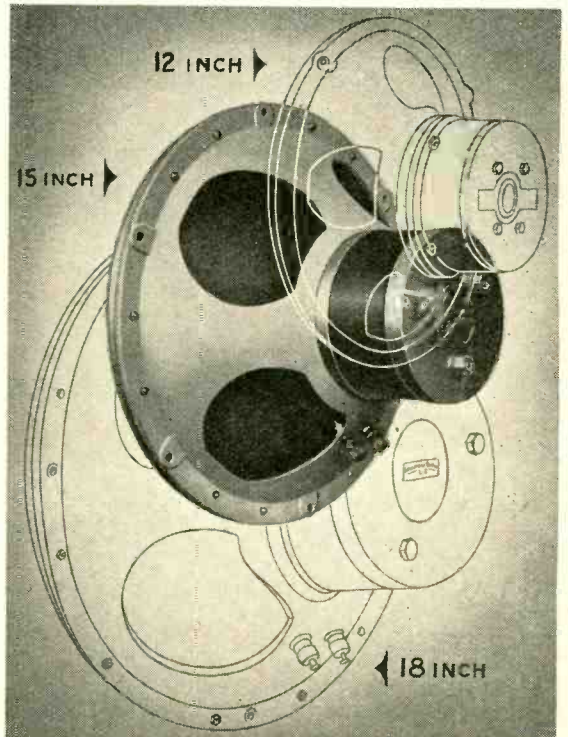

GOODMANS INDUSTRIES LTD.

B.I.F. STAND NO. H61, OLYMPIA
Lancelot Road, Wembley, Middx. Phone: Wembley 4001 (9 lines)



FOR more than 30 years, radio and electrical designers and engineers in all parts of the world have found their most exacting requirements met by the unrivalled Dubilier ranges of capacitors and resistors, renowned for their constancy and complete reliability under the most arduous operating conditions. These capacitors and resistors, so important in Radio, Radar and Television equipment, are being continuously developed and extended in order to provide for every conceivable application. Dubilier capacitors and resistors owe their unvarying quality, technical excellence and high degree of stability to the close control which is maintained throughout all stages of their manufacture.

Full technical data and prices supplied upon request.

DUBILIER

CONDENSER CO. (1925) LTD.

DUBILIER CONDENSER CO. (1925) LTD., DUCON WORKS, VICTORIA ROAD, NORTH ACTON, W.3
 Telephone: Acorn 2241 (5 lines) Telegrams: Hivoltecon, Phone, London
 Cables: Hivoltecon, London Marconi International Code
 D2A

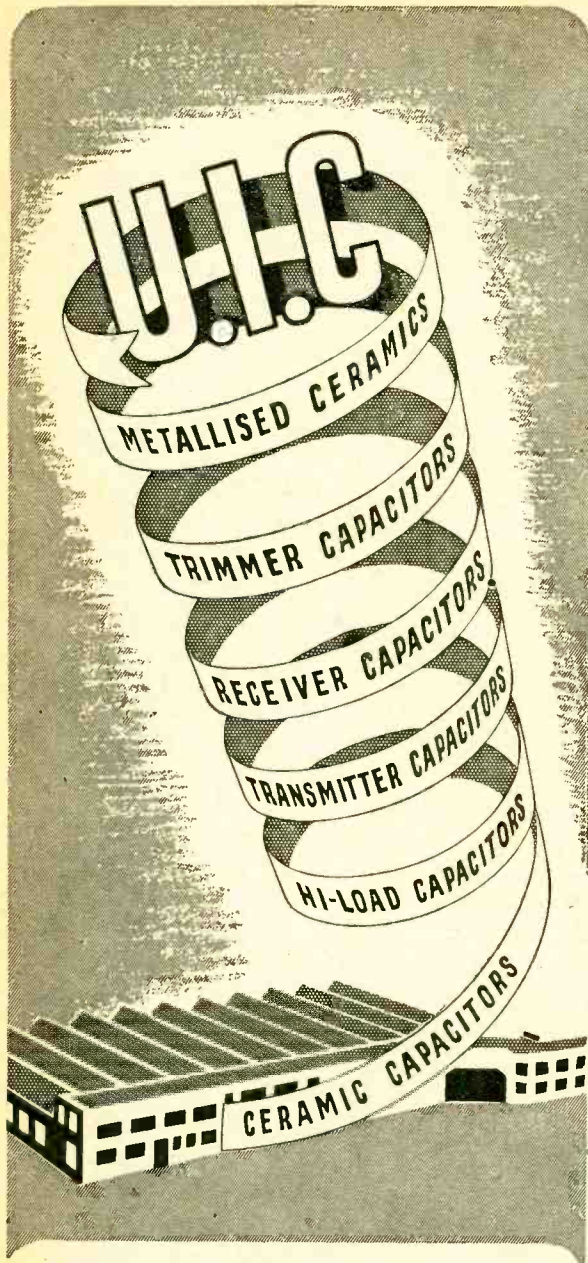

UNITED INSULATOR CO. LTD.

OAKCROFT RD., TOLWORTH, SURBITON, SURREY

Telephone: Elmbridge 5241

Telegrams: Calanel, Surbiton

Unsurpassed
in
Ceramics



New in P.A. equipment . . .

The new P.A.20B, an improved version of the well-known P.A.20 Portable Amplifier, embodies many interesting features. These include: Increased gain; improved output transformer, giving a true 20 watts distortionless output, with tapings for 7.5, 15 and 500 ohm (100v line) outputs; 600 ohm input for B.S.R. Ribbon Microphone type R.B.M. 1 (illustrated above) and provision for working the B.S.R. Radio Feeder unit.

Supplied in an attractive case and available for immediate delivery.

Full details available on request. Also send for details of Recording Amplifier R.1



BIRMINGHAM SOUND REPRODUCERS LTD.

Claremont Works, Old Hill, Staffs. Phone: Cradley Heath 6212/3



FOR THE RADIO SERVICEMAN DEALER AND OWNER

The man who enrolls for an I.C.S. Radio Course learns radio thoroughly, completely, practically. When he earns his Diploma, he will KNOW radio. We are not content merely to teach the principles of radio, we want to show our students how to apply that training in practical, every-day radio service work. We train them to be successful.

Write to the I.C.S. Advisory Dept. stating your requirements. Our advice is free.

.....You may use this coupon.....

INTERNATIONAL CORRESPONDENCE SCHOOL Ltd.

DEPT. 38, INTERNATIONAL BUILDINGS, KINGSWAY, LONDON, W.C.2

Please explain fully about your instruction in the subject marked X.

Complete Radio Engineering Radio Service Engineers
Radio Service and Sales Advanced Short-Wave Radio
Elementary Electronics, Radar, and Radio

And the following Radio Examinations:—

British Institution of Radio Engineers
P.M.G. Certificates for Wireless Operators
City and Guilds Telecommunications
Wireless Operators and Wireless Mechanics, R.A.F.

I.C.S. students for Examinations are coached till successful.

Name..... Age.....

Address.....



A matter of Balance...



High fidelity in radio and television is a matter of precise balance in the circuit. A matter too, of knowing that B.I. Callender's manufacture types of low-loss radio frequency cables in standard ranges covering all telecommunications and electronic requirements involving frequencies up to, and even higher than 3,000 Mc/s.

This publication contains useful technical information and details of the standard radio frequency cables made by B.I. Callender's. Write to-day for free copy of Publication No. 223.



RADIO FREQUENCY CABLES

BRITISH INSULATED CALLENDER'S CABLES LIMITED
NORFOLK HOUSE, NORFOLK STREET, LONDON, W.C.2

A WITCH DOCTOR MIGHT AS WELL TRY

A witch doctor might just as well try to find certain faults in a defective wireless set as a skilled engineer without a good test instrument. A Weston Model E772 Analyser will help you find radio faults in the easiest and quickest way. This instrument will save you time, trouble and money, and you will find it universally useful for a wide range of measurements. Features of the instrument are high sensitivity—20,000 ohms per volt on all D.C. ranges—simplified controls, robust construction, accuracy and dependability.

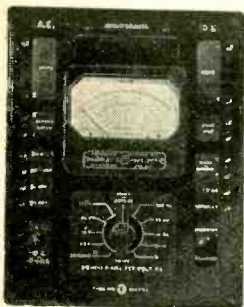

ANALYSE SYSTEMATICALLY WITH A **WESTON**

SANGAMO WESTON LTD. ENFIELD, MIDDX.

Telephone: Enfield 3434 & 1242

THE NEW "ACRU 24"

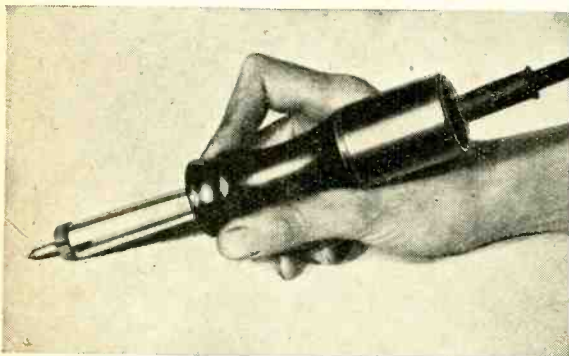

Instrument Type Iron with Unparalleled Features

ELEMENT. Totally enclosed, die-cast, airtight, crash-proof and virtually everlasting. 45 and 50 watts.

HANDLE Perfect balance and heat-reflecting for delicate control.

COPPER BITS. Instantly detachable and interchangeable. Screwless lock.

Ask your Radio Dealer or write direct for full details.

THE ACRU ELECTRIC TOOL MFG. CO. LTD.

123 Hyde Road, Manchester, 12
ARDwick 4284

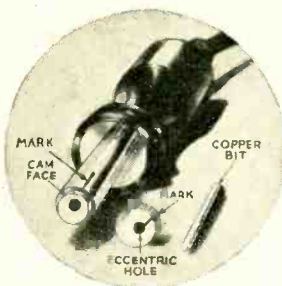

Miniature or Midget

ACTUAL SIZE

50%

10 1/4"

XY 1-4A

ACTUAL SIZE

24%

10 1/4"

XW 0-75A

NEW TYPES FOR
MIDGET RECEIVERS
HEARING AIDS
METEOROLOGICAL
INSTRUMENTS
ETC.

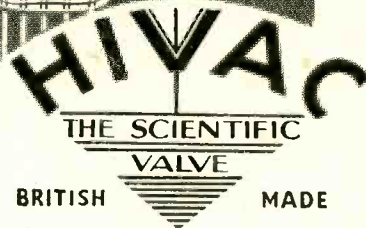

HIVAC LIMITED Greenhill Crescent. Phone HARROW
Harrow on the Hill, Middx. O895

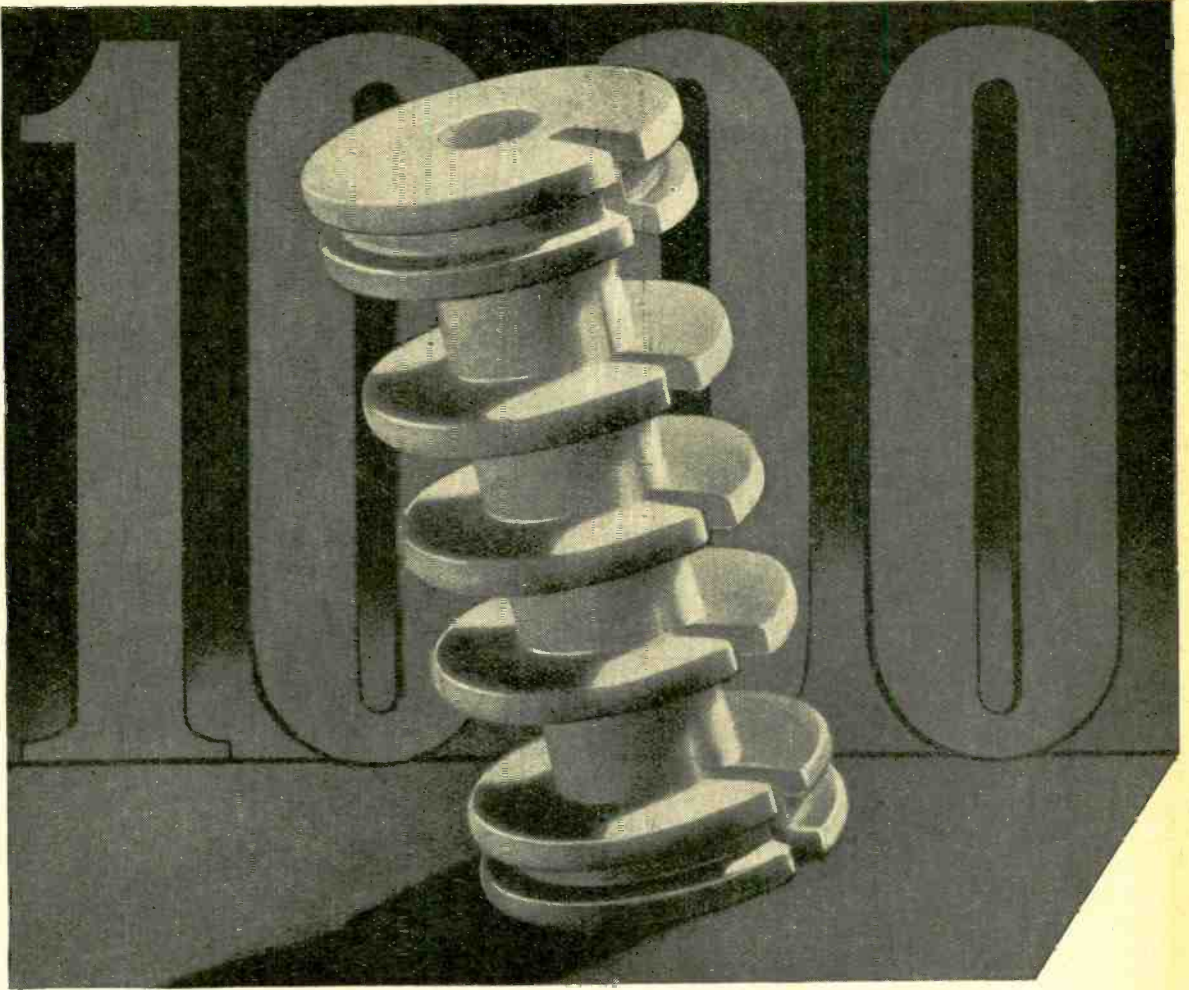

one in a thousand

Fifteen years ago we introduced the first British-made low-loss ceramic. To-day the range of **Frequentite** components covers more than a thousand pieces of every shape and size.

With such a store of manufacturing experience we are able to offer advice backed by practical knowledge on your insulation problem. Please consult us before you finalize your design.



STEATITE & PORCELAIN PRODUCTS LIMITED

Head Office: Stourport-on-Severn, Worcs.

Telephone: Stourport 111

Telegrams: Steatain, Stourport

S.P.24

Presenting the New Model D

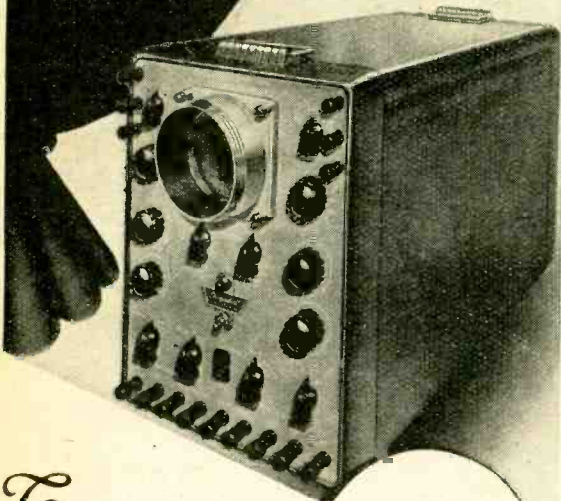

The Type 1684 series of Oscilloscopes is already well known. The new Model retains the desirable features of this series—d.c. shift controls, response flat to video frequencies, d.c. coupled symmetrical amplifiers on both axes, semi-automatic synchronisation of the time base, etc. It incorporates many new features of design, both electrical and mechanical. One such improvement is that the grids of the input stages of both amplifiers are available at Earth potential enabling the instrument to be used more easily for d.c. measurement.

PRINCIPAL FEATURES

- ★ TUBE 3½ in. diam. Blue, green or delay screen.
- ★ AMPLIFIERS. D.C. to 3 Mc/s., 18 mV. r.m.s. per cm. or D.C. to 1 Mc/s., 6 mV per cm. Symmetrical or asymmetrical input. X and Y amplifiers are similar.
- ★ TIME BASE. 0.2 c/s to 150 kc/s. Variable through X amplifier 0.2 to 5 screen diameters.
- ★ ACCESSORIES. Camera, telescopic light shield, ruled graticule.



Fitzchill LABORATORIES LTD
BOREHAM WOOD, HERTS
Telephone: ELSTREE J137

ISOLATION FROM VIBRATION

NEW VIBRATION ELIMINATORS



"EQUIFLEX"
REGISTERED AND FOREIGN PATENTS PENDING
MOUNTINGS

AN  PRODUCT

"Equiflex" Mountings are invaluable for the mounting and suspension of machines, equipment, instruments,

electrical apparatus, motors, etc., and whenever elimination of vibration and shock is required.

SPECIAL FEATURES

Flexible in all directions at an equal deflection. Can be loaded on any side, thus eliminating vibration in Vertical, Horizontal and Longitudinal planes employing best quality natural rubber spring elements and complete with snubbing device. Special Fittings made to suit customers' requirements.

Also available as previously advertised, the ALL-METAL construction comprising an ingenious Damped Spring System

Write for illustrated brochure, and send us details of your requirements.

A. WELLS & CO. LTD. (Dept. W.W.),
STIRLING ROAD, WALTHAMSTOW, LONDON, E.17
Phone: Larkwood 2691

M. R. SUPPLIES Ltd.

offer only selected and brand new material which is sure to give complete satisfaction

All orders handled with the utmost diligence and despatch. All prices net.
BATTERY CHARGERS (ex-Air Ministry—brand new). Operation 200/250 v. A.C. Output 5 amps at 15 v. D.C., Metal (S.T.C.) Rectified, fitted sliding resistance, 0.6 ammeter, fuse, lead, etc., ready for use. For charging all batteries 2 to 12 volts and ideal for garage. 5 in. steel housing 13in. by 13in. by 7in., with wall mounting lugs. £7 15/0 (retail £8 1/2).

R. THERMEL AMPLIFIERS. Exceptional half-price opportunity for a first-class job. Operation 220/240 v. A.C. Output 6 watts. Suitable for small halls and for domestic use, employ two 42 valves in push-pull. Inputs for crystal mic. and any pickup, with switch-over. Output matched to standard commercial impedance of 24 ohms. Compact size: 12in. by 7in. by 5in. Complete with five valves (List £25) £12 15/0 (des. 5).

SYNCHRONOUS ELECTRIC CLOCK MOVEMENTS. 200/250 v. 50 c. Fitted spindles for hours, minutes and seconds. Centre-bush fixing. With dust-cover and flex-lead—the perfect movement for the home constructor, 37 6.

ROTARY CONVERTERS (ex-Admiralty). Input 160/110 v. D.C. Output 250 v. 50 c. Rated at 200 watts (but users report drawing up to 750 watts). Fully enclosed, 13in. by 11in. by 9in. Weight approx. 100 lbs. £10 carr. paid.

ANODE CONVERTERS (Rotary Transformers). This is the really useful one. Input 12 v. D.C. output 250 volts 125 ma. D.C. Ideal for mobile radio and small amplifiers. Brand new, perfect, in-steel cartons, 19 6.

VARIAC TRANSFORMERS. Input continuously variable from 200 to 250 volts by manual control, for maintaining constant voltage from fluctuating mains. Oil filled. Model "A," loading 1.65 kva., output 220 v. £7 10/0. Model "B," loading 1.01 kva., output 230 v. £6 10/0 (des. either 3/9).

SHORT-WAVE RECEIVERS. Last few of the excellent B2 MkIII Receivers and Power Packs. Operation any A.C. mains and 6 volts D.C. Range 3.1 to 15.5 mc/s. Superhet with B.F.O. Compact and highly efficient sets with phones, all leads, etc., in watertight steel transit case, £7 17/6 (des. 5/). COILS for the B2 Mk III Transmitter, 10/6 set of four.

STEP-DOWN MAINS TRANSFORMERS. All continuously rated, with 10 per cent added spec. for ageing. Our transformers are well-known for their excellent construction. All with brackets and terminal boards. All primaries tapped 200-220-240 v. Sec.: 22 v. 2 amps., 22 - . Sec.: 7, 11, 15 v. 2 amps., 23 6. Sec.: 30 v. 4 amps., 57/6. 50 v. 1 amp., 29 6. 8 and 15 v. 4 amps., 38 6. 5, 12 and 17 v. at 6 amps., 55 - . 8 and 15 v. at 12 amps., 77 6 (des. p. train 3/6). 36 v. 7.2 amp., £4/4 0 (des. 5/6). And others.

HEAVY DUTY OUTPUT TRANSFORMERS. Improved "W.W." spec., providing 11 ratios from 12/1 to 75/1 with C.T. for P.P., handling up to 25 watts. Weight 7 1/2 lbs. There is no better O trans. 59 6 (des. 1/6).

GERMANIUM CRYSTAL RECTIFIERS (G.E.C.). 13 mm. long, Range 60 c. to 45 mc. Many applications—discriminator and limiting circuits, second detectors, meter rectifiers (A.P. and R.F.), in place of diodes, valve voltmeter, etc., 27 6.

E.H.T. RECTIFIERS (S.T.C.), (600 v. 4 ma., 15 6; 2,000 v. 4 ma., 25 -).

PIEZO-ELECTRIC HEADPHONES (Rothermel). Presenting a great opportunity for a limited number of pairs, with adjustable headbands, new and perfect, at half list price. Response 60 to 10,000 c/s. Weight only 6 ozs. Used in the normal way and ideal for many special purposes. (List £2 10/0). A few pairs at only 32 6.

STEEL TRIPPODS for Public Address. Extending to 12 feet. The best type, strongly made and rigid under all likely stresses, 55 - (desp. 3/6). **LOUSE-SPEAKER CABINETS.** Well made portable type with compartment for leads, etc., 17in. square by 6 1/2 in. deep. Strongly made of wood, sprayed brown, 27 6 (des. 2/-).

Please include sufficient for packing and despatch.

M. R. SUPPLIES Ltd., 68, New Oxford Street, London, W.C.1

Telephone: MUSeum 2958

TECHNICAL TOPICS

for Amplifier designers



● Single, or push-pull circuits.

The simplest output circuit uses a single power valve, and indeed modern valves, particularly pentode and beam tetrodes, are designed to give adequate power as a single unit. With low impedance triodes or indirectly heated pentodes or tetrodes wired as triodes, a push-pull arrangement is usually desirable to minimise 2nd harmonic distortion.

Push-pull circuits are popular in high quality amplifiers because of the increased available power and the tendency to 'balance out' 2nd harmonic distortion. It must be remembered however that the push-pull circuit has the same overall sensitivity as the single valve, that is for double the output, the total grid input must be doubled. The load impedance will vary with conditions of use, whether 'Class A', 'Class B' or 'Class AB', and for all conditions except for 'Class A' (where the grid bias is the same as for a single valve), and the equivalent anode to anode load double, good 'regulation' of the H.T. supply is essential. Output power for typical valves in single and push-pull arrangements are shown below.

TYPE OF OUTPUT VALVE	Approx. power (watts)	
	Single Valve	Push Pull
KT2 (2 volt)	0.5	1.0
KT76 (DC/AC)	2.0	4.8
KT33C (DC/AC)	5.0	15.5
KT63	3.0	6.0
KT61	4.3	11.5
KT61 (Triode connected)	—	6.0
KT66	7.25	up to 50
KT66 (Triode connected)	5.8	up to 14.5
PX4	4.5	up to 13.5
PX25	8.5	up to 25

Osram
PHOTO CELLS

S.E.C.
CATHODE RAY TUBES

Osram
VALVES

SPRING LOADED TERMINALS

A Positive CONNECTION WITHOUT SOLDER · SIMPLY PRESS & RELEASE



PAINTON

PAINTON & CO. LTD · KINGSTHORPE · NORTHAMPTON · ENGLAND

Simon
SOUND SERVICE

THE COMPLETE SERVICE FOR SOUND RECORDING AND REPRODUCTION

- ★ Mobile and Static Continuous Recording Outfits.
- ★ Recording Amplifiers.
- ★ Moving Coil and Crystal Microphones
- ★★ Sapphire Pointed Reproducing Styli and Cutters.
- ★ Blank Recording Discs from 5in. to 17in. Single or Double sided.
- ★ Light-weight moving iron, permanent sapphire and moving coil pick-ups.
- ★ Label and Envelope Service.
- ★ A comprehensive range of accessories to meet every requirement of the sound recording engineer.
- ★★ And our latest development (of special interest to users of sapphire or delicate pick-ups)—The **Simtrol**.
This is a controlled micro-movement easily fitted for use with any type of pick-up to eliminate the danger of damage to the record or pick-up. This is achieved by a vernier lowering action of the pick-up head to the record.

Write for comprehensive lists or call at
Recorder House for demonstration.

RECORDER HOUSE, 48/50 GEORGE ST.
PORTMAN SQUARE, LONDON, W.1.

Telephone: WEL 2371/2 Telegrams: Simsale, Wesdo, London

H. P. Radio Services Ltd. offer—

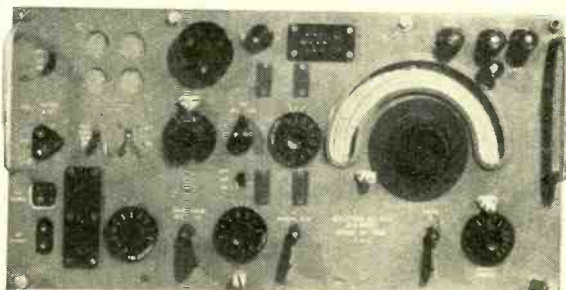

Ex-Army Reception Sets, Type R107. 9 Valve receiver designed for CW and RT signals. Weight 96 lbs. Length 24 ins. Height 13 ins. Depth 17½ ins. Frequency range 17.5-7 mcs., 7.25-2.9 mcs., 3.0-1.2 mcs. Highly Sensitive and Selective. A.C. mains 100-250 volts or 12 volt accum. Mains Consumption 31 watts Circuit RF Amplifier. Oscillator. Frequency Changer. Two IF stages (465kcs) Second detector. AVC. AF amplifier. Output Stage and Heterodyne Oscillator (beat). Three types of valves used—EF39, EBC33, 6X5. 12 volt non sync. vibrator pack fitted. Monitor loudspeaker built in. Amazing value £16 16 0 carr. paid.

All in first-class order and condition.

Terms: Cash only. (No C.O.D. or Hire Purchase)

We are still offering Ex-Govt. Combined Moving Coil Headphones and Moving Coil Hand Microphone. Guaranteed perfect 9/6. post. 8d.

We guarantee
satisfaction and safe delivery.

H. P. RADIO SERVICES LTD.

Britain's Leading Radio Mail Order House

55 County Rd., Walton, Liverpool, 4.

Tel.: Aintree 1445



Announcing... SIX ENTIRELY NEW

ELECTRONIC INSTRUMENTS

by CINEMA-TELEVISION LIMITED

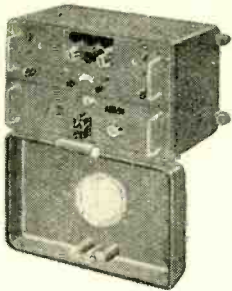

INDUSTRIAL ELECTRONIC METAL DETECTOR

An automatic inspection equipment for the detection of ferrous and non-ferrous metal particles of all kinds in non-metallic substances such as foodstuffs, plastics, textiles, tobacco, timber, pharmaceutical products, etc.



STANDARD ELECTRONIC COUNTER

A high speed electronic counter of particular appeal to the industrialist. Facilities are provided for batching, selective counting etc., the maximum counting-speed for the equipment being 30,000 per minute.



UNIVERSAL OSCILLOSCOPE

A unique instrument meeting fully the requirements of the serious users of oscilloscopes for laboratory and industrial purposes, arranged to permit readily the assembly of suitable units to fulfil every application. Complete range of units is available, e.g. stabilised time base, A.C. and D.C. amplifiers, 5 beam switch unit etc.

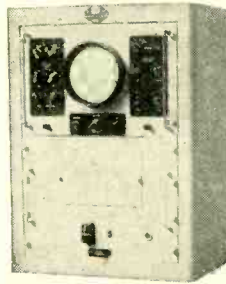

LABORATORY OSCILLOSCOPE

A high grade 6" screen oscilloscope expressly designed for laboratory use, incorporating hard valve linear time base, 3 megacycle "Y" amplifier and 1 megacycle "X" amplifier. Cupboard and trolley are available if required.

DEMONSTRATION OSCILLOSCOPE

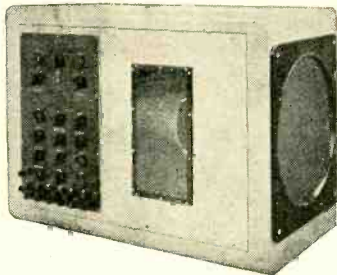

FOR LECTURE PURPOSES

Demonstrator and student alike will acclaim the features of this equipment—15" tube with glare removing filter, 2 beam switch for simultaneous delineation of two recurrent wave forms, or their "addition" to produce a single resultant trace. Provision is made for setting up from rear of instrument.

PROCESS TIMER



A compact instrument, from the "CINTEL" range, providing simple and accurate electrical control for scientific and industrial processes of every kind. The timing range extends from 0.25 to 90 seconds.



Regd. Trade Mark.

CINEMA-TELEVISION LTD.,
INCORPORATING BAIRD TELEVISION LIMITED
WORSLEY BRIDGE RD., LONDON, S.E.26

Telephone: HITHer Green 4600

Suppliers to ADMIRALTY, MINISTRY OF AIRCRAFT PRODUCTION, MINISTRY OF SUPPLY, ARMAMENT RESEARCH, etc. Manufacturers of Scientific Instruments and Photo-electric cells.

Heavy Duty

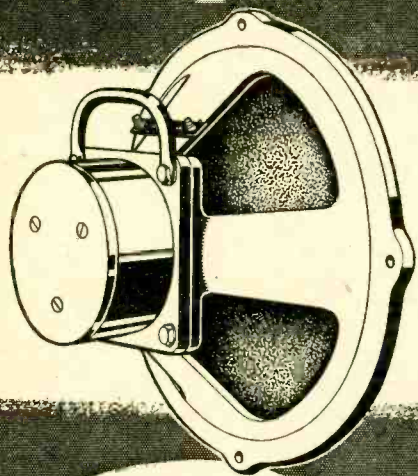

Rigid diecast chassis ; square casting for the magnet seating, secured with large hexagon head bolts ; centre pole and bottom plate all in one forging ; ring-clamped cone ; die-cast centring ring ; practical construction matched by excellent response and high sensitivity — all made for Heavy Duty. The Truvox 12" P.M. Speaker will convince your most critical friends that your latest amplifier "has something." Truvox leaflet SH/152 gives all the technical detail — a postcard brings it to you.

Model SS.9			
75—8,000 c.p.s.	15 watts peak	£6 . 15 . 0	
Model SS.9A			
55—8,000 c.p.s.	12 watts peak	£6 . 15 . 0	
Model SS.10			
75—11,000 c.p.s.	12 watts peak	£6 . 17 . 6	
Model SS.10A			
55—11,000 c.p.s.	10 watts peak	£6 . 17 . 6	

TRUVOX

TRUVOX ENGINEERING CO. LTD.
EXHIBITION GROUNDS, WEMBLEY, MIDDLESEX

Special Waxes
FOR THE

ELECTRICAL INDUSTRIES

Manufacturers of electrical and radio materials and components are invited to investigate

OKERIN

WAXES AND DI-JELS

for insulating, waterproofing, impregnating, sealing and finishing condensers, cables, transformers, batteries, resistances, etc.

For technical data and samples
please telephone TEMPLE BAR 5927

Sales Department

ASTOR BOISSELIER & LAWRENCE LTD

NOFOLK HOUSE · NOFOLK STREET · STRAND · W.C.2

Ardente

Type VMC

• First quality moving coil Microphone of exceptional frequency response and sensitivity.

Contained in a handsome black ripple and polished aluminium case of small dimensions. A combined shock absorber and remote control switch is fitted to the base in a casting, which is threaded to take the stem of the microphone stand.

Impedance: 20 ohms. Output level: 40db. Overall Dimensions: 2½" dia., 2¼" deep, 5½" high. Weight 1½ lbs. Desk Stand, adjustable 9" to 14", Black and Chrome. Table Base and Heavy Base Floor Stand also available.

ARDENTE ACOUSTIC LABORATORIES LTD.
GUILDFORD, SURREY.
Guildford 3278.

London Branch: 309, Oxford St., W.1, Mayfair 7917

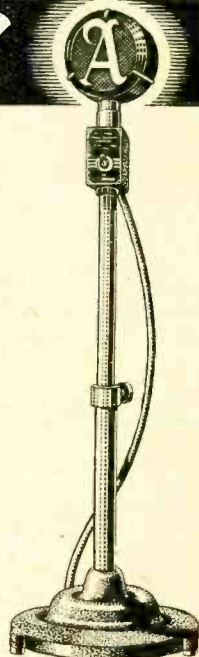

MAZDA

for

DEPENDABILITY

SP61*



RATING :

Heater Voltage	6.3
Heater Current (amps)	0.6
Maximum Anode Voltage	250
Maximum Screen Voltage	250
‡Mutual Conductance (ma/V)	8.5
‡ Taken at $V_a=200: V_s=200: V_g=1.5$		

GENERAL :

The SP61 is a high slope screened H.F. Pentode designed for use on A.C. mains in the H.F. and I.F. stages of a Television receiver.
Other uses are:

1. Video amplifier in circuits where the capacity across the output load is low.
2. Frequency changer in conjunction with a separate oscillator valve such as the P61.
3. Certain classes of audio amplification work where gains of over 150 can be realised.

The valve is fully metallised and is fitted with a Mazda octal base.

* Also made with 4v. heater and known as SP41
LIST PRICE 10/6 (plus 3/5d. purchase tax)

P61†



RATING :

Heater Voltage	6.3
Heater Current (amps)	0.6
Maximum Anode Voltage	250
§ Mutual Conductance (ma/V)	8.0
§ Amplification Factor	17
Maximum Peak Anode Current (mA)	30
Maximum Anode Dissipation (watts)	4.0
§ Taken at $V_a=100: V_g=0$		

GENERAL :

The P61 is a triode and has been primarily designed for use as an oscillator in television receivers. It may also be used as an oscillator in all-wave receivers where a single valve frequency changer is not employed.
The valve is fully metallised and is fitted with a Mazda octal base.

† Also made with 4v. heater and known as P41
LIST PRICE 9/6 (plus 3/1d. purchase tax)

THE EDISON SWAN ELECTRIC COMPANY LIMITED

RADIO DIVISION

155 CHARING CROSS ROAD, LONDON, W.C.2

Available Now

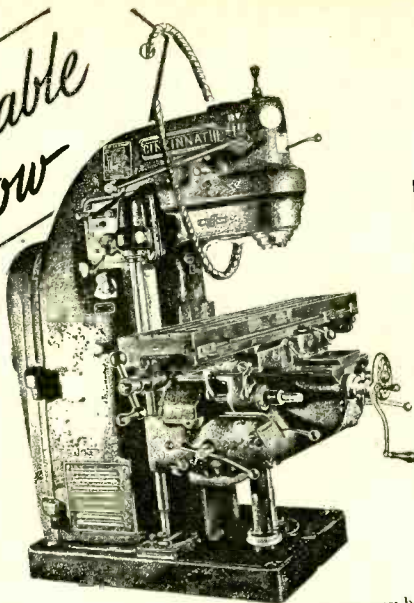

HUNDREDS OF DIFFERENT TYPES MACHINE TOOLS

No fewer than 26,000 Government Surplus machine tools are available for purchase to help you in your drive for increased production. Your nearest Disposal Centre will tell you whether they can meet your requirements. If you have enquired previously, try again, because additional machine tools frequently become available.

DISPOSAL CENTRES, where records of all machines available may be inspected, are open to enquirers from 10 a.m. to 4 p.m. Monday to Friday inclusive—LONDON—Room 0088, Ground Floor, Thames House North, Millbank, S.W.1. BIRMINGHAM—C.M.L. Buildings, Great Charles Street. BRISTOL—8/9 Elmdale Road, Bristol 8. GLASGOW—21 Glasford Street. LEEDS—10 Bank Street, off Boar Lane. MANCHESTER—Britannia House, Fountain Street.

ISSUED BY THE MINISTRY OF SUPPLY

RAYTHEON CONTRIBUTIONS to development of Hearing Aids

Little value outlasts big one...

5 TO 1

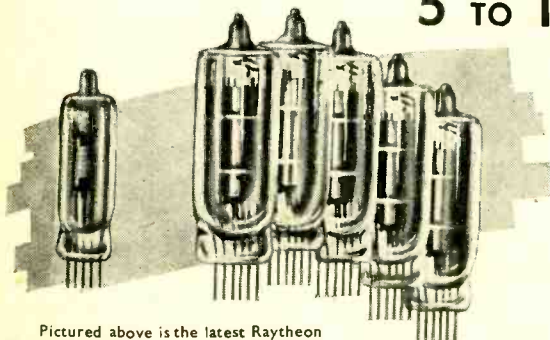

Pictured above is the latest Raytheon Flat Hearing Aid Valve... the CK512AX... and a group of the earliest Raytheon Hearing Aid valves. Apart from the improvement in hearing qualities, just look at the difference in size! Though less in height and of much smaller cross section, the present Raytheon Flat Valve provides five times the life. This is but one of many developments which have made Raytheon the leading Hearing Aid Valve... outnumbering all other makes combined by nine to one!

Ask for complete information. Address your inquiry to Submarine Signal Company (London) Ltd., Artillery House, Artillery Row, London, S.W.1, England or to:

South African Distributors: Lynch-Wilde (Africa) (Pty.) Ltd., Jo'burg.



RAYTHEON MANUFACTURING COMPANY
INTERNATIONAL DIVISION
60 EAST 42nd STREET
NEW YORK 17, N. Y., U. S. A.

SPHERE INSTRUMENTS

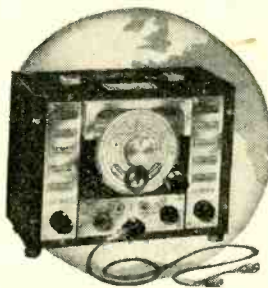

Introducing the ALL WAVE SIGNAL GENERATOR TYPE 505

A portable Signal Generator for AC. Mains operation. Specially developed by SPHERE as a high class instrument, for general Laboratory and Workshop use, it is the ideal instrument for the aligning and testing of radio receivers and amplifiers.

This is a specially designed Generator embodying several new and unique features and improvements, which radio engineers will find invaluable.

All "SPHERE" Test-instruments are entirely British made with highest quality materials and workmanship and carry a SIX Months' guarantee.

- Continuous Frequency coverage from 110 Kilocycles to 56 Megacycles, in six bands.
- Exclusive "SPHERE" "SEE AT A GLANCE" Band and Attenuator indicators.
- Built In ladder attenuator, with fine control, giving 1 Volt maximum, in five steps, in multiples of 10 Microvolts.
- Radio and Audio Frequency Voltages can be switched via single Test-lead.
- Variable control of 400 C.P.S. audio, from 0 to 1 Volt.

FOR RADIO SERVICE, RADIO ENGINEERING AND LABORATORY USE.

Write for List No. 505 S.G.

SPHERE RADIO LIMITED

Radio Instrument Manufacturers

HEATH LANE, WEST BROMWICH

BRITISH INDUSTRIES FAIR

MAY 3-14

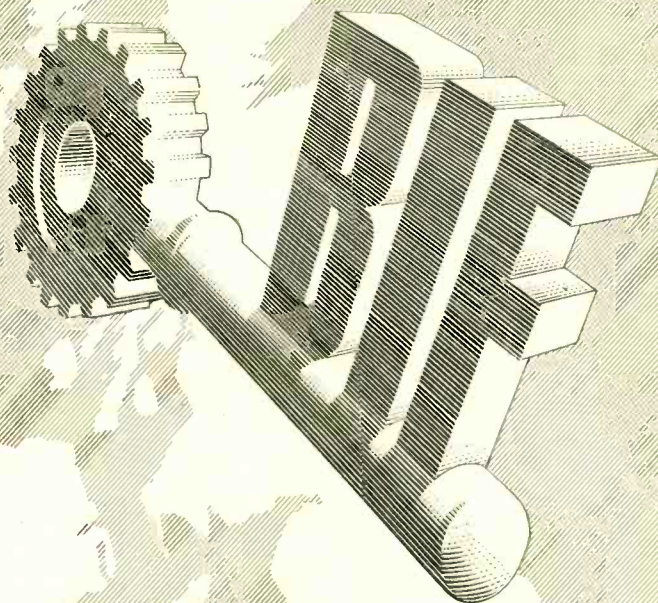

BIRMINGHAM
Castle Bromwich

Admission 10 a.m.—6 p.m. daily (except Sunday). Trade Buyers' Badges (2/6d.) and Catalogues obtainable ONLY at the Fair. PUBLIC admitted every day—charge 2/6d.

LONDON
Olympia & Earls Court

Buyers' Admission 9.30 a.m.—6 p.m. daily (except Sunday). Trade Buyers' Badges (2/6d.) and Catalogues obtainable ONLY at the Fair. PUBLIC are admitted (all day) on Wednesday, May 5, Saturday, May 8 and Wednesday, May 12. Charge 1/6d. each building.

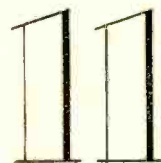

GREAT DAYS for Trade Buyers ★

Again the B.I.F.—world's largest national Trade Fair. 3,000 exhibitors presenting the latest achievements of British Industry. New ideas. New methods of manufacture. Superb craftsmanship. An immense display of high-quality goods, conveniently grouped by trades for inspection and comparison. Eleven days of unequalled opportunity for manufacturers and the world's buyers to get together . . .

★ **RADIO EQUIPMENT AT OLYMPIA**

PREMIER RADIO

(MORRIS AND CO. (RADIO) LTD.)
ALL POST ORDERS TO: 167, LOWER CLAPTON ROAD, LONDON, E.5. (Amherst 4723)
CALLERS TO: 169, FLEET STREET, E.C.4. (Central 2833)
 SEND 21D. STAMP FOR LATEST LIST.
TERMS OF BUSINESS: Cash with order or C.O.D. over £1.

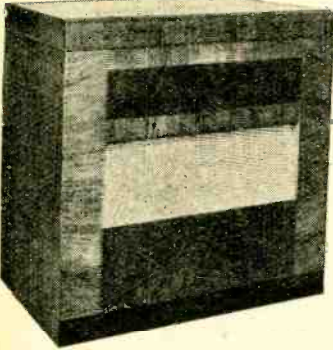

RADIOGRAM CABINETS

Dignified appearance and good workmanship. Size 31½ in. high, 18½ in. deep, 33 in. wide. French polished, veneered walnut. Price £29. Also available complete with electric motor, auto stop and magnetic pick-up, £37/18/11. Ditto, with Rothermel Crystal Pick-up, £39/12/8. Or with 8 record-mixer changer, £49/10/9.

ALL-WAVE SUPERHET KIT

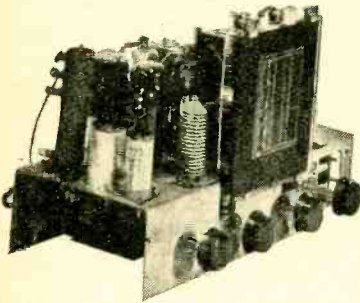

A Kit of Parts to build a 6-valve (plus rectifier) receiver, covering 16-50 metres. Medium and Long-wave bands. Valve line-up 6X8, 6K7, 6Q7, 6B7, two 25A6 in push-pull. Metal Rectifiers are incorporated for H.T. supply. Output impedance is for 3 and 15 ohms. The latest Wearable Coil Pack incorporates Iron Dust Coils is used, making construction and alignment extremely simple. A pick-up position on the wavechange switch and pick-up terminals is provided. A complete kit including valves but without speaker or cabinet. Chassis size

14 x 16 in. Overall height, 9 in. Price £11/16/3. Suitable loudspeakers are the GOODMAN'S 10 in. 6-watt P.M. at 47/6, or for superlative reproduction, the Goodman's 12 in. P.M. at £6/15/-.

MIDGET RADIO KIT

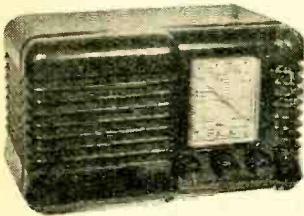

Build your own midget radio. A complete set of parts, including valves, loudspeaker and instructions. In fact, everything except cabinet necessary to build 4-valve Medium and Long Wave T.R.F. radio operating on 200-250 v. A.C./D.C. or A/C only. Please state which is required. Wavelengths covered 200-557 and 700-2,000. Size 10 x 8 x 6 in. Completely drilled chassis. Price, including tax, £8/0/11.
SUPERHET MIDGET RADIO KIT. A complete kit of parts for a 5-valve superhet. Covers 16-50 and 200-587 metres. AC/DC 200-250 v., or A/C only. Please state which is required. Size, 10 x 6 x 6 in. including tax, £9.
 An attractive brown bakelite cabinet can be supplied for either kit at a cost of 27/3.

GOVERNMENT SURPLUS

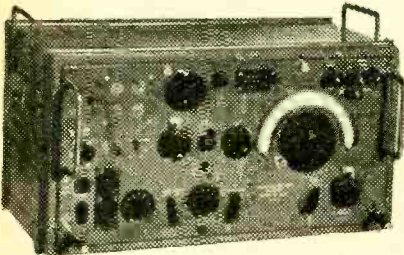

R107. ONE OF THE ARMY'S FINEST COMMUNICATIONS RECEIVERS. (See W.W. Aug., 1945.) 9 Valves, R.P. amp. osc. Frequency Changer, 2 IF's. (485 kc.), 2nd Detector, AVC. Af. amp. AC mains, 100-250 v. or 12 v. accum. Frequency range 17.5 to 7 m/cs. 7.25 m/cs. to 2.9 m/cs. 30 to 1.2 m/cs. Monitor L.S. built in complete. Write for full details. £16/16/- complete.

UNREPEATABLE!!!

TRIPLETT LATEST MULTI-RANGE METER

The Finest 'Ham' Meter made

Designed exclusively for Amateur use. Supplied Complete with black hide carrying case, at less than to-day's price for a meter without any of the following features:—

- (1) The Meter is 1,000 ohms per volt.
- (2) Its self-contained batteries allow of accurate measuring from as low as ½ ohm to ½ megohm. Even higher ranges can be obtained with the use of external batteries.
- (3) Current ranges are 10, 100 and 500 mA.
- (4) Volt ranges are 10, 50, 250, 1,000 and 5,000 volts at 1,000 ohms per volt, both A.C. and D.C.



With this Meter there is no metering problem that you cannot tackle on the spot and with one instrument.

It is complete with test leads, fine black hide carrying case and in its makers' original carton. Supplies are limited.

OUR PRICE WHILE THEY LAST IS

ONLY 9 GUINEAS

Make sure of yours NOW.

RADIOMART

48, HOLLOWAY HEAD, BIRMINGHAM, 1

The Connoisseur

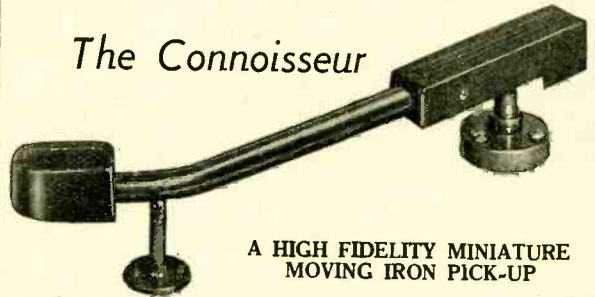

A HIGH FIDELITY MINIATURE MOVING IRON PICK-UP

Faithful reproduction of all recordings from 12,000 c.p.s. to 30 c.p.s. will win many new friends for the CONNOISSEUR miniature moving iron Pick-up in 1948.

The CONNOISSEUR reveals a wide range of notes and instruments that has hitherto been hidden by bass and treble resonance. The CONNOISSEUR will reproduce every sound on the record. Try it and prove it.

Note new prices. Pick-up 54' - plus 17/7 P. tax Transformer 13' - nett.

Apply to
 Albion Electric Stores, 125, Albion Street, Leeds 1
 or to
 Lawton Bros. (Sales) Ltd., Henry Square, Ashton-under-Lyne

Made by
 A. R. SUGDEN & Co. (Engineers) Ltd., Brighouse, Yorks



**RADIO, TELEVISION and
ELECTRONIC COMPONENTS**



LOUDSPEAKER
CONTROL PANEL
CAT. No. LSC 398/0

GRAM - JACK
PANELS
CAT. No. GJP/0

Clix Components are adequately protected by British and Foreign Patents

This panel is designed for inclusion in radio receivers and extension circuits where series or parallel speaker points must be individually controlled.

Positive On/Off switch action.
Speaker or P.U. plug readily removed from panel.

BRITISH MECHANICAL PRODUCTIONS LTD.

21 BRUTON STREET, BERKELEY SQUARE, LONDON, W.1.

Telephone : MAYfair 5543

**IAL DATA SHEET N°2
AMPLIFIER TYPE 84**

THE TYPE 84 AMPLIFIER IS RECOMMENDED FOR GENERAL PURPOSE INVESTIGATION OF A.C. AND COMBINES SIMPLICITY, LIGHT WEIGHT, EASE OF CONTROL WITH EXCELLENT PERFORMANCE.

FEATURES IN DETAIL

Single-ended input is employed with P.P. cathode follower output. A two-position switch gives maximum gains of 25 and 600 approximately, in both cases the high impedance introduces negligible load on the signal source. In the minimum position the gain control is so arranged that an overloading input voltage causes a deflection considerably in excess of the screen diameter. A switch arranges the internal connection to Y plates to terminals on the front panel with D.C. or A.C. coupling, and for single or P.P. input, the amplifier being inoperative. Falling off in response at high frequencies is quite gradual, and substantial gain remains at 500,000 cps.

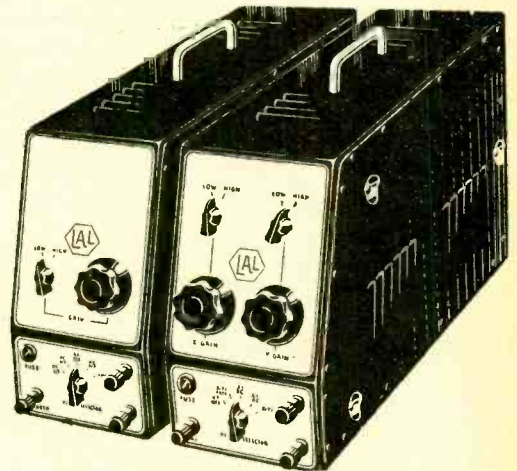

FOUR MODELS ARE AVAILABLE

TYPE 84YP uses voltage supplies from Time Base Type 84.
TYPE 84YP with self-contained power pack.

TYPE 84XYP as 84YP but incorporates two identical amplifiers for X & Y axes.

TYPE 84C to special order, two amplifiers cascaded for use on Y axis to give voltage gain of 40,000.

Full details on request.



**Lydiate Ash
LABORATORIES**

LYDIATE ASH - NEAR BROMSGROVE - WORCS.

LONG RANGE LISTENING

—with any set!

Throughout the house, if necessary—certainly for the kitchen and by the bedside for hearing all your favourite programmes when it is not convenient to be where you keep your receiver. This is something you should have in this modern age—it can be obtained easily by simply plugging a superlative Stentorian Speaker into the receiver. In handsome wooden cabinets of acoustic design.

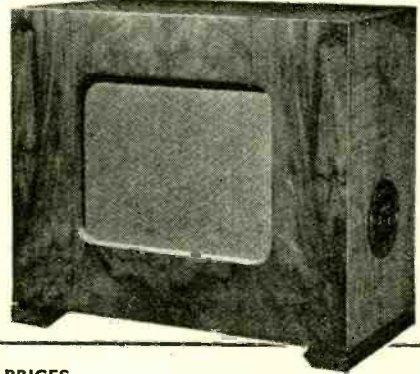

Stentorian

—the finest extra **SPEAKER** for any set

WHITELEY ELECTRICAL RADIO CO. LTD. MANSFIELD · NOTTS.

PRICES

SENIOR Model	Type SC*	£5 15 6	Type SX	£5 2 6
JUNIOR Model	Type JC*	£5 0 0	Type JX	£4 10 6
CADET Model	Type CC*	£4 10 0	Type CX	£4 0 0
BABY Model	Type BC*	£2 19 6	Type BX	£2 13 6
MINOR Model	Type MC*	£2 5 6	Type MX	£1 19 6

*With universal transformer.

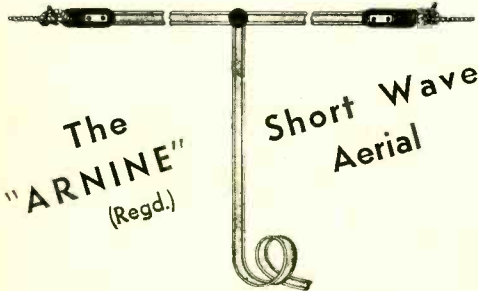

The
"ARNINE"
(Regd.)

Short Wave
Aerial

For reception or transmission. Load factor 1.9 Kw. at 7 m/cs. Aerial spans and down lead consist of twin parallel feeder of 300 ohm impedance, polythene insulated. Pack includes all the necessary insulators, fittings, etc., for easy erection.

Model FDA20 — £3 2 6
,, FDA40 — £3 12 6

ANTIFERENCE
LIMITED

Sales Division :

67, Bryanston St., Marble Arch, London, W.1

Telephone : PADdington 7253/4/5

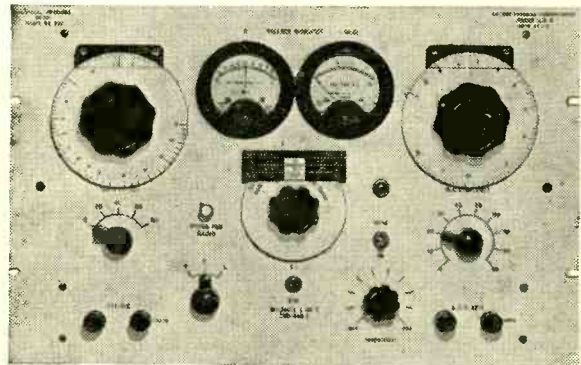

UNIVERSAL IMPEDANCE BRIDGE

MODEL UB 202

This is a self contained universal bridge which measures resistance at DC, Capacity and Inductance at 1000 Cycles. The necessary bridge voltage and null detectors are incorporated in the instrument. Measurements in condensers can be carried out with applied polarising voltage and inductances can be measured with superimposed DC.

Resistance Range .01 ohm to 1 megohm

Capacity Range 10 pf. to 1000 mFds.

Inductance Range 10 μ H. to 1000 Henries

For particulars of this and our full range of measuring instruments write to:—

BRITISH PHYSICAL LABORATORIES

HOUSEBOAT WORKS, RADLETT, HERTS

Telephone : Radlett 5674-5-6

Technically

We believe that the only way to build a receiver is to begin at the beginning with a sound circuit design—a design that's been tested and re-tested—a design that will stand up to the most critical examination. From this design a prototype is constructed in which every component receives the same rigorous testing. We leave the experts to pass judgment on the resulting Sobell receivers. We are confident that for ease of control and absolute fidelity of reproduction these models will be found to have no equals—that, in fact, you will pronounce them to be 'technically outstanding'.

Outstanding

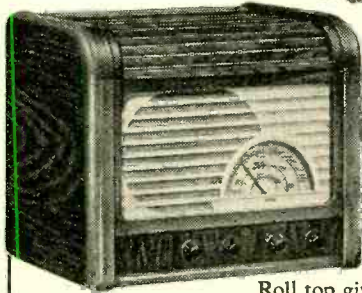

**SOBELL
MODEL 516
T.G. TABLE
RADIOGRAM**

Roll top gives easy access to gramophone turntable. The receiver is a 5-valve super-het. operating from 200/250 volts, 40/100 cycles per second A.C. supply. Wave range: 16-50 metres; 193-577 metres; 800-2, 140 metres.



**SOBELL
MODEL 717
7-VALVE
RECEIVER**

Built with a push-pull output stage giving 8 watts undistorted output. Incorporates a 10" loudspeaker. Covers long, medium and two short wave ranges. Voltages as for 516 T.G.

SOBELL RADIO

TWO YEARS' FREE ALL-IN SERVICE IN THE HOME
 Advt. of Sobell Industries Ltd., Langley Park, near Slough, Bucks. 8S-8

all about SOLDER and SOLDERING



This interesting booklet "The Evolution of Activated Rosin Cored Solder" should be in the hands of every user of Solder. Write for your copy.

"Superspeed Special" Activated Rosin Cored Solder.

Solid Solder Wire	Tinmans', Plumbers'
Lead Wire	and Blowpipe Solder
Tin Wire	Ingot Solder

"Telecene" Liquid Activated Rosin Based Flux.

"Tricene" Soldering Fluid.

H. J. ENTHOVEN
AND SONS LIMITED

**230 THORNTON RD., WEST CROYDON,
SURREY, ENGLAND.**

Telephone: THORnton Heath 2462

LONDON CENTRAL RADIO STORES

PHOTO ELECTRIC CELLS

Small infra-red image, glass converter tube. Type C.V. 143. 50—100 v. Suitable for all purposes.

Price **21/-** each.



Kindly note: We cannot enter into correspondence regarding these Cells.

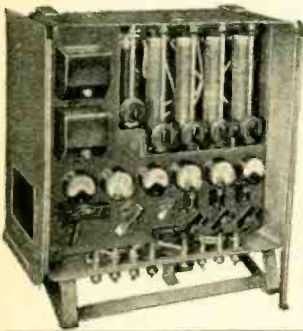

CHARGING BOARDS

Control Panels Only as illustrated

24 v., 1,260 watts. Includes five 1½ in. moving coil ammeters (1, 0-40 a., 4, 0-15 a.). One moving coil voltmeter 0-40 v. Five heavy duty sliding resistances, etc., complete in metal case as shown with fold-back doors. Size, 18 × 17 × 8½ ins. Offered at less than half the component value.

Price, carr. 12/6 extra **£4.19.6**

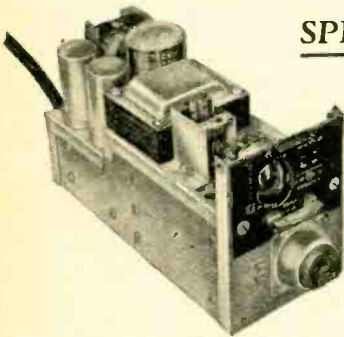

SPECIAL OFFER

2-VOLT POWER PACKS

Complete with Vibrator

Output approx 200 v., 60 ma. Size 9 × 5 × 3½ in. A first-class job. Price **£1.17.6**

VIBRATORS

2-v. input. Self-rectifying type. Output approx. 200 v., 60 ma. Price **7/6**

10-VALVE COMMUNICATION RECEIVER—Type R1155



These sets are as new. Need only a power pack for immediate use (see "W.W." July, 1946). Freq. range 7.5 mc/s 75 kc/s in five wavebands. Complete with 10 valves including magic eye. Enclosed in metal case. Every receiver is aerial tested. Set only **£12.10.0**

Complete with Power Pack and Loudspeaker, for A.C. mains **£20**
200-250 v. (Carr. and pkg. 10/6 extra.)

FREE with each receiver! Complete circuit, description and modifications for civil use, reprinted from "W.W." July, 1946.

Please Note: All carriage charges relate to the British Isles only • We do not issue lists or catalogues.

23, LISLE ST. (GERrard 2969) LONDON, W.C.2

Closed Thur: 1 p.m. Open all day Sat. and weekdays 9 a.m.—6 p.m.

LOWEST EVER

attenuation & capacitance



CO-AX CABLES

for RADIO FREQUENCIES

LOW ATTEN. TYPES	IMPED. OHMS	ATTEN db/100ft at 100 Mc/s.	LOADING K/W	O.D.
A1	74	1.7	0.11	0.36"
A2	74	1.3	0.24	0.44"
† A34	73	0.6	1.5	0.88"

LOW CAPAC. TYPES	CAPAC. mmf/ft	IMPED. OHMS	ATTEN db/100ft 100 Mc/s.	O.D.
C 1	7.3	150	2.5	0.36"
* PC 1	10.2	132	3.1	0.36"
C 11	6.3	173	3.2	0.36"
C 2	6.3	171	2.15	0.44"
C 22	5.5	184	2.8	0.44"
C 3	5.4	197	1.9	0.64"
C 33	4.8	220	2.4	0.64"
C 44	4.1	252	2.1	1.03"

† Bending Radius 5"
* Photocell Cable.

TRANSRADIO LTD. 138A CROMWELL ROAD, LONDON, S.W.7.

Cyldon

MICA DIELECTRIC TRIMMER Capacitors



Type No. 19



Type No. 22

SYDNEY S. BIRD & Sons Ltd.

CAMBRIDGE ARTERIAL ROAD, ENFIELD, MIDDX.
Phone: Enfield 2071-2 Grams: Capacity, Enfield.

WESTINGHOUSE
WESTALITE

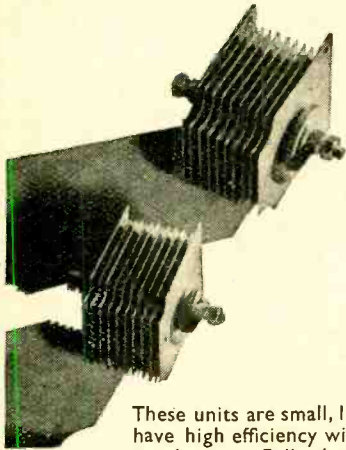

These units are small, light and have high efficiency with good regulation. Full details are given in publication M.R.14 Suppt. I, a copy of which may be obtained from Dept. W.W.

RECTIFIERS for AC/DC RECEIVERS

Type	Normal Output		Max. Input Volts AC/DC	Reservoir condenser		Circuit	Dimensions			Approx Weight Ozs.
	Volts	mA		mFd.	Wkg. Volts		Ht.	Wdth	Lgth.	
HT.46* 4A79	240	120	250	16	350	Half-wave	2½"	2¼"	4⅜"	8½
HT.47* 14A46	260	60	250	16	350	Half-wave	2½"	2¼"	3⅝"	6¼
HT.48* 15B46	260	30	250	8	350	Half-wave	1⅝"	1¾"	3⅜"	3½

* Units available to bona-fide manufacturers, who should ask for Data Sheet 49

WESTINGHOUSE BRAKE & SIGNAL CO. LTD., 82, York Way, King's Cross, London, N.1

Difficult Problems?

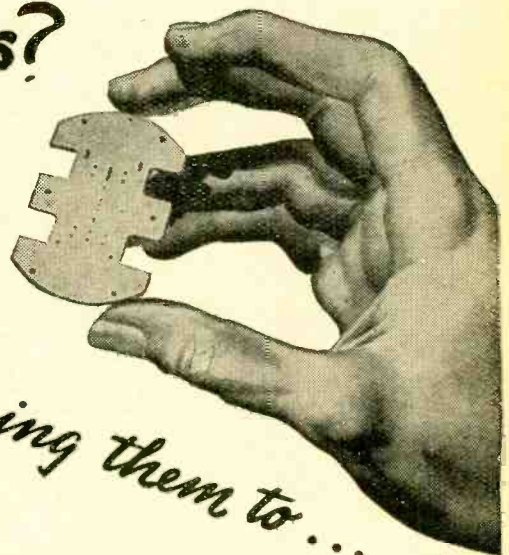
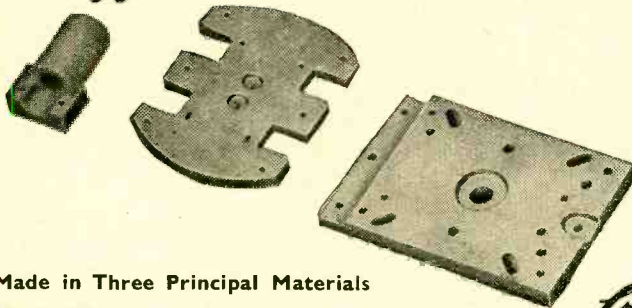

bring them to...

Made in Three Principal Materials

FREQUELEX

An insulating material of Low Di-electric Loss, for Coil Formers, Aerial Insulators, Valve Holders, etc.

PERMALEX

A High Permittivity Material. For the construction of Condensers of the smallest possible dimensions.

TEMPLEX

A Condenser material of medium permittivity. For the construction of Condensers having a constant capacity at all temperatures.



Bullers

BULLERS LOW LOSS CERAMICS

BULLERS LTD., 6, LAURENCE POUNTNEY HILL, LONDON, E.C.4
Telephone: Mansion House 9971 (3 lines) Telegrams: "Bullers, Cannon, London"

R&A

'Co-axial Construction'

THE magnet assembly of the "700" Series is unique in design, enabling approximately 25% more of the available energy in a given weight of magnet to be usefully employed in the gap. Assemblies of from 7,000 to 10,000 Gauss may be obtained with magnets of different height and weights.

The main body of assembly "A" is machined in the bore and on the outside diameter to limits of $\pm .00075"$. The outer pole "B" has its bore and outside diameter machined simultaneously to limits of $\pm .0005"$ as are also the outside diameter and bore of the centre pole centralising member "C", whilst the inner pole "D" is produced from precision ground bar of the same tolerances.

Whilst the assembly of this unit is extremely simple, it will be obvious that by virtue of the design and the limits on diameters to which each part is held, the inner and outer poles must be concentric within extremely close limits and, further, cannot be displaced from their relative positions by shock.

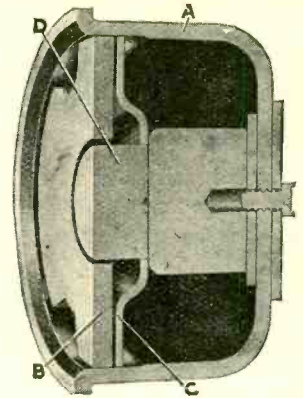

Reproducers & Amplifiers Ltd., Wolverhampton

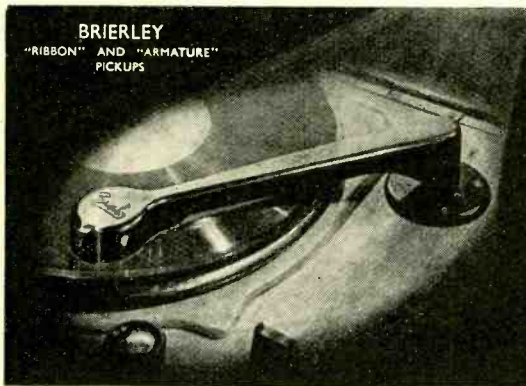

BRIERLEY
"RIBBON" AND "ARMATURE"
PICKUPS

RIBBON TYPE

Fixed point pressure of $\frac{1}{4}$ oz.
Output Voltage 10 to 15 mV.
Price in U.K. including special
Mumetal screened transformer
and Purchase Tax. £10 2s. 4d.

The Ribbon Pickup now being produced has a new *unbreakable ribbon*. Whilst the mass has been reduced, the effective damping has been increased without increasing the point stiffness. This feature in conjunction with a modified magnetic circuit has resulted in an increased output and an audibly better response at high frequencies putting this pickup even further ahead of any type hitherto available.

The design of these Pickups is such that any developments resulting from our continuous efforts to improve the quality of reproduction from gramophone records may readily be incorporated in existing models. Write for full details.

Demonstrations of Ribbon and Armature Pickups in conjunction with our standard Pre-amplifier and Low-Pass Filters: London, Webbs' Radio, Soho St., W.1.; Manchester, Holiday & Hemmerdinger Ltd., Hardman St.

Arrangements can be made for the loan of equipment to Radio and Gramophone Societies wishing to give special demonstrations of the High Fidelity Reproduction of Gramophone Records.

J. H. BRIERLEY (Gramophones & Recordings) LTD.,
46 Tithebarn Street, LIVERPOOL, 2.

ARMATURE TYPE

Fixed point pressure of $\frac{1}{4}$ oz.
Output voltage, $\frac{1}{2}$ to 1v.
Price in U.K. including special
Mumetal screened transformer
and Purchase Tax. £8 15s. 9d.

• CONSTANT VOLTAGE • POWER SUPPLY UNITS

NEW SERIES 101

Our new Laboratory Power Supplies, Series 101, are based on our well-known Model 101-A, but incorporate a number of improvements and refinements.



DETAILS ON REQUEST.

ALL-POWER TRANSFORMERS LTD.
8a, GLADSTONE ROAD, WIMBLEDON, S.W.19

Tel.: LIBerty 3303.

CONSISTENTLY *Accurate*

Pullin Miniature Instruments are characterised by their robust construction, good damping, excellent finish and pleasing appearance. The square types enhance the appearance of rectangular switchpanels.

A complete series of square flush type instruments with styled covers is now available in 2", 2½" and 3½" dial sizes.

Complete range includes Moving Coil ; Rectifier ; Thermo-couple, for all sizes ; and Moving Iron AC/DC types in the Series 35.

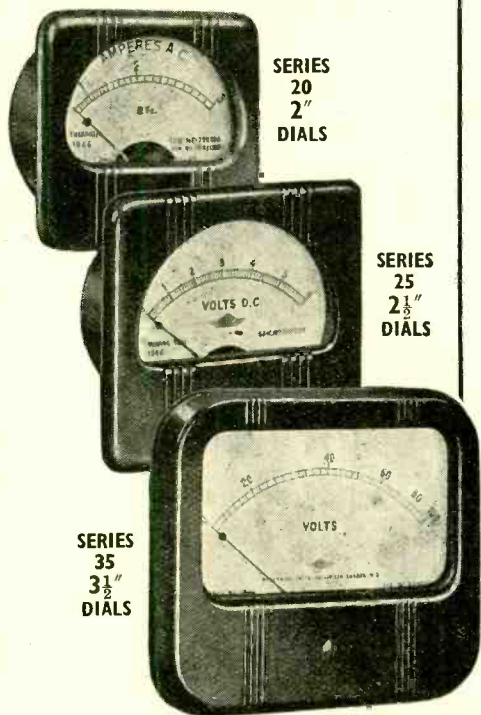

SERIES
20
2"
DIALS

SERIES
25
2½"
DIALS

SERIES
35
3½"
DIALS

PULLIN MINIATURE INSTRUMENTS

We can give early delivery—write for details.



MEASURING INSTRUMENTS (PULLIN) LTD

Address all enquiries to Dept. J, Electrin Works, Winchester Street, Acton, London, W.3. Telephone: Acorn 4651-4

KOLECTRIC

AUTOMATIC COIL WINDING MACHINE

TYPE A1/1

This machine is the most modern on the market and it possesses many exclusive refinements including :

- *Dustproof construction throughout.*
- *Provision for winding up to four coils simultaneously.*
- *Micrometer traverse setting.*
- *Wire Gauge Indicator engraved with various wire gauges to which the machine can quickly be set.*
- *Instantaneous reset counter reading up to 100,000 Turns.*
- *Entirely new Wire Tensioning Stand to hold two reels of wire.*

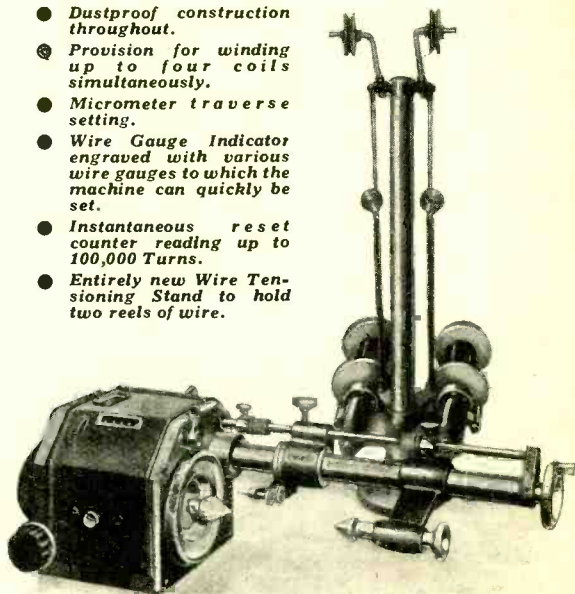

We will be pleased to send you an illustrated leaflet giving a full technical specification, on request.

KOLECTRIC LTD

20, AVONMORE RD.

LONDON · W-14

Telephone : Fulham 4211/2.

TELCON THERMOSTATIC BIMETALS

**A COMPLETE RANGE
NOW AVAILABLE
TO MEET ALL
REQUIREMENTS**

PHYSICAL CHARACTERISTICS OF AVAILABLE TYPES

TYPE	COMPOSITION		Deflection Constant* per °C. (d)	Resistivity microhms/cm. cube at 20°C.	Maximum Working Tem. °C.
	Low Expansion % Ni	High Expansion % Ni			
BIMETAL 140	38	20	14.0 x 10 ⁻⁶	75	300
BIMETAL 160	36	20	15.6 x "	78	250
BIMETAL 400	42	20	11.0 x "	70	400
BIMETAL 15	36	100	9.7 x "	15	200

* The deflection constant (d) is defined as the deflection of a strip of unit length and unit thickness for each °C. rise in temperature over the linear part of the deflection curve.

Further details on application.



THE TELEGRAPH CONSTRUCTION & MAINTENANCE CO. LTD.

Head Office: 22 OLD BROAD STREET, LONDON, E.C.2. Telephone: LONdon Wall 3141
Enquiries to: TELCON WORKS, GREENWICH, S.E.10. Telephone: GREenwich 1040

Simple Arithmetic

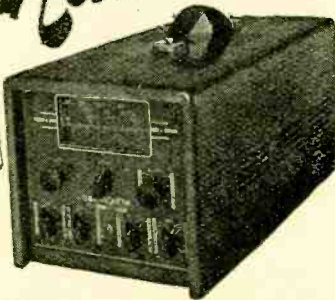

THE GRAMPIAN 461 RECEIVER AMPLIFIER

This new high-grade reproducer has been specially designed for use in Small Factories, Hotels, Clubs, Swimming Pools, Municipal Buildings, etc., where it is desired to broadcast Radio or Gramophone Records and provide amplification of speech by use of a microphone. Let us send you further details.

A dual wave-band superheterodyne with Power Amplifier having an output of 15 watts. Provision is made for both pick-up and microphone inputs with separate volume controls and high and low impedance outputs. It is of extremely robust construction in an attractively finished metal case.

Price List £42 0 0
Plus £2 2 0
Purchase Tax
A.C. Mains ONLY

GRAMPIAN LOUDSPEAKERS

GRAMPIAN REPRODUCERS LTD.
Hampton Road, Hanworth, Middlesex. Phone: Feltham 2657

HAVE YOU HAD
DETAILS OF OUR
NEW LINES?

Scientific G.6A.

SYLMAR RADIO LTD. BARGAINS

All articles are new and guaranteed and are of well-known manufacture.

- Two-gang .0005 Condensers 8/6
- Mains Transformers :
280-0-280 v. 6.3 v. 3 amp. 5.0 v. 2 amp. 20/-
- 60 m/a Chokes, 400 ohms. 5/6
- 465 Kc. I.F.'s, iron dust cored, permeability tuned, 1 1/2 in. x 1 1/2 in. can pr. 15/6
- Midget I.F.'s, iron dust cored pr. 15/6
- 7 m/cs I.F.'s pr. 5/-
- GRAMOPHONE AMPLIFIER KITS, 4 watts output, including 2nd detector and A.V.C. components. All parts mounted. Complete with circuit. A.C. £3
- Gramophone Amplifier Kits as above, AC/DC... .. £3

GOVERNMENT SURPLUS OFFERS

- .1 mfd. 350 v. Condensers doz. 4/6
- .1 mfd. 1,000 v. Condensers doz. 6/6
- .1 x .1 x .1 Condensers, 250 v. doz. 9/-
- Octal Valveholders 4/d.
- Mazda type Valveholders 3/d.
- 32 mfd. 275 v. 3/9
- 5in. P.M. Speakers 12/6
- 6in. P.M. Speakers with trans. 15/6
- 2in. Drums 1/-
- 3-pole 2-way Switches, long spindles 2/-
- 16 x 8 450 v. working Cond. 7/6
- 8 x 8 450 v. working Cond. 6/6
- Clips for above 3/d.
- Vibrator Pack. 12 v. Input 210 v. 70 m/a output. Special price to clear 25/-
- 3-way .3 amp. Line Cord, 60 ohms per foot... .. yd. 1/6
- Terms : Cash with Order or C.O.D. Post Orders only, carriage and packing extra.
- Retailers' enquiries for above welcomed.

SYLMAR RADIO LTD.
197, Lower Richmond Road, Richmond, Surrey

Wharfedale

Twin Speaker CORNER CABINET
With Bass and Treble Reflex Chambers

Height 42", Width 25½", Depth 18½". Impedance 6 or 15 ohms, without Transformer. Cabinet in Walnut or Mahogany.

Sets a new Standard in life-like reproduction. Fitted with W1c/CS unit for the Treble and W12/CS for Bass, with the new Wharfedale Separator and Dual Controls. The Bass resonance is 35/40 CPS and wide diffusion of high notes is achieved. Maximum input 10 watts.

Demonstrations at:

- | | |
|---|---|
| LONDON.—Webb's Radio, 14, Soho St.,
W.I. Universal Electronic Products, 36,
Marylebone High St., W.I. Wallace
Heaton Ltd., 127, New Bond St., W.I. | COVENTRY.—A. & F. E. Hanson Ltd.
HALIFAX.—Radio Equipment (Yorkshire)
Ltd.
HUDDERSFIELD.—Radio Equipment (York-
shire) Ltd.
LEICESTER.—G. W. Cowling Ltd.
LIVERPOOL 3.—Rushworth & Dreaper Ltd
SHIPLEY.—Excel Services.
WALSALL.—H. Taylor & Son.
WORTHING.—Barnes & Spicer, Chapel St |
| BIRMINGHAM 8.—R. F. Sweeney & Co.
BIRMINGHAM 2.—Scotchers Ltd.
BRADFORD.—Radio Equipment (York-
shire) Ltd. J. Scurrah & Son, Bankfoot. | |
| BRIGHTON.—Brighton Radio
Circuit Ltd., 77, Grand Parade. | |

PRICE £48 - 10 - 0

Made and Guaranteed by:

WHARFEDALE WIRELESS WORKS

BRADFORD ROAD - IDLE - BRADFORD

Telephone : IDLE 461. Telegrams : Wharfdel, Idle, Bradford



A UNIQUE INSTRUMENT

90 RANGES & 20,000 OHMS PER VOLT ON A.C. & D.C.

MODEL 85A

PRICE - - - £19 19 0

H.P. TERMS: £1 19 0 deposit and
11 monthly payments of £1 18 2

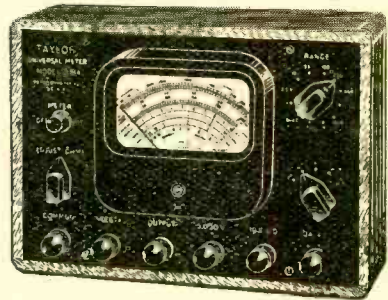

IMMEDIATE DELIVERY

- TAYLOR PRODUCTS INCLUDE: MULTIRANGE A.C. D.C. TEST METERS ● SIGNAL GENERATORS ● VALVE TESTERS ● A.C. BRIDGES ● CIRCUIT ANALYSERS ● CATHODE RAY OSCILLOGRAPHS ● HIGH AND LOW RANGE OHMMETERS ● OUTPUT METERS ● INSULATION TESTERS ● MOVING COIL INSTRUMENTS

TAYLOR ELECTRICAL INSTRUMENTS LTD

419 - 424 MONTROSE AVENUE, SLOUGH, BUCKS, ENGLAND

Telephone SLOUGH 21381 (4 lines)

Grams & Cables "TAYLINS" SLOUGH

RM

Radio Feeder

483

Designed to supply radio signals to all classes of amplifiers. Three wave bands. Output 5 volts across 680K-ohms. Three valves 6K8G, 6K7G, 6Q7G. Price £12 12s. plus £4 1s. 10d. purchase tax.

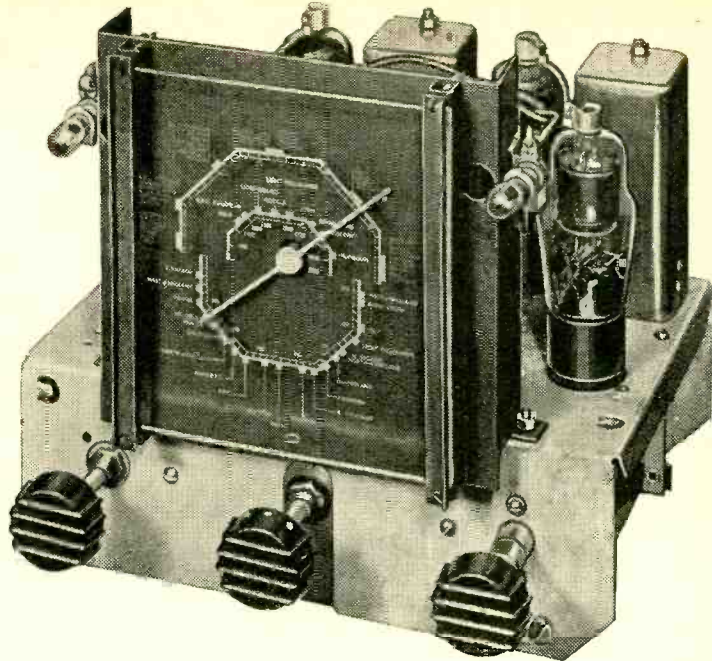

Send for full particulars.

R. M. ELECTRIC LTD., TEAM VALLEY, GATESHEAD, II.

Rothermel BRINGS CRYSTAL REPRODUCTION WITHIN THE REACH OF ALL

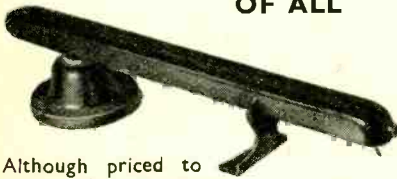

MODEL
U/48

Although priced to meet the more slender purse, the new U/48 Crystal Pick-up is an instrument designed to give high quality reproduction, since it embodies many features found in the more expensive models which include

- Extremely light weight. No record wear.
- Fully screened streamlined tone arm.
- New type of torsional crystal element.
- Cartridge specially treated to withstand extreme humidity.
- Tone arm lifts to almost vertical position for easy needle changing.
- Negligible tracking error.
- Finished in attractive brown cellulose.

Remember, the U/48 is backed by many years of experience and development in the application of the piezo electric crystal to sound reproduction by the House of Rothermel, and modern methods of manufacture result in a high-class product at a low price.

PRICE 25/- complete with Needle Screw and Rest. Purchase Tax Extra.

If fitted with Rothermel Jewel Tipped Needle giving many hundreds of playings 31/-, Purchase Tax Extra.

R. A. ROTHERMEL LTD., CANTERBURY ROAD, KILBURN, LONDON, N.W.6
Telephone: MAIDA Vale 6066 (3 lines).



Manufacturers
of
LOUDSPEAKERS
●
LAMINATIONS
●
SCREENS
In
RADIOMETAL
●
PERMALLOY
●
SILICONALLOYS

ELECTRICAL SOUND & TELEVISION PATENTS LTD.
12, Pembroke Street, London, N.1. Terminus 4355
2/4, Manor Way, Boreham Wood, Herts. Elstree 2138



POTTED TYPE TRANSFORMERS

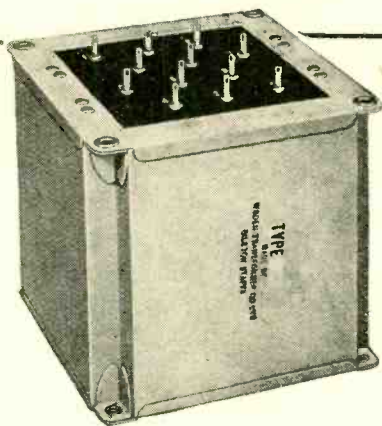

P.T.M.11	250-0-250	60m/a
P.T.M.12	275-0-275	120m/a
P.T.M.13	350-0-350	120m/a
P.T.M.14	425-0-425	150m/a
P.T.M.15	500-0-500	150m/a

The above ratings are standard type and are complete with either British or American voltage filament windings. Other and larger sizes available.

Potted transformers are particularly suitable for incorporating in equipment for tropical or home use, and enquiries are invited from manufacturers. Keen prices can be quoted for quantities.

We also welcome your enquiries for all types of Industrial Transformers up to 50 KVA.

WODEN TRANSFORMER CO LTD
MOXLEY ROAD, BILSTON
STAFFORDSHIRE

TELEPHONE: BILSTON 41959/0

J.T.L.50

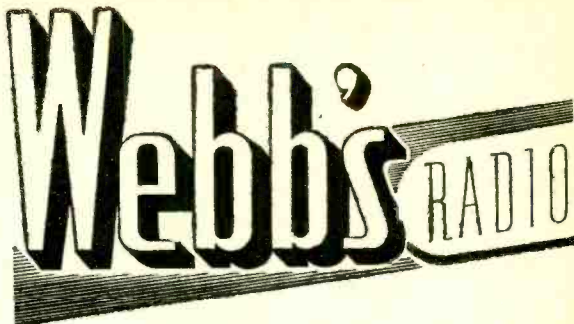

HIGH FIDELITY REPRODUCTION

We have some interesting additions to our range of Pick-ups, Reproducers, etc. We gladly demonstrate comparisons—why not bring a few of your own records and hear for yourself.

- VITAVOX "BITONE" No. 610.**
 A twin unit loudspeaker of outstanding merit, incorporating a 12in. unit for bass reproduction and a moving coil pressure unit with Duralumin alloy diaphragm for higher frequencies. An electrical dividing network ensures correct distribution of the frequency spectrum between the two units. PRICE... £42 0 0
- WHARFEDALE "CORNER CABINET."**
 Triangular cabinet construction of pleasing finish. Separate speakers for bass and treble with new cross-over system at 1,000 c/s. Very pleasing balance between bass and treble. PRICE... £48 10 0
- ACOUSTICAL "LABYRINTH S.L. 15."**
 Cabinet incorporates ingenious internal design giving equivalent of a five-foot folded pipe. Wide-response bass down to 35 c/s with good middle and top definition. PRICE... £19 10 0
- SOUND SALES "PHASE INVERTER SPEAKER."**
 Gives excellent diffusion of sound, cabinet design ensuring 180° phase-inversion and general effects are better than results obtained with a 4-foot baffle. PRICE... £14 7 6
- ACOUSTICAL AMPLIFIER "QA 12/P."**
 A 10 watt amplifier of compact design complete with pre-amplifier giving independent control of bass and treble. Push-pull output in specialized cathode-follower circuit. PRICE... £30 0 0
- WEBB'S "MC/QA" AMPLIFIER.**
 Based on "Wireless World" design with push-pull PX4's. Variable base compensation gives high fidelity reproduction from modern Pick-ups. PRICE... £35 0 0
- SOUND SALES "S.S. 6" AMPLIFIER.**
 Uses push-pull PX4's. Requires input of .5 volts for full output. PRICE... £15 16 3
- SOUND SALES "TC/1" TONE-CONTROL.**
 Combined pre-amplifier and tone-control, enabling "Sound Sales" amplifiers to be used with modern moving coil, etc., Pick-ups. PRICE... £11 7 9
- All "Sound Sales" domestic reproducing equipment normally in stock.
- BRIERLEY "RIBBON" PICK-UP.**
 A revised type of this highly specialized Pick-up with new unbreakable ribbon is now available. Record pressure 4oz. Output voltage 10 to 15 mV. PRICE: Including special Mumetal screened transformer... £10 2 4
- BRIERLEY "ARMATURE" PICK-UP.**
 Pressure 1/2 oz. Output voltage, 1 to 1 volt. Probably the best large output Pick-up that has yet been devised. PRICE: Including Mumetal Screened transformer... £8 15 9
- CONNOISSEUR "ARMATURE" PICK-UP.**
 Excellent engineering construction ensures reliability and consistent results. PRICE, with input transformer... £4 4 7
- WILKINS & WRIGHT "N" MOVING COIL PICK-UP.**
 A standard of comparison for moving coil units. Excellent mechanical and electrical design. PRICE, with input transformer... £7 13 4
- LEXINGTON "SENIOR" MOVING COIL PICK-UP.**
 Incorporates ingenious semi-automatic insertion and rejection of special sapphire needles. PRICE... £7 6 9
- LEXINGTON "JUNIOR" MOVING COIL PICK-UP.**
 For standard miniature needles. PRICE... £4 12 4
- LEXINGTON screened input transformer**... £1 13 2

You are invited to judge the difference in reproduction afforded by recent technical developments.

14, SOHO ST., OXFORD ST., LONDON, W.1
 Phone: GERrard 2089. Shop hours: 9 a.m.—5.15 p.m. Sats. 9 a.m.—1 p.m.

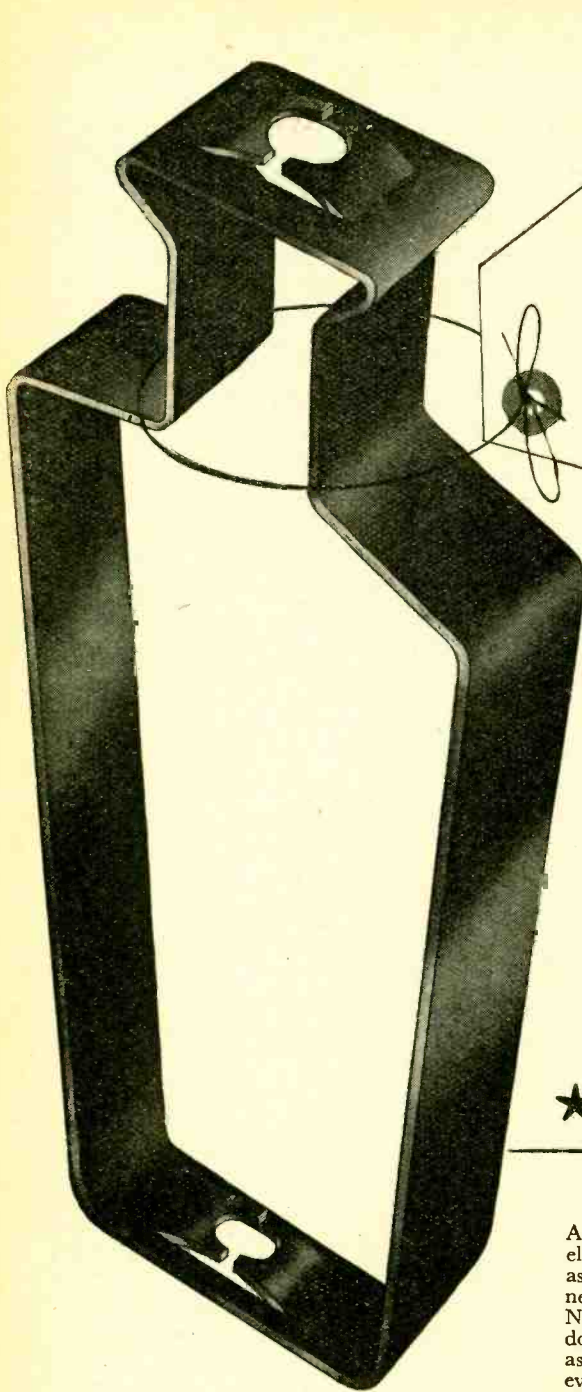

**Shake
vigorously**
(NOTHING HAPPENS)

Shake as much as you like and as long as you like. You won't shake a Spire fixing loose — it's double-locked. When the screw or bolt is screwed into the Spire Fix the two prongs close and grip the thread. Then the arched base is compressed making a self-energised spring lock which still further tightens the grip on the thread. A Spire Fix holds just as tightly on an unthreaded stud. Spire fixings are light and simple but they are strong medicine. Can we make up a "prescription" for any of your light assembly problems?

Spire
Regd.

★ A BETTER way of fixing

THAT'S fixed THAT!

A Boiler maker uses this Spire fixing. $\frac{3}{16}$ " studs are electrically welded to the exterior of boiler plates; asbestos sheets are pierced and placed over the pins; next a mild steel washer, and then the Spire Fix No. SV1628 is pushed quickly down the stud to make a snug assembly which will hold for ever and a day but is sufficiently elastic to ensure that the asbestos sheets do not crack. All assembly is carried out from the exterior — a material saving in time and cost.



Valve replacements - hard to get *BRIMARIZE! - a working set

TYPE 84/6Z4 is a full wave rectifier, very popular in pre-war car radios. Type 6X5G will make a satisfactory replacement and in 6 volt receivers, only a change of socket is required.

In 12 volt receivers, the heaters of the 84/6Z4 and one of the other valves are usually connected in series across the 12 volt supply, a resistance being fitted across one of the heaters to equalise the currents in the two valves. When a 6X5G is used the value of this resistor must be reduced.

PUNCH HOLES HERE

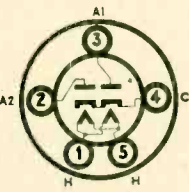
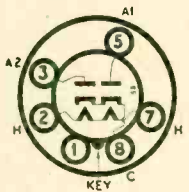
 <p>84/6Z4</p>	 <p>6X5G</p>	<p>CHARACTERISTICS</p> <table border="1"> <tr> <td></td> <td style="text-align: center;">84/6Z4</td> <td style="text-align: center;">6X5G</td> </tr> <tr> <td>Heater Voltage</td> <td style="text-align: center;">6.3</td> <td style="text-align: center;">6.3 volts</td> </tr> <tr> <td>Heater Current</td> <td style="text-align: center;">0.5</td> <td style="text-align: center;">0.6 amp.</td> </tr> <tr> <td>R.M.S. Input</td> <td style="text-align: center;">325</td> <td style="text-align: center;">325 volts</td> </tr> <tr> <td>Rectified Current</td> <td style="text-align: center;">60</td> <td style="text-align: center;">70 mA.</td> </tr> </table>		84/6Z4	6X5G	Heater Voltage	6.3	6.3 volts	Heater Current	0.5	0.6 amp.	R.M.S. Input	325	325 volts	Rectified Current	60	70 mA.
	84/6Z4	6X5G															
Heater Voltage	6.3	6.3 volts															
Heater Current	0.5	0.6 amp.															
R.M.S. Input	325	325 volts															
Rectified Current	60	70 mA.															

TYPE	CHANGE SOCKET		CHANGE CONNECTIONS		OTHER WORK NECESSARY	PERFORMANCE CHANGE
	FROM	TO	FROM OLD SOCKET	TO NEW SOCKET		
6X5G	U.X. 5 PIN	INT. OCTAL	PIN 1 " 2 " 3 " 4 " 5	PIN 2 " 3 " 5 " 8 " 7	6 volt sets—None. 12 volt sets— Change value of balancing resistor if fitted (see Note)	NONE

Note.—The value of this resistance in ohms is found by dividing 6.3 by the difference in heater current (expressed in amps.) of the two valves which are in series. e.g.—A type 41 (heater current 0.4 amp.) will require a parallel resistance of value $\frac{6.3}{0.2} = 32$ ohms when connected in series with a 6X5G across a 12 volt supply.

BRIMARIZING . . . A scheme devised by BRIMAR for keeping repair lines on the move, a means whereby radio sets may be kept working happily in the home and not waiting on the shelf.

BRIMAR RADIO VALVES

STANDARD TELEPHONES AND CABLES LIMITED, FOOTSCRAY, SIDCUP, KENT.

A SERVICE PLAN FOR PLANNED SERVICE

84/6Z4

INSTRUCTIONS: Punch holes where indicated, cut away this portion and file for reference guide.

13

WE'D LIKE YOU TO KNOW —

simplicity WITH efficiency

IN FERRANTI TELEVISION

A major problem in the designing of television receivers has been to make satisfactory provision of scan generators — and more particularly, the horizontal scan generator.

By making use of a number of valves the problem had been simplified somewhat, but it still has been the aim of designers to evolve the single valve generator. For a solution on these lines would not only lead to economy in design, but should result in really efficient operation. Ferranti television engineers have found a solution to the problem, and the single valve line time base is now an accomplished part of a Ferranti television circuit.

In practice it has proved that the single valve generator has a number of advantages over the conventional two valve generator. For instance, the grid behaves as an "efficiency diode" and gives 25% more power than the class "A" operated amplifier.

Again, owing to its highly inductive anode load the generator possesses inertia which can be likened to a flywheel in that it makes for stability, enabling synchronism to be held throughout the worst interference.

The biggest disadvantage resulting from the use of the single valve generator is the interdependence of controls, for it is difficult to control the amplitude without affecting the frequency. This difficulty, however, has been successfully overcome in the

Ferranti circuit by a unique design. In this, the screen grid in a triode operated tetrode valve has been used to control the amplitude quite independently of frequency.

Thus, the single valve line time base generator is simplicity itself. And, as the number of components used is at a minimum, so set reliability is enhanced.



MODEL 1146 in bleached walnut and ebonised cabinet, with 7½" x 6" screen. High quality sound and vision performance. Vibrationless chassis mounting. Two-knob control. A.C. Mains only. Price £95.11.9 (inc. £24.1.9 tax).

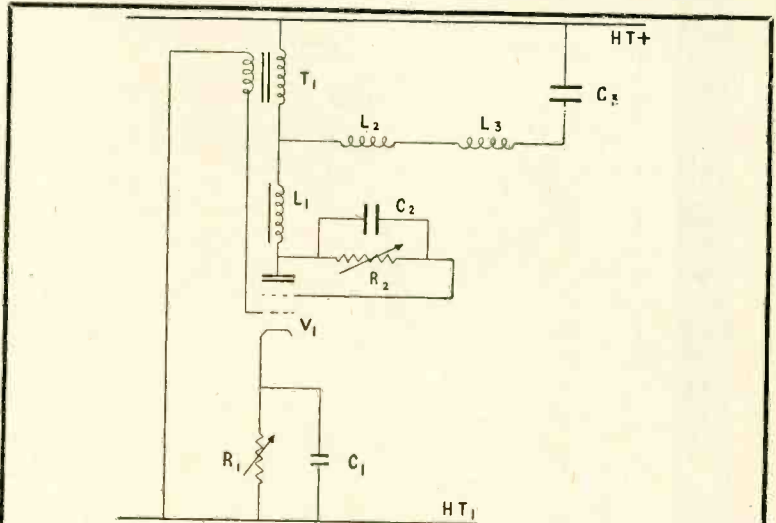

TECHNICAL EXPLANATION

The scanning coils L2 and L3 provide an inductive load in the anode circuit of the valve V1. With the valve A.C. resistance, the circuit becomes an inductance and resistance in series. At the instant of switching on the H.T., current flows through this circuit increasing in value at a rate determined by the time constant of the circuit. To obtain a linear current change through the coils, the time constant must be much longer than the single stroke time. This is achieved by using scanning coils with a high inductance and a valve with a low A.C. resistance. The oscillatory action is obtained by

coupling the grid into the anode circuit, the frequency being controlled by R1 which determines the bias applied to the grid circuit. During part of the cycle, grid current flows, its direction being such that energy is restored to the scanning circuit, thereby improving the efficiency.

To linearise the trace, the choke L1 is included in the anode circuit. This choke saturates during the scanning stroke, modifying the rate of change of current through the scanning coils from an exponential to a linear trace. The amplitude of the current change is controlled by the potentiometer R2 shunted by the condenser C2.



Ferranti Ltd

MOSTON MANCHESTER 10; & 36 KINGSWAY LONDON WC2

THE "BELLING-LEE PAGE"

Providing technical information, service and advice in relation to our products and the suppression of electrical interference

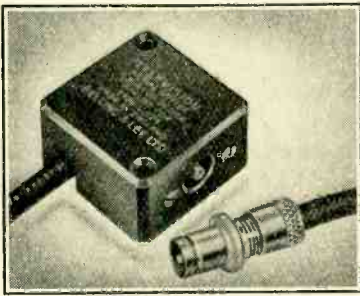

*1. Television outlet box L624.

TELEVISION OUTLET BOX

The Belling-Lee television coaxial outlet box L624*1 (illustrated above) is for skirting board termination of 1/4 in. to 1/2 in. diameter coaxial feeders (Uniradio 32 or "Belling-Lee" L600*6) and the outlet socket will take any of our new range of coaxial plugs.

The metal braiding of the incoming feeder is connected between the cable clamp and casing, while the inner conductor is taken to a screw terminal on the central stem of the output socket.

BURNT-OUT "ELIMINOISE" TRANSFORMERS

As we have had a few more cases of these transformers being returned to us "burnt-out" we feel no apology is required for repeating question and answer No. 36 which appeared in "Wireless World," March, 1947.

When a transformer does "burn-out" in this way, we can accept no responsibility, as any aerial would become alive in the same circumstances and therefore the receiver is in a very dangerous condition and should not be used until the isolating capacitor has been replaced by a dealer.

Question 36: Can an "Eliminoise" receiver transformer be "burnt-out"?

Answer 36: It is surprising how many people in the trade—and out of it—do not realise that this can happen until the possibility is pointed out to them—then the reason seems obvious. It invariably happens with AC-DC sets, in which the design allows the chassis to be alive at mains voltage, with respect to earth. If an earth terminal is fitted, it should be connected to chassis via a capacitor, thereby isolating the

chassis. Unfortunately, some manufacturers omit the earth connection altogether; in other cases the earth capacitor breaks down.

When an "Eliminoise"*4 aerial is used in these circumstances, the receiver "Eliminoise" transformer is earthed. If there is no capacitor (or one that has broken down) between earth and chassis, or between aerial and chassis, current from the chassis flows through the "Eliminoise" coil and may burn it out.

Unfortunately, there are AC-DC sets where the aerial becomes alive through the same cause, and should the aerial fall down on a garden or metal clothes line, the results might be disastrous.

AIRCRAFT AND TELEVISION

It is now generally known that a television signal can be reflected from an aircraft flying in the vicinity of a domestic viewer, and that the resulting "echo" appears on the television tube as an interference in the form of a flutter.

We have learnt that the "Belling-Lee" Inverted "V" television aerial L606*2 is particularly sensitive to this form of interference and therefore is not recommended for use in districts close to busy airfields where aircraft are continually making circuits. In such locations a simple dipole such as L501*5 or preferably dipole and reflector L502 is to be recommended.

IGNITION INTERFERENCE SUPPRESSORS

The "Belling-Lee" suppressor L630*3 (shown above) is designed to obviate car ignition interference with television and to fit in the H.T. lead from coil to distributor.

The use of this suppressor eliminates the cutting of the lead, by screwing into most makes of distributor caps or coil cans after the H.T. Lead terminal has been removed. The latter is then screwed into the top of the suppressor.

With distributors or coils where the screw-in connections are not employed a different suppressor is required, type L1274. With this type the H.T. lead has to be cut, preferably near the distributor, and the cut ends then screwed into the ends of the cylindrical suppressor. No tools are required other than that to cut the lead.

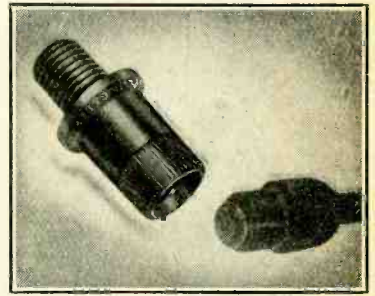

*3. A new version in ignition interference suppressors L630 manufactured by Belling & Lee Ltd., designed to fit in "distributor caps" or "coil cans." List Price 1/6 each.

Wholesalers, retailers and manufacturers can do a lot towards helping the campaign to suppress car interference, by making provision for their own employees and customers to fit suppressors to their cars. All "Belling-Lee" vehicles and those owned by our employees have been dealt with, and we understand that the B.B.C., R.I.C., and many publishers of motor and radio trade journals have done likewise.

The success of television may be seriously affected if potential television viewers encounter car ignition interference at the time of demonstration, and it should be made known to those that object (not being owners of television sets) to fitting a 1/6 suppressor to their cars, that any improvement in television reception will increase its popularity, create a greater demand for sets and bring down the prices, making everybody a potential buyer.

It is the task of the Industry to do everything possible to aid the campaign.

- *1. Television outlet box L624.
- *2. Inverted "V" aerial L606, £4 10s. For attic or loft L605, £2 12s. 6d.
- *3. A new version in ignition interference suppressors L630 manufactured by Belling & Lee Ltd., designed to fit in "distributor caps" or "coil cans." List Price 1/6 each.
- *4. "ELIMINOISE" Regd. Trade Mark, L308/K, £6 6s.
- *5. "VIEWROD" Regd. Trade Mark.
- *6. L600, 1/6 per yard.

BELLING & LEE LTD
CAMBRIDGE ARTERIAL ROAD, ENFIELD, MIDD



FOR FREQUENCY SUB-STANDARDS

TYPE JCF/200, 100 KC/S
Available from stock adjusted to $\pm 0.01\%$
Higher accuracies supplied to special order
PRICES ON APPLICATION

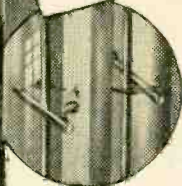

V WIREMOUNTING
BRITISH PATENT NO 578290

The type JCF/200 unit illustrated above is representative of the wide range of vacuum type units available for low and medium frequencies.

G.E.C.

QUARTZ CRYSTAL UNITS

FOR STABLE FREQUENCY GENERATION

FEATURES:

Low temperature coefficient—less than 2 in 10^6 per °C. Patented nodal suspension. Mounted in vacuum; performance independent of climatic conditions. Exceptionally high Q value. High stability. Small size, 3in. x $\frac{5}{8}$ in. overall excluding pins. Fits standard miniature deaf aid valve socket.

SALFORD ELECTRICAL INSTRUMENTS LTD.
PEEL WORKS SALFORD 3
Phone: BLA. 6688 (6 lines) Grams & Cables "Sparkless, Manchester"

Proprietors. THE GENERAL ELECTRIC CO. LTD. England.

Vortexion

C.P.20A

15 WATT AMPLIFIER

for 12 volt battery and A.C. Mains operation. This improved version has switch change-over from A.C. to D.C. and "stand by" positions and only consumes 5½ amperes from 12 volt battery. Fitted mu-metal shielded microphone transformer for 15 ohm microphone, and provision for crystal or moving iron pick-up with tone control for bass and top and outputs for 7.5 and 15 ohms. Complete in steel case with valves.

As illustrated. Price £28 0 0

A.D. 47 10-valve Triode Cathode Follower AMPLIFIER

for this recording and play-back amplifier we claim an overall distortion of only 0.01% as measured on a distortion factor meter at middle frequencies for a 10 watt output. The output transformer can be switched from 15 ohms to 2,000 ohms, for recording purposes, the measured damping factor being 40 times in each case. Full details on request.

- "SUPER FIFTY WATT" AMPLIFIER complete in case. Price 36½ Gns.
- RECORD REPRODUCER AMPLIFIER complete in case. Price 25½ Gns.
- "THIRTY WATT" AMPLIFIER complete in case. Price 30½ Gns.



EXPORT ENQUIRIES INVITED

VORTEXION LTD.

257-261 THE BROADWAY, WIMBLEDON, S.W.19

Telephones: LIBerty 2814 and 6242/3

Telegrams: VORTEXION, WIMBLE, LONDON



PHILIPS

SOUND AMPLIFYING EQUIPMENT

for every purpose

British made to an exacting tropical specification. Most standard items available from stock. Enquiries invited

from Dealers and Wholesalers. If you need sound equipment, write or 'phone the Amplifier Sales Manager,



PHILIPS ELECTRICAL

LIMITED

AMPLIFIER DEPARTMENT, CENTURY HOUSE, SHAFTESBURY AVENUE, W.C.2
Telephone: GERrard 7777

April is a notable month

first All-Fools' Day, then the Budget

WE MAY NOT KNOW WHAT IS IN STORE FOR US, BUT WE CAN BE CERTAIN OF QUALITY WITH "SOUND SALES"

FOR RELAXATION

THE ELECTROGRAM with finger tip electronic tone controls.

THE PHASE INVERTER SPEAKER, which led the field in acoustic cabinet devices — and is still leading.

FOR HOME CONSTRUCTION and built-in Radio

FEEDER UNITS.

D.X. PLUS SEVEN QUALITY CHASSIS.

TONE CONTROL UNITS.

INHERENTLY BALANCED PUSH-PULL QUALITY AMPLIFIERS from 6W to 50W.

TRANSFORMERS AND CHOKES of all types.

FOR INDUSTRIAL PURPOSES

BATTERY CHARGERS.

FACTORY SOUND INSTALLATIONS including the new Auto-call System.

RACKS AND PANELS.

AGENTS :

Barnes & Avis, Reading; Bowers & Wilkins, Worthing; Binns Ltd., Newcastle; Dalton & Sons, Ltd., Derby; Clark & Sons, Isle of Wight; Hickie & Hickie, Ltd., Reading (and branches); Thomas Lynn & Sons, Andover; Merriots Ltd., Bristol; Needham Engineering Ltd., Sheffield; Pank's Radio, Norwich; Sound Ltd., Cardiff; Bernhard Smith, Barnstaple; Sound Services, Jersey, C.I.; Precision Services, Edinburgh; Seals Ltd., Southsea; G.E. Samways, Hazel Grove; Weybridge Radio Electric, Weybridge; West End Radio, Farnham; Vallance & Davison, Ltd., Leeds (and branches).

Overseas Stockists in :

Canada, South Africa, Channel Islands, etc.

When you see the word "SOUND" think of

Sound Sales Ltd.

57, St. Martin's Lane, London, W.C.2

(TEMPLE BAR 4284)

WORKS: Farnham, Surrey. (FARNHAM 6461/2/3)

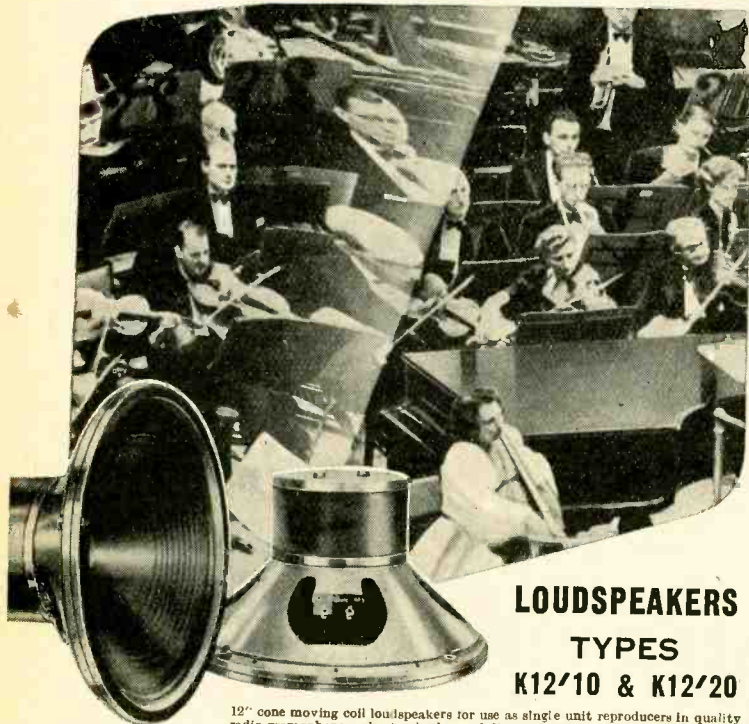

ELIMINATE SOUND DISTORTION

Can distortion be eliminated? Not quite, of course, but it can be reduced to a minimum by the use of loudspeakers which will introduce as little discoloration as possible—well designed loudspeakers—Vitavox loudspeakers in fact.

LOUDSPEAKERS TYPES K12'10 & K12'20

VITAVOX

MANUFACTURERS OF SOUND EQUIPMENT

12" cone moving coil loudspeakers for use as single unit reproducers in quality radio gramophone, sub-standard sound film equipment, or public address apparatus or as the low frequency section of a dual channel system, the K12'10 and K12'20 loudspeakers incorporate high efficiency ticonal magnets, accurately centred poles, and inter-changeable diaphragms impregnated to resist moisture.

Type	Power Handling Capacity	Total Flux	Impedance
K12'10	10 watts	140,000 lines	15 ohms
K12'20	20 watts	170,000 lines	15 ohms

VITAVOX LIMITED
Westmoreland Road, London, N.W.9.
Tele: COLindale 8671-3

1998

Quality

**ACKNOWLEDGED
THROUGHOUT
THE WORLD**



ERIE

Radio & Electronic Components

**RESISTORS · CERAMICONS · Hi-K CERAMICONS · POTENTIOMETERS
SUPPRESSORS : VITREOUS ENAMELLED WIRE-WOUND RESISTORS**

Erie Resistor Ltd., The Hyde, London, N.W.9, England
Telephone: COLindale 8011-4. Cables: RESISTOR, LONDON.
Factories: London & Gt. Yarmouth, England · Toronto, Canada · Erie, Pa., U.S.A.

E.M.I. TRAINING FOR CAREERS IN ELECTRONICS

ENROLMENT for an E.M.I. correspondence course, brings students into direct contact with scientists of Britain's Largest Electronic organisation.

BASIC RADIO and BASIC TELEVISION are specially recommended as fitting the student for such examinations as those of City & Guilds, Brit.I.R.E., etc., and give him a groundwork of knowledge on which to build a career in Electronics. Whatever course is chosen, the E.M.I. staff give not merely set lessons, questions and model answers, *but living*, first hand up-to-the minute knowledge of the application of electronics to industry.

In addition to the postal courses E.M.I. Institutes offers **FULL TIME COURSES** for those who can attend the College.

Write for full details of the above and other courses to :



The Principal : PROFESSOR H. F. TREWMAN, M.A. (Cantab),
M.I.E.E., M.I.Mech.E., M.Brit.I.R.E.

E.M.I. INSTITUTES LTD
Dept. 16; 43, Grove Park Rd., Chiswick, W.4
E.58

VIBRATORS for RELIABLE REPLACEMENTS

- HERMETICALLY SEALED.
- FULLY TROPICALLY TESTED.
- Proof against thermal mis-alignment of contacts.
- Tested for radio-frequency at -40Db at a reference level of 500 mW.

Entirely British in design and construction, and fully approved for Government Service equipment, W.E. Vibrators are ready for all your replacements. They are fitted as standard components by leading radio manufacturers.



WIMBLEDON ENGINEERING CO. LTD.
GARTH ROAD · LOWER MORDEN · SURREY
TELEPHONE : DERWENT 4814, 5010

C.R.C.2

AT YOUR REQUEST

THE NEW

Labgear Fault Tracer

with incorporated

MAGIC EYE INDICATION

is now in production,

permitting
EASIER

Resistance and Capacity Measurements together with **MORE RAPID** Signal Tracing from Aerial Socket to Loudspeaker.

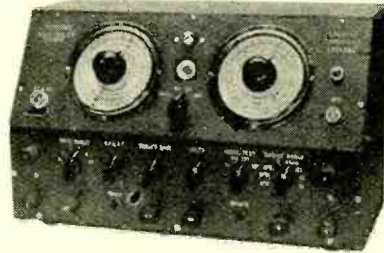

The Labgear Fault Tracer

COMBINES IN ONE COMPREHENSIVE INSTRUMENT ALL THE CHIEF TEST GEAR REQUIRED FOR YOUR SERVICE DEPT.

- | | | |
|-------------------|--------------------|---------------------|
| Resistance Bridge | ● Signal Generator | ● Capacity Bridge |
| H.T. Power Supply | ● Audio Oscillator | ● L.T. Power Supply |
| Insulation Tester | ● Signal Tracer | ● Voltage Indicator |

NOTE—In addition to Electronic Visual Indication, facilities for Aural Checking are still retained in this instrument.

Labgear, Ltd.

WILLOW PLACE, Phone: 2494 CAMBRIDGE

Fine tone RADIOGRAM from present GRAMOPHONE

easily and quickly made
IN THE HOME
with the

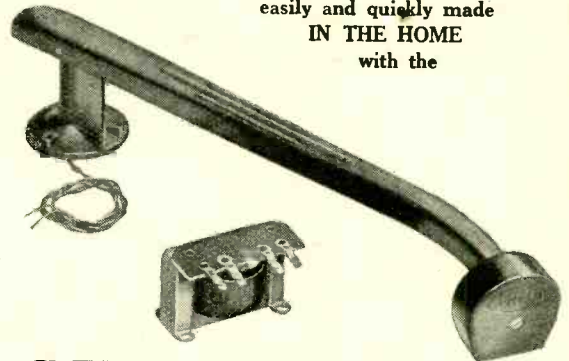

S.H.E.F.I. MOVING COIL PICK-UP

Voigt Patent No. 538058.

High fidelity without shielded transformer. No hum problem. Extreme lightness gives long record life. Complete with Transformer and full instructions. £2 plus Purchase Tax. De Luxe model now available with ball bearing suspension and spring counter-balance, £2.11.0 plus P.T.

EXPORT ENQUIRIES INVITED.

BROOKS & BOHM LTD.

90, Victoria St, London, S.W.1. Telephone: VICtoria 9550/1441

On a Generous Scale

In the new Marconi SIGNAL GENERATOR, TF 867, measurement facilities are on a 'generous scale'—including the frequency scale itself! In this one instrument such features are incorporated as crystal standardisation, freedom from unwanted frequency modulation, deep amplitude or carrier shift modulation and stabilised output level. Range is 15 kc/s to 30 Mc/s, and output variable from 4v to 0.4 μ V; calibration indicates true artificial signal e.m.f. irrespective of load.

An integral terminating unit offers source impedances of 75 Ω or 13 Ω and provides a dummy aerial; it also shows, on an animated diagram, the exact conditions of circuit. In all, and judged by any standard, Type TF 867 is demonstrably the very paragon of signal generators. Full particulars are freely available.



MARCONI INSTRUMENTS LTD

ST. ALBANS, HERTS. Phone: ST. ALBANS 6161/5

Northern Office: 30 ALBION STREET, HULL. Phone: Hull 16144 • Western Office: 10 PORTVIEW ROAD, AVONMOUTH. Phone: Avonmouth 438
Southern Office and Showrooms: 109 EATON SQUARE, LONDON, S.W.1. Phone: Sloane 8615



SIGNAL GENERATOR TYPE TF 867



that's JUST how it sounds on a **TRUVOX**

The cork is drawn, the party's on and you are there—there with all the gaiety that perfect reproduction can bring you. Truvox owners are getting extra realism that makes all the difference in listening to a favourite programme—Home, Light or Third. It has taken us 18 years to achieve it . . . it's yours today. A range of three extension cabinet speakers is in the dealers' shops already, "Monobolt" speaker chassis in four sizes are there too, you can hear them now. High fidelity pickups and "Wafer" speakers are well on the way. A postcard will bring full details.

MODEL BX55. The first of a new range of Truvox Extension Cabinet Speakers. This model incorporates 5in. Monobolt chassis, volume control recessed in side. Natural Birch cabinet, with contrasting chocolate coloured sides. List Price 65s.

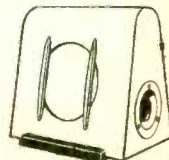

Truvox Engineering Co., Ltd., Truvox House, Exhibition Grounds, Wembley, Middlesex.

TX 27

A Wise Investment!



S. G. BROWN, Type 'K'
Moving Coil Headphones, with the following outstanding characteristics, supply that High Fidelity Reproduction demanded for DX work, monitoring and laboratory purposes, etc.

NOTE THESE CHARACTERISTICS.
D.C. RESISTANCE, 47 Ohms.
IMPEDANCE, 52 Ohms at 1,000 c.p.s.
SENSITIVITY, 1.2×10^{-12} Watts at 1 kc. = .0002 Dyne/cm².

Descriptive Literature on request.

TYPE "K." PRICE **£5.5.0** PER PAIR.

Supplies now available.

Order from your Local Dealer.

For details of other S.G. Brown Headphones (prices from 30/- to 63/-) ask for illustrated Brochure "V.W."

HEADPHONES WHICH UPHOLD BRITISH PRESTIGE.

Phone ACOrn 5021.

S.G. Brown, Ltd.

VICTORIA RD., NORTH ACTON, LONDON, W.3



Products of
Quality & Reliability

MAINS TRANSFORMERS
A. F. TRANSFORMERS
THERMAL DELAY SWITCHES
SMOOTHING CHOKES
POWER RESISTANCES.

Made by

OLIVER DELL CONTROL LTD

Telephone: WOOLWICH 1422-1425
CAMBRIDGE RDW • WOOLWICH • S.E.18



STABLE
to



Resistors produced by the cracked carbon process remain stable to $\pm 1\%$ of initial value.

★Tolerance $\pm 1\%$
 $\pm 2\% \pm 5\%$

Low temperature co-efficient.

Welwyn carbon resistor

WELWYN ELECTRICAL LABORATORIES LTD.
Welwyn Garden City, Herts. Telephone: Welwyn Garden 38168

7TH SALE

G. R.

By Order of the Minister of Supply—WITHOUT RESERVE

ASHCHURCH, GLOS.

(Within 2 miles of Tewkesbury and 7 of Cheltenham)

Sale by Auction

A Large Quantity of GENERAL STORES

including: Electrical Equipment. Photographic Chemicals, Paper and Accessories. 149 Electric and 8-Day Clocks. Large Quantity of Cycle Spares, etc. Camouflage Nets. Weighing Machines and Weights. 50 Steel Frame Shelters. Drawing Office Equipment, IMPING Boards, Tracing Tables, Inks and Paper. Sack Trucks. Hand Tools, etc.

Auctioneers:

BRUTON, KNOWLES & CO.

in conjunction with **GEORGE HONE**

SALE DAYS:

Wednesday, Thursday, and Friday, MARCH 31st, APRIL 1st and 2nd

and

Tuesday, Wednesday, Thursday and Friday, APRIL 6th, 7th, 8th and 9th, 1948

at 11 o'clock punctually each day.

VIEW DAYS: Tuesday, 30th March and Monday, 5th April. From 10 a.m. to 4 p.m., and on Sale Days from 9 a.m. to 10.45 a.m. CATALOGUE covering complete sale, price 6d. (postal orders ONLY) may be had of the Auctioneers, Bruton, Knowles & Co., Albion Chambers, Gloucester, (Tel. Gloucester 2267), or of George Hone, Tewkesbury, (Tel. Tewkesbury 2110).

NOTE: Applications for catalogues to be sent in envelopes marked ASH, top left hand corner.

ADMISSION WILL BE BY CATALOGUE ONLY.

"You're CERTAIN to get it at ARTHURS!"

VALVES: We have probably the largest stock of valves in the country.

AVOMETERS:

AVOMETER, Model 7	£19 10 0
AVOMETER, Model 40	£17 10 0
VALVE TESTER (Complete)	£16 10 0
TEST BRIDGE	£11 0 0
AVOMINOR, Universal Mod.	£8 10 0
SIGNAL GENERATORS	£13 0 0

TAYLORS' METERS. NOW IN STOCK.

Arthur's
ARTHUR GRAY, LTD.

LONDON'S OLDEST LEADING RADIO DEALERS

Only Address

GRAY HOUSE, 150, CHARING CROSS ROAD, LONDON, W.C.2

Telephone: TEMple Bar 5833/4

New Models Available

By extending the range of Lustraphone Moving-Coil Microphones, users anxious to obtain the best instrument for the

job will find in these models everything they want in terms of good reproduction and lasting dependability.



MOVING-COIL MICROPHONES

Leaflet from:

LUSTRAPHONE LIMITED

84, Belsize Lane, London, N.W.3
Telephone: Hampstead 5389 and 5515

Rate 6/- for 2 lines or less and 3/- for every additional line or part thereof, average lines 5-6 words. Box Numbers, 2 words plus 1/-. Press Day: May 1948 issue, first post Wednesday, April 7th. No responsibility accepted for errors.

WARNING

Readers are warned that Government surplus components which may be offered for sale through our columns carry no manufacturer's guarantee. Many of these components will have been designed for special purposes making them unsuitable for civilian use, or may have deteriorated as a result of the conditions under which they have been stored. We cannot undertake to deal with any complaints regarding any such components purchased.

NEW RECEIVERS AND AMPLIFIERS

H.P. RADIO SERVICES, Ltd., offer:-

H BRAND new ex-R.A.F. 5-valve battery superhet receivers complete with valves (types VP23, FC2a, HL2, PM2A), 3 wavebands, 33-300m. Muirhead dials, two output jacks; uses separate speaker or 'phones; requires ordinary 120v h.t. and 2v 1t. to operate (no 'phones or i.s. included). Grey finish, wooden cabinet, outstanding performance. Desirable in massive crate per passenger train, £5/10, carr. paid. Brand new Canadian 58 Mark I transceivers, 33-50 metres, 10gns; complete with two sets of 'phones and two mikes, three aeralis but no h.t. battery. By the time this advert. appears we expect to have suitable vibrator packs at 55/- New power packs, high cycles, 115v; brand new and unused; contain four 5R4 valves, numerous high voltage smoothing condensers, etc.; offered at half the price of the valves alone, 30/- each, carriage 5/- Milliampereters, 21p round panel mounting; full scale deflection 1 mA. Precision moving coil instrument, only 5/- each, post 9d. These meters are new and unused in sealed cartons. Ex-Govt moving coil headphones and moving coil hand microphones, slightly soiled but tested and guaranteed perfect, 9/6 set, post 10d. We are expecting further supplies of R107s and BC348s at our usual competitive prices. Is your name on our mailing list?—H.P. Radio Services, Ltd., 55, County Rd., Liverpool, 4. Tel. Aintree 1445. Estab. 1935.

EKCO U29X, export models, 11-35, 35-100, £20/4 550 metres. EF39, CCH35, EF39, CBI31, CY31, new, maker's guarantee; 17gns.—Maxey, Palace Ave., Paignton, Devon. (19301)

12 WATT W.W.Q. amp., new; £15; if you are can help you with components, valves, chassis, speakers, advice.—Mortimer & Domahue, 17, Rectulver Rd., S.E.16. Ber. 3629. (19346)

5-WAVEBAND receivers with gram mounting, gram units, grams, amplifiers, 5-500 watts; why not try us? We always try to help; s.a.e. for list to Mason's (W.W.). Wivenhoe, nr. Colchester. (12) v.c. battery, portable, suitable for car installations, general p.a. work, etc., £14 each or £30 the three.—A. E. Cawkell, 7, Victory Arcade, The Broadway, Southall, Middx. (19309)

3 PARMEKO 10watt amplifiers, complete with microphones, spares include valves, portable (12 v.c. battery, portable, suitable for car installations, general p.a. work, etc., £14 each or £30 the three.—A. E. Cawkell, 7, Victory Arcade, The Broadway, Southall, Middx. (19309)

19 48 leader units.—Complete range of aligned and calibrated feeder units with accurately printed station named scales; model A3, s.m.l. wave frequency changer and i.f. stage; model B3, s.m.l. wave, r.f. stage, f.c., i.f., and double diode triode; model B5 de luxe, 3 short-wave bands, m.l., 15inX4 1/2in scale, Magic Eye.—Send 2/4d. stamp for illustrated brochure to sole distributors, Coulphone Radio, 58, Derby, Ormskirk, Lancs. (19343)

R.A.F. responder units, complete with 4 mains H.F. pentode valves, 3 Mazda diodes, 2 twin triode mains valves and 1 EF50 Mullard; also includes 24v motor generator, suitable for modification to universal motor, 2 magnetic relays, several mechanical multi-contact relays; includes resistances, condensers, variable and fixed, and other useful components; 35/- each, carriage paid.—Uncle Tom's Radio Cabin, 5, Seven Stars Court, Manchester, 4. (19623)

SPECIAL offer: Midget communication receiver and power pack (M.C.R.1) 5-valve superhet, complete with aerial and earth equipment, lightweight headphones, range 20-3,000 metres in four bands, operates on any voltage between 97 and 250 a.c. or d.c., £9/10; send for one now before stocks are exhausted; another special offer, slow motion drives by Muirhead, 50-1 ratio, 10/- ea, postage 6d; also instrument rectifiers, 5ma, 7/6; I.P.P. units, complete with 10 useful valves, SP.41, etc. geared motor generator, 12 or 24v input and many useful components, 37/6, carriage 3/6; cathode ray tube units, complete with 14 valves and tube, etc.; only 90/1, carriage 5/-; for other bargains see our latest list sent on receipt of 2/4d stamp.—Wilkinson, 204, Lower Addiscombe Rd., Croydon. (19576)

Partridge News

AVAILABLE STOCK

A comprehensive range of mains and audio components is now available from stock, and we can despatch small quantities of these per return. We would stress that before ordering you send for our list detailing these components. Our stock range now covers almost all normal requirements, and by availing yourself of this service you will save the inevitable delay in the production of a special component. We shall be pleased to send you our stock list upon receipt of your address.

★ ★ ★ ★

FIDELITY OUTPUT TRANSFORMERS

Our famous PPO range of high quality output transformers is now available from stock. These are now obtainable in a wide range of Valve/Speaker combinations (individual specifications not tapped). In effect we can now supply from stock an output transformer wound to conform to your exact requirements, unless you have a particularly unorthodox specification that we have not anticipated. A technical data sheet relating to this range is available free on request.

★ ★ ★ ★

THE NEW PARTRIDGE MANUAL

The completely revised post-war edition of this new Manual, now available, contains:—

Many useful circuits including New 15 watt high quality amplifier with 40 db of negative feedback over three stages. Also articles on Sound Reinforcing and Public Address, Acoustical Problems, Cross-over networks, etc. A useful appendix is included consisting of six selected design charts.

Price 5/- Post Free.

COUPON

Please send me post free a copy of the new Partridge Manual. I enclose P.O./Cheque value 5/-.

Name.....
Address.....

WW4

Telephone:  Abbey 2244

PARTRIDGE TRANSFORMERS LTD

76-8, PETTY FRANCE LONDON, S.W.1

W.W. Quality amplifier, built strictly to specification, with or without tone control stage, pre-amplifier, including hi-fi, P.E.C. types, mains and output transformers and chokes for this amplifier wound to W.W. specification; 12 valve, 20 watt, 4-channel electronic mixing; ac/dc amplifier and other a.n.c. dc types; 2/4 stamp for particulars, prices, etc.—to actual manufacturers, C. J. R. Electrical & Electronic Development, Ltd., Hubert St., Bgham, 6, Aston Cross 2440.

CHARLES AMPLIFIERS, Ltd., will be happy to demonstrate their famous model Concerto the ideal amplifier for second reproduction and their new model, the KI, swatts at 1/4 of 1% distortion; the KI is now available as a kit for home constructors (blue prints 2/6); also on demonstration all the leading makes of Pick-ups and loudspeakers; send stamp for fully illustrated catalogue with helpful advice on high quality reproduction.—Charles Amplifiers, Ltd., 1E, Palace Gate, Kensington, W.8, Western 3350. (19451)

CONNOISSEUR'S receiver. Combination 10-valve communication receiver and T.R.F. quality set. Fully converted R155 similar to super-het or T.R.F., 9-1,500 metres, with PX4 push-pull quality amplifier. Bass and treble boost (separate controls), gram input and other refinements, £35. Makes ideal radiogram. Write for full details or call for demonstration. We can modify your R155 similarly or to your requirements. R155 circuit at 500 valves, 2/- post free. Repairs, etc., to all communication and quality receivers.—R.T.S., Ltd., 8, Gladstone Rd., Wimbledon, S.W.19. Lib 3503

UNIVERSAL ELECTRONIC PRODUCTS, 36 Marylebone High St., London, W.1. Tel. No. Wel. 4058. Our U.E. amplifier, designed for the connoisseur who requires the best possible reproduction together with the highest standards of workmanship and materials. Write for descriptive leaflet. We invite you to hear this amplifier demonstrated in conjunction with the Wilkins & Wright pick-up and latest type speakers, including the new Whaifedale Corner Cabinet model. We specialize in high-fidelity sound reproduction for the home, clubs, concert halls, etc., and will undertake the design and construction of equipment to meet your own requirements.

GOODSELL, Ltd., 40, Gardner St., Brighton, 1, Sussex.—B.6735. A new amplifier identical to Williamson's but using P.X.25's in the output, giving 20 watts. Gardner mains transformer, two separate rectifiers, one at 500 volts and the other at 350 volts, with 50 mls 1 r your pre-amp and tuner, on two chassis, 27gns; the Williamson as per the W.W. using Partridge mains transformers and chokes, Osram valves at £21; valve controlled stabilised power pack for complete stability with high gain pre-amps, using 6L6, 6S7 and VR150-30, 26gns; pre-amp for use with any of above, using E.F.37 as triode and E.F.37 as pentode, giving two cuts and two boosts of treble and bass, and "straight". £4/6/6; with built-in Quality tuner for local stations only, complete with tuning eye, £9/9. 19669

RECEIVERS, AMPLIFIERS—SECOND-HAND H.R.O. and coil valve missing; offers over £10. (19428)

SX111 overhauled; nearest £20.—G6CY (19377)

AR88D 540kcs to 32mc receiver, as new; offers. Edinburgh, Box 5935. (19438)

R.C.A. A.R.88D comm. R.X., good condition; best offer over £50.—Box 6262. (19492)

HALICRAFTER S27, H.F. AM, FM receiver; new condition; £50.—Box 5683. (19350)

50 W amplifier, perfect, unused; 30gns.—11, Allandale Cres., Potters Bar, Middx. (19358)

SPECIAL offer: ultra small 4v mains set, fits waistcoat pocket; details free.—Box 5702. (19359)

YO 504, Eddystone comm. rec. type 504; what offers?—Sandfield St., Leyland, Lancs. (19360)

B.C.342 communications receiver, 1.5-18-mc/s; excellent cond; nearest offer £23.—Box 5079. (19361)

SX-28 super Skyriider for sale, perfect; what offers? Also 9 H.R.O. bandsped coil.—Box 6284. (19362)

R1155A receiver, modified, KT63 output stage, power pack, loudspeaker; £18.—Bridgland, 73, Belgrave Rd., S.W.1. (19325)

AR88D, perfect condition. "S" meter, tuning overhauled by me; some spares, valves, £50 for quick sale.—Box 5694. (19360)

R.C.A. AR88 0.54-32mc, 6 wavebands, bandspread, perfect condition, service data, £75 or good offer.—Box 5747. (19395)

CROSSOR television & wireless set (completely overhauled by me); screen 11 1/2in X 9 in; £120; inspect by appt.—Box 6270. (19313)

50-watt amplifier, rack mounting, nice oo, scarcely used; including output transformer and P.E. cell, £25.—Box 5701. (19378)

NATIONAL L1-10 receiver and power pack, coils, good working order but rather shabby; £12.—Lavin, Old House, Sonning, Reading. (19377)

11 55 com. receivers, 5-wave band, £13/10.—Pipet, Buskett's Way, Ashurst, Southampton, 19422

HAYNES radiogram, P.25 output, super tone; recently overhauled, mahogany cabinet; reasonable offer.—Tel. Palmers Green 3283. (19378)

HAMMARLUND Comet 3, 3 I.F., B.F.O., spare valves, excellent condition; £40.—Seeley, 200, Ryefield Ave., Hillingdon, Middx. (19378)

EDISTON 400X comm. rec., 7 valves, crystal, meter, as new but less coils; offers over £18.—21, Langton St., S.W.10, Fla. 6928. (19378)

NATIONAL H.R.O. power pack, nine coils, all in rack mounting, as brand new and perfect; £60; buyer collects.—Details from Box 5697. (19378)

High Quality TRANSFORMERS and CHOKES

Made specially for your requirements. All coils layer wound and insulated between layers.

Our modern factory is fully equipped with vacuum and pressure impregnators and all the latest testing equipment.

POWER OUTPUTS
up to 4 K.V.A.

AUDIO RATINGS
3-200 watts

AUSTIN MILLS LTD.
LOWER CARRS,
STOCKPORT

Established 20 years. Phone: STO 3791

YOU can become a first-class RADIO ENGINEER

We are specialists in Home-Study Tuition in Radio, Television and Mathematics. Post coupon now for free booklet and learn how you can qualify for well-paid employment or profitable spare-time work.

T. & C. RADIO COLLEGE
North Road, Parkstone, Dorset

(Post in unsealed envelope, 1d. stamp)

Please send me free details of your Home-Study Mathematics and Radio courses.

NAME

ADDRESS

W.W.70.

6-VOLT car radio, 9 valves, 5 wavebands, press-bar tuning, superb tone, excellent condition; £25.—Bolton, 28, Union St., Newton Abbot, Tel. 1070. 19316

COMMUNICATIONS receiver B.C.348, built-in power pack (ac mains), 9 valves, 6 bands, as new, perfect; £35.—Abbott, 60, Udimer Rd, Rye, Sussex. 19349

AMPLI gram (8 watts A.C.), with speaker; 2 R. & A. horn speakers, D.104 mike and stand; £40 lot, or offers.—11, Daltongate, Ulverston, Lancs. 19365

R1155 receiver, R.T.S. mod., 11 valves, cost £35; nearest to £20 accepted; in perfect condition owner leaving country.—92, Vaughan Rd, Wallasey, Ches. 19319

B.C.342 receiver, 110volts a.c., with valves, shockproof base, and makers' 100-page instruction manual; £19/10.—Harris, Strouds, Pangbourne, Berks. 19488

B using regenerative 1853 television pentode; £5.—A. E. Cawke, 7, Victory Arcade, The Broadway, Southall, Middx. 19311

WIRELESS WORLD 2-R.F. quality tuner amplifier, new, £5/10 less valves, which are easily obtained; 6 wavebands, HF, FC, 21F. 19318

PHILIPS 1947 table model 170a 5-valve magic eye superhet, absolutely perfect every respect; no reasonable offer refused.—Beckenham 5989 after 7 p.m., or Box 5680. 19341

Q-VALVE semi-communications receiver, job constructed, 6 wavebands, HF, FC, 21F, etc., hardly used; £30, quick sale; s.a.e. to: A. Halford, Woodside, Eastnor, Herefordshire. 19322

W.W.Q.A. with 1939 2 R.F. pre-tuned receiver, full tone control, Magnavox duode motor, crystal P.U., oak gram cabinet, must sell, nearest £40; would separate; see S.E. London.—Box 5750. 19402

R.A.F. type 1124 receivers with 6 valves, 3 I.F. stages, ideal to convert for television base, sound assured, £10 worth of components, bargain, 35/-, carriage paid; send s.a.e. for surplus lists.—J. Rae, 39, Penn Rd., Wolverhampton. 19632

QUALITY enthusiasts offers specially built 15-watt push-pull amplifier (FX255), in 1mhf cabinet, high fidelity local station tuner, floor cabinet record player with moving coil pick-up, Vitavox Bitone speaker, complete; £120.—Box 5664. 19322

BC348R, modified 200-240v ac, 9v comm. receiver, 2 r.f., 3 i.f., b.i.o., Xtal gate, a.v.c., m.v.c., 200-500 kcs and 1.5-18 mcs, 6 bands, as new, with handbook; exchange s.h. radiogram or sell £27/10, or offer.—Fry, 10, Overmead, Sidcup, Kent. 19342

ANDA size Romac portable personal receiver for sale, £20 or offers, 4 weeks' use since purchase, brand new, perfect order, sole reason for sale mains set wanted, as now in house with mains wired.—M. D. Hynard, 2, Elm St., Buckingham. 19655

PUBLIC address.—Two complete p.a. units by Parmeko, each comprising amplifier with power pack, folded horn speaker, moving coil microphone, 12 volt battery, cables, plugs, etc., also box spares, including 2 sets spare valves, condensers, instruction book, etc., new but slightly store soiled; complete outfit £44, carriage.—Ward, 85, Malt Mill Lane, Blackheath, B'ham. 19357

COMMUNICATION receiver by Telefunken, acknowledged by experts to be far superior to anything on English or American markets; precision made and tropical proofed, range 1-30 mcs, calibrated to three decimal points, bandspread and all scales protected on ground glass screen, 13 tubes, all identical and interchangeable, set of spares included, all voltage mains 110-250v a.c. and 12v battery, crystal control and B.F.O.; price £70 or near offer.—Write Bown, 126, New Church Rd., Hove, Sussex. 19306

P equipment, demonstration models practically new and unused, slightly reduced; Tannoy d.c./a.c. High Gain 25watt amplifier, £35; Tannoy a.c. 60watt amplifier, High Gain, £55; Trix a.c. 30watt amplifier, in polished case, fitted with gram, motor and pick-up, £50; Rothenel a.c. 60watt amplifier, multi input, £35; Meico a.c. 30watt push-pull 807s, £30; Acoustical 90-120watt amplifier with limiter circuit, £52/10; l.s. matching unit and mic. mixers available; Pam d.c./a.c. amplifier in portable case, incorporating loudspeakers, £30/9; a.c. record players, loudspeakers, converter units, microphones and stands; enquiries invited.

LARG'S, Public Address Stockists, Whitehall St., Dundee. 19499

FOR sale.—R.C.A. model 348 10-valve communications receiver, frequency range 200-500 kcs and 15-18 meg, in six ranges; bandspread tuning, xtal filter. BFO AVC-MVC, modifications from standard include mains operation, H.T. milliammeter, radio and pick-up on/off lights, pick-up or mike amplifier, the external speaker is a Marconi 10in x 5in oval model in a black cradle cabinet to match the set, and is fitted with rubber feet; spares and extras include complete set of spare valves, plus some duplicates; one Acos xtal pick-up, one travelling case for all the above, apart from the speaker; this is a suitcase type with buffalo hide on a plywood base and fitted with straps to keep dials, etc., from being damaged; price, complete with instruction booklet, 35s.—Apply to W. L. G. Nicoll, c/o Mrs. Hemsworth, Oxford and Cambridge Mansions, Marylebone Rd., London, N.W.1. 19365

U.S.A. 2-VOLT VIBRATOR PACKS

(As used for the famous Canadian "Walkie-Talkie.")

Now made available at the reduced price of £3/7/6, complete with 2 v. 20a. accumulators in carrying case (carr. & pkg. 7/6).

Specification Input 2 v. D.C. Output 90 v. or 180 v. 35 m/a., 1.5 v. L.T.

The Vibrator unit is detachable from the accumulator container unit. Size 8in. x 3 3/4in. x 4 1/2in. Spares: 2 v. 7-pin synchronous vibrators 9/6; 10 amp. fuses, 6d. Accumulator units containing 2 v. cells, 15/-. Vibrator pack units only 52/6. Carrying cases, 5/-. (Add Carr. & pkg.)

R10? COMMUNICATIONS RECEIVERS. This brand new type 'T' (signifying special test job), 8-valve receiver for only £6/15/-. (Carr. & pkg. 10/-) Frequency coverage 1.8—8.5 mcs (2 bands). Valve line-up 5 AR12 and 3 AR8. Power supply (6v. vibrator pack), built in, 3 1/2in. Speaker incorporated, and also supplied with set of spare valves. B.F.O., A.V.C., etc. A few only left! Circuits provided.

R1224A COMMUNICATIONS RECEIVERS. A 5-valve battery superhet complete with 2 VP23, FC2A, HL2 and KT2. Coverage 30-300 metres, and supplied in wooden transit case. Circuits provided. Batteries: HT 120 v., G.B. 9 v., L.T. 2 v. New and unused for only £4/19/6. (Carr. & pkg. 7/6).

BC21 FREQUENCY METERS. Frequency coverage 125 kcs—20 mcs. Crystal controlled oscillator, heterodyne oscillator, A.F. amplifier. Complete with valves and crystal. Only £13/19/6.

POST ORDERS to 3, Robert Street, Hampstead Road, London, N.W.1.

M.O.S. MAIL ORDER SUPPLY CO.

Dept. W.W. 24, New Rd., London, E.1
Stepney Green 2760-39C6.

THE BRITISH NATIONAL RADIO SCHOOL

ESTD. 1940

A privately owned personally conducted coaching service by post

SERVICE SATISFACTION

SINCERITY

PLUS A GUARANTEE

that really means Something

ORIGINATORS of the B.N.R.S.

FOUR YEAR PLAN

Covers full syllabus of A.M.I.E.E., A.M. Brit. I.R.E., and C. & G.

Radio and Telecommunications Examinations at a cost equivalent to **4 CIGARETTES PER DAY**

Free Booklet from:
Studies Director, B.N.R.S.,
66, ADDISCOMBE Rd., GROYDON
Phone: Addiscombe 3341

ALEC DAVIS Supplies LTD.

18, Tottenham Court Road,
LONDON, W.1.

A few more selections from our wide range of ex-Govt. surplus equipment!

- CONDENSERS:**
Bakelite cased high voltage condensers (postage 3d. extra)
2 mfd. 200 v. d.c. wkg., size 1 1/4 in. diam. x 3 1/4 in. 1/-
1 mfd. 2,500 v. d.c. wkg., size 1 1/4 in. diam. x 3 1/4 in. 8d.
1 mfd. 1,500 v. d.c. wkg., size 1 in. diam. x 2 1/2 in. 6d.
1 mfd. 600 v. d.c. wkg., size 1 in. diam. 2 1/2 in. 6d.
0.3 mfd. 2,500 v. d.c. wkg., size 1 in. diam. x 2 1/2 in. 6d.
0.1 mfd. 5,000 v. d.c. wkg., size 1 in. diam. x 2 1/2 in. 6d.
0.1 mfd. 3,000 v. d.c. wkg., size 1 in. diam. x 2 1/2 in. 6d.

MISCELLANEOUS:
Exide new and unused accumulators in moulded case. Size 2 1/2 in. square by 6 1/2 in. high—2 volt type, 7/6 (postage 1/-).
Inert cells 15-volt type. Size 9 in. x 1 in. x 3 in. 1.6 each (postage 6d.).

Set of four 15-volt cells in sealed can. 5/- (postage 1/-).
Moving coil headphones and microphones, new and unused, boxed, 12/6 per set (postage 8d.).
Paxoline tubes, 2 1/2 in. diam., 6 1/2 in. long. 4/6 (postage 9d.).

R.F. 5 amp thermo couple meters, 2 in. type, new and boxed. 7/6 (postage 6d.).
Ex-Admiralty slow motion drives, new and boxed. 5/- (postage 6d.).
Dual range pocket voltmeter, 2 in. diam., 0/15 volts: 0/250 volts. Ideal for battery users. New and boxed. 18/9 (postage 6d.).

Carbon potentiometers 2K, 3K, 10K, 25K, 50K, 100K, 250K, 500K, and 1 meg. All at 2/- each.
Wire-wound potentiometers—all normal values: 4-watt type, 3/- each; 2 1/2-watt type, 2/6 each.
5 mA bridge type instrument rectifier, 4/- each.
Ceramic mounted 2-gang double-spaced variable condenser, 34+34 pF. Size, 1 1/4 in. x 2 in. x 4 1/4 in. depth, 7/6.

Surplus Equipment at Surplus Prices. Stockists of Valves, Batteries, Components and Test Equipment.
Business Hours: 9 a.m.—5.30 p.m. Mon./Fri.
9 a.m.—1 p.m. Sat.
Telephone: MUSeum 4539.

OPPORTUNITIES IN RADIO



Get this FREE Book!
"ENGINEERING OPPORTUNITIES" reveals how you can become technically-qualified at home for a highly-paid key-appointment in the vast Radio and Television Industry. In 108 pages of intensely interesting matter, it includes full details of our up-to-the-minute home study courses in all branches of TELEVISION and RADIO, A.M. Brit. I.R.E., A.M.I.E.E., City & Guilds, Special Television, Servicing, Sound Film Projection, Short Wave, High Frequency, and General Wireless Courses.

We Definitely Guarantee
"NO PASS—NO FEE"

If you're earning less than £10 a week, this enlightening book is for you. Write for your copy today. It will be sent FREE and without obligation.

BRITISH INSTITUTE OF
ENGINEERING TECHNOLOGY
388b, Shakespeare House,
17/19, Stratford Place, London, W.1.

CHARLES BRITAIN (RADIO) Ltd.

R.F. UNITS, types 24 and 25, contains 3, S.P. 61, 5-way, 3-bank, ceramic switch, etc., easily adapted for use as S.W. converter, 16/6 post free. R.F. unit type 26: this is a more up-to-date version, with Vernier slow-motion drive, complete with 2 RL7, 1 RL16 valves, first-class condition; price 27/6, post free.

INDICATOR unit with 6in tube, complete with 6in non-persistent cathode ray tube, 7 valves follows: 4 EF50, 3 EB34, contains many useful components, including 12 pot-meters; tube is suitable for television or scope; price £2/19/6; this item to callers only.

TEST Set 74, consists of a special purpose scope, with 6in CRT tube, with built-in receiver of sender (I.F.F.), and will work directly off a.c. mains. 230v 50 cps; this unit is in a case size 18in x 12in x 9in, with carrying strap; this unit can be easily converted to a scope; price £5/19/6, plus 15/- carr. and packing.

CHARLES BRITAIN (RADIO) Ltd., Radio House, 2, Wilson St., E.C.2, Tel. 2966.
PULLIN series 100 test meter, as new; £8 or near.—Box 5751. [9403]

B.P.L. all-wave mains oscillator, brand new sacrifice at £17.—Box 5749. [9399]
HYDROMETERS, unbreak glass new ex-RAF, 3/6 or 4/6, below.
METER bargains! All brand new, boxed, m/coil, electrostatic voltmeters, Elec. Inst. Co., 5,000 volts, 3 1/2 in flush mtk, 30/-; ammeters, M.I.P., 0-20amps, 2 1/2 in flush, 10/-; milliammeters, Sangamo Weston, 0-350 m.a., thermo-couple I.F., 2 in. proj., 5/6; Ferranti ditto, 0-200 m.a., 7/6.—Below.

VISUAL indicators, type 3, contain 2 comp. Weston 300 micro amp movements in bakelite case, with 2 1/2 in dial, 2 scales, 2 lamps and s.p.c. holders, brand new, boxed, 7/6.—Below.
W.F.E. Meggers, 250 volt, brand new, complete leather case, £8 (list £12); see also "Components" advt.—Auto Collections, Ltd., 126, St. Albans Ave., London, W.4. [9661]

ULTRA osc., 3in tube, versatile instrument, a most new; £25 or offer.—Park 401.
UNIVERSAL A.V.O. tester, a.c./d.c., new, £6.—U18, Wallingford Rd., Davyholme, Lancs.

A.V.O. valve tester, £11; Avo bridge, £9; Avo osc., £10; electronic timer, £5.—Gra. 3126.
TEST gear in kit form.—Illustrated lists and details from L. A. MacLachlan & Co., 16, Thistle St., Stirling. [9505]

B.P.L. wobulator, perfect, Taylor model 40 valve tester, 3in oscilloscope; offers.—Bedwell, 10, Winchcombe St., Cheltenham. [9375]

A.V.O. 40 meter, £11; Avo valve tester, recent model, £14/10; Taylor ditto, 1 1/2 in. tube, £18.—Watts's, Peak Buildings, Buxton, [9452]

BC-221 signal generator (latest type AJ with modulated output), with spare valves and 60-page instruction manual, all brand new in makers' case; £16/10.—Harris, Strouds [9454]bourne, Berks.

FREQUENCY meter BC.221.—Crystal control 126 kc/s to 20 mc/s accuracy better than 0.01%; new £45; 45-page manuals giving circuit and full details 7/6.—V.E.S., 46, Windmill Hill, Ruislip Manor, Middlesex.

SURPLUS to requirements, B.L.P. all wave signal generator in new condition, recently overhauled by makers, complete with leads and instruction book; £16.—Goulding & Williams, 10, Earle St., Wrexham. [9406]

BRIDGE megger, Avometers, Cap. Res. bridge valve tester, wavemeter, 12 volt and a.c. 20 watt amplifiers, 15in spk., power packs, sun lamp, all in excel. condition; best offer secures.—Bolton, 28, Union St., Newton Abbot, Devon.

MICRO ammeters, model 505 d.c. Turner electrical instruments, f.s.d. 100-0-100, moving coil, zero set screw, dead beat, 2 1/2 in. dial, 3/4 in. diameter, moulded bakelite case, new and in original cartons, 1st grade, 30/-.—Below.

AMMETERS, range 0-100, moving coil, with leads and shunt, by Victoria Instrument Co., 3in. flush fitting, bakelite case, zero set screw, dead beat, new, in original cartons, 1st grade; 25/-.—Below.

AMMETERS, 50-0-50, moving coil, by Ferranti or Weston, 2in square dial, flush fitting, bakelite case, zero set screw, dead beat, new, in original cartons, first grade, 21/-.—Below.

VOLTMETERS, range 0-120, moving coil, by Victoria Instrument Co., 3 1/2 in. flush-fitting bakelite case, zero set screw, dead beat, new, in original cartons, 1st grade; 22/6.—Below.

TEDDINGTON ENGINEERING Co., Ltd., High St., Teddington, Kin. 1193-4. [9223]

TEST set 73, modification details now ready. Instruction booklet and four blueprints covering conversion of test set 73 to first-class scope. Post free £1.—L. P. Dismore, Oldchurch Laboratories, 52c, Old Church Rd., Chingford, E.4. [9401]

PORTALIGN mains signal generators, audio mod. calibrated to 30 mc/s, 28/5, plus 2/6 packing and registration; 0005 air diel. var cond., 3/3; mains transf., 230v. pri., secs., 240v. 30ma, 6.3v. 45a, 17/-; 30ma. metal rect., 6/-; 5in P.M. speaker, 15/-; postage extra.—Metro Radio, 67, Sussex Rd., Harrow. [9595]

1000 kc oscillator units containing standard 1.000kc but need only valve inserting, connecting to filament and H.T. supply for perfect 1.000kc oscillator, 17/6 each; special terms to trade. Sectional vertical aerials—6 sections, 18ft long, positive screwed connection between sections, 12/6 each; cycloidal reduction drives, few only, new 1/9 each. H. R. Welsby, 1, Cobnar Drive, Sheffield. [9400]



Fundamentals of Radar

By Stephen A. Knight, F.R.S.A. This useful book surveys the principles underlying radar, and is of special interest to radar operators and students, as well as those engaged in the industry. Illustrated. 10/- net.

Radio Receiver Servicing and Maintenance

By E. J. G. Lewis. Gives the radio dealer and service engineer up-to-date and reliable assistance in the technical details of their work. A handy fault-finding summary is a feature of the book. 8/6 net.
"Practical, replete with facts, and well arranged."—"Wireless World."

Cathode Ray Oscillographs

By J. H. Reyner, B.Sc. (Hons.), A.C.G.I., D.I.C., etc. A comprehensive account of the practical applications of cathode ray tubes and the theory underlying them. "Electrical Times" says: "Anyone desiring an understanding of the cathode ray oscillograph cannot do better than purchase this book." 8/6 net.

Pitman

Parker Street, Kingsway, London, W.C.2

Specialists in

HIGH POWER - HIGH QUALITY

PUBLIC ADDRESS SYSTEMS

★
AMPLIFIERS

from 150 W to 1kW

W. Bryan Savage Ltd
WESTMORELAND ROAD, LONDON, N.W.9

Telephone: Colindale 7131

A.C. eliminators, 120v d.c. output, 30 ma. 30/-; 0-1 milliameters, 2in. wire coil, F.S.D. 5/-; Morse keys, 1/6; Solon medium soldering irons, 220-230v, 14/6; Dipole aeriels, 2/-, bench voltmeters, 0-20 d.c., 9/-; c.w.o. plus postage.—

Chaplin, 39, High St., Saitley, B'ham. 8.
TAYLOR, 47A valve tester, 200-250 volts, 16 valve sockets, 1.1-1.17 filament volts and 1,000 ohms per volt, a.c./d.c. set analyzer, £20; a.c. operated "Avo" all-wave scilator, 6 fundamental and 1 harmonic scales, switch for L.F., int., ext. and R.F., 2 dummy aeriels, £15; both above lots nearly new.—Whereby, 22, Fifth Ave., Ooze Wood, Royton, Lancs.

WRIGHT & WEARIE condenser, analyzer and resistance tester, mains, direct readings. £20; Avo valve tester with 2 panels, £20; Avo laptop, £1; universal Avometer in leather carrying case, £18; Dixonometer with 10 shunts £6; Baker 12in speaker, 32volt field, £5; all in first-class condition, but will consider offers; 50-volt battery, stand, 10ft long, pitch pine, perfect condition, £6.—Nance, Parade, St. Mary's, Scilly Isles. [19561]

FOR sale, R.C.A. signal generator, frequency range 125-20,000kc/s in two ranges, provides xtal output on 1,000kc/s and harmonics, 500 ma. c.w. output, accuracy 0.002%, spares include spare 1,000kc xtal and two sets of spare valves, operates off h.t. battery 135v and 1.1. 6v (4 twin-cell cycle batteries in series parallel); price complete with above 12½gns.—Apply to W. L. G. Nicoll, c/o Mrs. Hemsworth, Oxford and Cambridge Mansions, Marylebone Road, London, W.1. [19386]

COMPONENTS—SECOND-HAND, SURPLUS SOUTHERN RADIO'S wireless bargains.

RADIO publications: Radio Valve Manual, British and American alternatives and equivalents, 3/6, post 3d; all publications previously advertised still available, send 25d for full list. A.C. motors, 200/250 vots, 1½ (one-eighth) hp, ½ amp (one-half amp, suitable for light work, sewing machines, etc; brand new, 55/-, packing and carriage, 5/-; input transformers, ratio 1:50 mu metal, 4/6, post 1/-; ratio 1:7 mu metal, 4/6, post 1/-; small folding di-pole aeriels (V.H.F.), 4/6; Leathers adjustable hole cutters, for use on wood metal or plastic, 5/-, post 6d; midget twin gang condensers, 75 pf, 5/-, post 6d; midget single gang condensers, 75 pf, 2/6, post 6d; throat microphones, brand new, with 3ft lead and plug, 4/6, post 6d; throat microphone inserts (2 in box), 1/6 per box; special offer recording disc, double sided, five and three-eighth in, 1/3; permanent crystal detectors, 2/6, post 4d; M.C.R.I. batteries, 7½v l.t., 90 volts h.t., 6/6, post 9d; Westectors, W.X.6 and W.112, 1/- ea, post 2d; brand new oil filled condensers, 1mfid, 7-500 volts d.c., 7/6, post 1/6; 5mfid, 7,000v, 1/6, post 1/-; ex-Army headsets, brand new, with carbon mikes and moving-coil phones, 12/6; telephone line units, rectifier, relay, two jack sockets and indicator lamp in wooden box, brand new, 6/-.

SOUTHERN RADIO SUPPLY, Ltd., 46, Lisle St., London, W.C.2, Gerrard 6655. [19577]

G. W. SMITH & Co. (RADIO), Ltd., offers the following:—
Ex-R.A.F. type 39 aerial coupling units, with 0-3 and 0-6 thermo meters, 17/6 each; I.F.F. receivers with valves, 29/6; W.119, crystal wavemeters, boxed with spare set of valves, £7; type 30 U.H.F. units with valves boxed new, 27/6 each; 150-watt constant voltage transformers, new, £4/10; Weston BC 454 receivers, 3-6m/cs, with valves and rotary pack, 59/6; interphone amplifiers, AM26/AIC, with valves and pack, 49/6 each; R1124 receivers, with valves, suitable for English and French, 12/6 each; automatic pilot amplifiers, boxed with valves, 32/6 each; amplifiers less valves, 12/6 each; 0-20 a.c. voltmeters, 2½in flush, new, 10/-; 0-20 a.c. ammeters, flush, 2½in, 10/-; 24-volt rotary transformers, 250v and 6.5v, 10/-; R3513 receivers, new and boxed, 45m/s sp, on with circuit for television adaption, £4 12 6.
G. W. SMITH & Co. (RADIO), Ltd., 3, Lisle St., London, W.C.2, Gerrard 8204. [19620]

B. & H. RADIO for components for the service engineer, aerial instruments, from stock, trade only, stamp for lists.—Huntley St., Darlington. [19374]

AMERICAN transformers, 230v pri., sec. 300-0-300 80ma, 6.3v 5a, 5v 2a shrouded, 20/-; ditto 110-230v pri., 25/-; Dublier paper condensers, 6mfid 1,000v, wk, 10/-; Box 5667, [19322] "YOU'll probably get it at Smith's, Edgware Rd.!" Everything for the constructor, from a 1/10watt resistor to a radiogram cabinet; lowest prices, biggest variety.—Near Metropolitan Music Hall, Pad. 5891. [19005]

TELEVISION aerial equipment, 5 types fully water-proofed aeriels available, poles, lashings, all types of feeder in stock; send for brochures; aeriels installed.—Wolsey Television, Ltd., 87, Brixton Hill, S.W.2, Tulse Hill 1240.

NEWSON'S for new components.—Rola 10in. less trans, 30/-; Rola 8in. less trans, 24/-; Goodmans 12in. Axion, £8/8; condenser; T.C.C. B.I., Hunt's, etc., 2mfid 3/-, 4mfid 3/9, 8mfid 4/-; 16mfid 4/9, 16/24mfid 6/9, 16/16mfid 7/9, all 450volt working; 16/24mfid 350v w. 8/6, 2mfid 350v w. 2/3; 25mfid 25v w. 2/-, 8mfid 150v w. 1/11; large stocks; s.a. 10/-; c.w.o. over 11, postage extra.—Newson's Radio, 42, London Rd., Romford, Essex. [19312]

ARMSTRONG

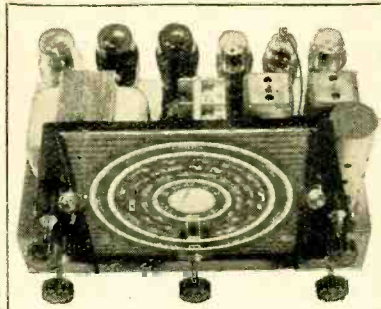

**Model RF103
10 VALVE ALL-WAVE SUPERHET
RADIOGRAM CHASSIS.**

SPECIAL FEATURES

- ★ 10 VALVE CIRCUIT.
- ★ R.F. PRE-AMPLIFIER.
- ★ WAVE BAND EXPANSION.
- ★ LARGE GLASS SCALE.
- ★ 3 STAGES A.V.C.
- ★ TREBLE LIFT CONTROL.
(Operates on both radio and gramophone.)
- ★ PLUS 6 db. BASS LIFT ON GRAMOPHONE.
(To restore bass cut on some records.)
- ★ 10 WATT PUSH-PULL OUTPUT.

To export buyers we can confidently recommend RF103 to any firm abroad who contemplates making a high-grade Radiogram or Console radio receiver.

The lively short-wave performance coupled with the excellent quality reproduction ensure an outstanding performance.

We will gladly make any alterations to the specification to meet individual requirements.

To home buyers demonstration model now available to interested callers to hear, and technical specification now available on request.

It is hoped that a number (very limited unfortunately) will be available for early delivery.

The above model is for A.C. Mains. We also have a similar model Type UNI 103 for DC/AC Mains.



ARMSTRONG WIRELESS & TELEVISION CO. LTD.
WALTERS ROAD, HOLLOWAY, LONDON, N.
Phone: NoRth 3213

230v input transformers, output 885-0-885, 37ma 6v, 3arms 4v, 2amps, 19/6; 6mfid 150v condensers, 9d; 10mfid 1,000v, 7/6; panel with 16 one-way toggle switches, 3/9; all carriage paid.—Passingham, 95, North St., Keighley. [19277]

H.T. transformers, input 230volts, output 5,000 volts at 20ma, separate bobbins, standard insulators, 35/- each, post free; 2in. thermo-couple moving coil, 0-350; milliammeters, a bargain at 5/6 each, post free.—J. McMillan, 5, Oakfield Rd., Bristol, 8. [19357]

RELAYS, standard Post Office 3000 type, new, 500 ohm, DFCO 2/3 ea. TPCO 2/6 ea; Dewar keys, new DFCO 2 post locking, 2/6 ea.; DFCO x DFCO, 3 post, non-locking, 3/6 ea.; all items post paid.—Ward, 85, Malt Mill Lane, Blackheath, B'ham. [19340]

QUANTITY s.w. components, including tuning condensers, flexible couplings, r.f. chokes, etc., etc., mostly new, suitable for amateur or servicing work; approximate value new £35; price £10.—A. E. Cawkell, 7, Victory Arcade, The Broadway, Southall, Middx. [19310]

THREE-STAGE resistance capacity miniature T amplifiers with three tested 1T4 midget valves, 20/- each, post free; in aluminium case, 22/-; spare 1T4 valves, guaranteed, 6/- each; holders 6d each.—Littler, 24, Stanley Rd., Whalley Range, Manchester, 16.

15,000 Selenium rectifiers by S.T.C. and Westinghouse, 5 types, 30 ma. to 220 ma., 50 to 360 volts, all new tested stock, substantially discounted for quantities.—Apply for full technical data and prices, Partridge, Wilson & Co., Ltd. Davenset Electrical Works, Leicester.

TUNING hearts, 1. and m., £3/15; l. m. and s., £5; permeability tuned i.t., 15/-; p. and s., 8-10 watt p.p. amplifiers, chassis form, £8/8; modern case, £12; 20watt p.p. in case, £18; m.c. mic., £4/4; stamp for full details.—Midland Radio Coil Products, 19, Newcomen Rd., Weymouth, Dorset. [19324]

FIRTH RADIOCRAFT, Ltd., the Leicester specialists, offer from their comprehensive stocks: Rotary converters, input 24v d.c., output 230v a.c. 50 cycles, 100-200 watts, in steel cases with carrying handle, ideal for mobile amplifiers, etc.; further supplies of these are now available at £3/15.

BATTERY communications receiver, 5v s'het, i.f. stage, 1 to 9 mc. in 3 hands, complete, tested and guaranteed OK, with 5 Mazda Octal valves, £4/19/6.

BENDIX radio compass receivers, model, MN26C, 3 bands covering 150-325, 325-695, 695-1500 kc/s, 2 r.f. stages, with 12 new metal valves (5-6SK7; 2-6J5; 2-6N7; 1-6BB; 1-6F6; 1-6L7); rotary converter for 24/28v operation; complete with full instructions for converting to a.c. operation, £10. R.C.A. filament transformers, 210/230/250/40/60 cycles, 2x5v 10a, 5v 20a, 2.6v 10a, all centre tapped, unrepeatable at £3; standard U channel steel racks (for 19in panels), 4ft 10in high with base plates, £2.

BARGAIN parcels: over 50 useful ex-Gov. components, our selection, £1; Systonex, 72 vds. asstd., 5/-; new resistors and condensers, 25 asstd., 5/6; 50 asst., 10/6; 100 asst., £1. Satisfaction guaranteed on money refunded without question. Latest lists free on request. Trade supplied.

FIRTH RADIOCRAFT, Ltd., 69-71, Church Gate, Leicester, Tel. 58927. [19572]

SUPER-QUALITY mains transformers, 230v primaries, 350-0-350v, 300ma, 2x6.3v, 5v, 20-0-20v, 37/6, carriage 5/-; 2x350-0-350v, 200ma, 3x6.3v, 2x5v, 55/-, carriage 5/-; 1.f. chokes, 20-henry, 300ma, 20/-; other interesting items, s.a.e. list.—Cross, 19, Riverside Rd., Weshire, Kirby, Cheshire. [19520]

W.W. television coil formers set and slugs, 7/6 for 9; 1-1 trans, for frame T.B., 3/6; 100 ma 15h chokes, cast case, 8/-; speakers, 10in P.M., 37/6; 8in P.M., 19/6; 5in P.M., 15/-; 5in 750a field+O.P. trans., 25/-; valves 6A7, new, 14/-; postage extra under £1.—Taylor, 24, Enmore Rd., Putney, S.W.15. [19392]

COPPER wires, enamelled, tinned, Litz, cotton, silk covered, all gauges; B.A. screws, nuts, washers, soldering tags, eyelets; ebonite and laminated bakelite panels, tubes, coil formers; Tunol rod, headphones, flexes, etc.; list of trade grade supplies.—Radio Supplies, 33, Bourne Gardens, London, E.4.

MANUFACTURERS; huge stocks all components, S.M. M/M, P.T. and block condensers, close tolerance resistors and all types resistances, potentiometer, laminations, valve holders, glass cartridge fuses, 1½in; suppliers to leading manufacturers; all goods guaranteed.—L. E. Simmonds, 10, Valencia Rd., Stanmore, Mx, Grimsdyke 608.

ENTIRE stock and plant of radio, television and electrical engineers' business, must be sold, space urgently needed for conversion to manufacturing; 700 valves, radio receiver, cathode ray tubes, meters, etc., etc.; send for complete lists of items; to be sold in one lot at £1,400 (all new stock).—E. A. Porritt, 13, Wadelaide Rd., Forest Hill, S.E.25. For. 1292. [19423]

KIT'S of radio receivers from £2 to £5, 5-valve new materials, table models, semi-midget; our latest kit.—Wylwyn Star 1948 has connections for gramophone pick-up, extensions to loudspeaker, A.V.C., 6 hours average time for constructing; full details, diagrams with parts list, c.w.o. or c.o.w.o. to: Rame House, 81, Plungington Rd., Preston, Tel. 3548, Estd. 1936. [16788]

RECORD



'MINOR' INSULATION TEST SET

Compact and inexpensive without sacrificing accuracy and reliability. Weighs only 3lbs. Height allows for full swing of generator handle. Ranges up to 20 megohms 500 volts.



CONTINUITY TESTER

This latest addition to the Record Ohmmeter range is enclosed in a moulded bakelite case of pleasing appearance. Equipped with self-contained dry battery. Specially designed test spikes and leads can be supplied, also a "test and carry" case in which the instrument may be used without removal. Ranges—0/3—0/30 ohms. 0/30—0/300 ohms. 0/500—0/50,000 ohms. 0/1000—0/200,000 ohms.

THE RECORD ELECTRICAL CO., LTD.
Broadheath, Altrincham, Cheshire.
Tel. Altrincham 3221/2. Grams: "Infusion," Altrincham.
LONDON: 28, Victoria St., S.W.1. Phone: Abbey 5148

HENRY'S

ELECTROSTATIC VOLTMETER. 0-5000 volts 3 1/2 in. scale. By leading manufacturer, new and unused, 65/- only.

RECTIFIED OUTPUT METER. 4 in. square face F.S.D. 1 ma linear graduation, 0-10, ex-Govt., by Taylor Inst. In a strong wooden carrying case, 55/-.

B.C. 221 CRYSTAL CONTROLLED FREQUENCY METER. A further purchase now enables us to offer this well-known American instrument at £15 only. Apart from crystal, contains 2 6S7, 6K8, plus complete set of spare valves. Calibrated charts and instruction booklet supplied. Coverage 125-20,000 kc/s. Battery operation 130 v. H.T., 6 v. L.T. Ample space available for easily constructed mains pack. Brand new, by Philco, Bendix, etc.

In addition to the above ex-Govt. bargains, we carry the most comprehensive up-to-date stocks of components for the amateur and serviceman alike.

DRY BATTERY VALVES. We can definitely supply from stock: DK32(A7) at 13/11, DL35(OH) at 12/-, DF34(18) at 12/-, and DAC32(18) at 10/-. Also for personal receivers, 1B5 at 15/10, 384 at 14/-, 1T4 at 14/-, and 1B5 at 15/10. All above prices inclusive of Purchase Tax.

We have in addition many other "Difficult" types. All enquiries for same will be answered per return.

SPECIAL DELIVERY. Electric Gramophone Motors. Collaro, a.c. 50 c/wds, 200/250 volts, 10m. turnable, complete with magnetic pick-up, automatic stop-start, speed regulator, £9, including P.T. Postage and packing, 5/- extra. Cash with order only please.

Send stamp for Current Component List.

CASH WITH ORDER, OR C.O.D. (OVER 1)

5, HARROW ROAD, W.2

PADDINGTON 1008/9

MANUFACTURERS clearance, a.c./d.c. 3v TRF chassis M&L fitted all main parts, including rectifier and speaker, £3/10; 4v superhet, £4/10; TRF chassis as above, wired with resistors and condensers, £4; cabinets from £1; valves from 5/-; line-cord 5a 3-way, 1/3 yd. T.P. transformers 468k/acs. 40/-; S.M.L. dials, 4/- doz. 30/- gross.—Cook, Old Barn Rd., Christchurch, Hants. [9580]

SHORT wave coils, chokes and condensers. S slow motion dials and drives, chassis, panels, cabinets, nuts and bolts, rotary switches, electrolytics, miniature components, resistors, etc.; extensive range of components, American and British valves, Vitavox speakers and microphones, Sound Sales feeder units and amplifiers, Gardner transformers, radio circuits and manuals, etc., etc.; Eddystone stockists; catalogue 2/6d post free—Whatever you want, write City & Rural Radio Constructional Engineers, 101, High St., Swansea, Tel. 4677. [9437]

CONDENSERS: 0.1mfd. 2,500v v. tubular, 8/- dz.; 0.1, 10,000, oil filled, 10/- ea.; 0.5, 1,000, paper, 8/- dz.; 4, 1,000, paper, 2/9 ea.; 4, 350, paper, 8/- dz.; Amphenol valve holders, i. octal, English octal, 7-pin, Eng. and U.S., 5/- dz.; Selenium rectifiers, 160v 40ma 2/6; Westinghouse 300v 120ma, 7/6 ea.; Yaxley switches, 2-pole 2-way, 2-pole 10-11-way, 2/6 ea.; camera control units, comprising fractional h.p. a.c.-d.c. motor indicator units, relay power solenoid, etc., 22/6 ea.; s.a.e. for full lists; orders under £2 2/6 p. and p.—Norvall, 154, Selkney Hatch Lane, N.10. Tudor 4389. [9358]

SPECIAL this month!—Europa superhet radio S chassis, 5-valve ac/dc, medium and long or medium and short, fully wired, aligned and tested ready to switch on, overall 11 1/2 x 6 1/2 x 5 1/2 in. p.m. speaker dial, drive on chassis ready to slide into cabinet, inductances iron-cored, splendid performance, brand new, guaranteed, £6/5, carr. 2/6, set of valves £3/7; also Overseas 5 superhet assemblies, L.M. & S. ac model, £6 17/6, ac/dc, £6, speakers and cabinets available; send postage now for full details of these and other bumper "W.W." bargains—N.R.S., 66 & 102, Parkhill Rd., London, N.W.3. Guliver 1453.

SPECIAL notice.—The famous range of A.I.S. Products are now being manufactured by the London Television Co. Ltd. They conform in every respect to the original specifications, also the delivery position is greatly improved, most lines being available ex-stock. 40 coil pack, a superhet coil pack with h.f. stage, uses 9 iron-cored coils in 16-50, 200-550 and 800-2,000 metres circuit, 465 kc/s i.f., aligned and gain tested, with circuit diagram, enables amateur with no signal generator to construct first class all-wave receiver, price £3/10, circuit diagram on v. 2/6; send stamp now for price list and technical bulletin W.I.; enquiries promptly dealt with and demonstrations given at our showrooms, Tel. Ley. 4330 for special information.

THE LONDON TELEVISION Co., Ltd., 694, Lea Bridge Rd., London, E.10. [9425]

GEE ELECTRIC, 15, Little Newport St., London, W.C.2. Tel. Ger. 6794—Variable condensers ceramic insulated, single gang 0.0005, 2/6, 2-gang ditto 7/6, 3-gang ditto 8/6, 4-gang ditto 9/-; all standard 1/2 in spindle; 0.001 5 kW condensers, 1/6; 0.5 HFD 2,500 VV condensers, 5/-; Varley P/P input heavy duty transformers, rat. 2.51+2.51, 12/6; G.P.O. type sockets, 3-way, all metal, 1/6 3/4; new 230v cycle mains transformers, 280-0-280, 120 m.a. 5v 3 amp, 6.3v 7 amp, with fixing feet, 38/6; good quality s/screened wire, 9d yd. T/screened, 1/- yd; and 5-core 1/- yd, 7-core 1/3 yd. as previous advert.; also very large and comprehensive range of all types of new valves in stock; special prices quoted for large quantities to the trade. [9381]

CONDENSERS—0.1 mfd 350v tubular, 3/9 doz. 40/- gross; 1 gross assorted moulded and silvered mica, 30/-; postage stamp trimmers, 4-40 mmfd, removed from coilpack assemblies, 2/6 dz. 24/- gross; metal rectifiers, small size, 250v 80ma, 4/- ea. 42/- doz.; smoothing chokes, 80ma, 4/- ea. 44/- doz.; Mallory 12v vibrators, 7/6 ea.; mains transformers, 200-250v input, 8-9v output, suitable eel bell or chimex, 6/- ea.; aluminium chassis, 10-5 1/2 x 2 1/2, ea. drilled to spec, 5/-; 40v electrolytics, 2 1/2 dz. 2 gangs 0.0005 mfd with feet and epicyclic drive, 8/6 ea.; cabinets, 12 1/2 x 7-6 1/2, polished wood (walnut) attractive appearance, supplied with speaker fret and suitable dial, 28/6; c.w.o. or c.o.d. over £1.—Radio Supply Co., 19, Lidget Hill, Pudsey, Leeds. [9455]

VALUE!—Matt has it, special offers: Hand-phones, w/lead and jack plug, 5/- pair (boxed 2 pairs), 54/- doz pairs; silver mica condensers, asstd values, 2/- doz. 20/- gross lots; fixed condensers, metal block type, .03, .15, .2 and .5mfd, 200-400 wgs., 2 each, 10/6 doz; variable condensers, .002 2/6 doz, .0006 3/- doz, .001 9/- doz, 8mfd 4/6, 8+8 canned 6/6, 16+8 canned 8/-, 75mfd 12v wkg, 2/- each, 4+4 block 3/-; speakers, P.M. (less trans), 5in 14/-, 6in 24/-, 8in 27/6, trans to match 5/6; multi radio do, 5 v, vol. controls all values (Centralab), 1 s. 3/6, w.s. 4/2; line cord, 3amp 60ohms, 10ft, 2-way, 1/6vd; 3-way, 2/- yd; tuning condensers, .0005 Polar Midget 11/6, .0005 standard 5/6; soldering irons, Stanelco, 12/6 ea; mains trans., 350/350 80ma, 4v, 27/6, 6v, 28/6; postage extra. Largest assortment of valves always in stock, let us have your enquiry.

MATT RADIO SERVICE, 29, Castle St., Kingston-on-Thames, Surrey. Kingston 8353. [9545]

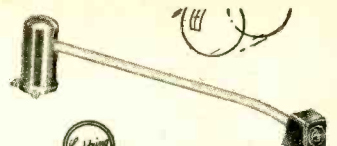

GOLDRING Light Weight PICK-UP

WITH JEWEL POINT SAPPHIRE NEEDLE

The Latest GOLDRING Pick-up No. 121 has many great advantages, including—

- Full Frequency Reproduction in combination with a standard Wireless Set.
- Will abolish constant needle changing.
- Will safeguard records through reduced wear.

Write for full descriptive leaflet

ERWIN SCHARF
49-51a, De Beauvoir Road, London, N.1

Telephone: CLIssold 3434

POTENTIOMETERS

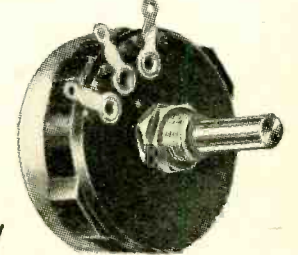

by **RELIANCE**

Type T.W. Wire Wound	
Rating	RANGES
5 Watts Max. (linear)	10-100,000 Ω Max. (linear)
3 Watts Max. (graded)	100-50,000 Ω Max. (graded)
	100-10,000 Ω Non-inductive
Type S.G. Composition	
1 Watt Max.	2,000 ohms to 2 megohms

CHARACTERISTICS: (both types) linear, log., semi-log., inverse log., non-inductive, etc.

FULL DATA FROM:
RELIANCE
Manufacturing Co. (Southwark) Ltd., Sutherland Rd., Higham Hill, London, E.17.
Telephone: Larkswood 3245

TANNOY CONCENTRIC Dual Loudspeaker System

represents a notable advance on the more orthodox types of Twin Loudspeakers.

Basically, it consists of two units (direct radiator L.F. unit, and Horn Loaded H.F. unit) fed from a carefully designed frequency electing network.

Note the following advanced design points:—

- 1 Use of new anisotropic magnet materials.
- 2 L.F. Cone surround specially treated to prevent sub-resonances.
- 3 Low intermodulation products.
- 4 Frequency response ± 3 dB, 40 c.p.s. to 12,000 c.p.s.
- 5 Freedom from frequency modulation.
- 6 Small size. Diameter 15". Depth 11". Weight 35 lbs. including matching transformer and cross-over network.

Further details readily obtainable from Dept. AA

GUY R. FOUNTAIN LTD.

"The Sound People"

WEST NORWOOD,
LONDON, S.E.27

(Gipsy Hill 1131)

The Largest Organisation in Great Britain Specialising SOLELY in Sound Equipment

G. A. RYALL, 65, Nightingale Lane, London, S.W.12.—Mail order only, postages extra. c.o.d. £1 or over, please send large envelope for our full list; U.S.A. make metal cased 500v tubular 1mf, 7/6 dozen; silver mica, 200pf, 300pf, 400pf, 500pf, 4/6 dozen; 500v wkg. micamoulded 0.004mf, 4/- dozen; mica 0.01mf, 3-2/-; Mansbridge 1mf 500v wkg., 3-2/-; all condensers guaranteed; Amphenol type British 5-pin valve holders, 4/6 dozen; U.S.A. paxolin 4-5-6-pin, 3/6 dozen; valve controls, 10 000 medium spindle, 1/6; 250.000ohm short spindle, 1/6; bar type 3-gang, 0.0004mf short spindle, 5/-; bar type 4-gang 0.0004mf, 5/-; resistors, 1/2 watt, 1/2 watt, 100ohms to 2meg, level assortment, 40-5/-; plastic group boards, drilled, less tags, 9w types, 1/6; switches, SB, 2p 1w; miniature circular switches, 2/-; 3B 2p 6w 5p total, 2/6; 3B 3p 3w, 2/3; res. panels, 5w with 25mf 12v and 3 res., 1/3; 12-way group boards with 9-1watt and 1/2 watt res., 2/-; all new; 20 types in stock; octal plugs, cap and socket, 3-2/6, with tags 3-3/-; high resistance phones with sponge earpads, with good class microphone, all wired into plug, rubber padded, plug type 10H/10991, 10/9 pair; metal boxes, black finish with 1/4in paxolin panels, fixing lugs and corner sockets, size 8 1/2 x 7 1/2 x 3 1/2 in deep, 6/9 each complete; international octal valve holders, paxolin chassis type, 4/6 dozen; metal-cased tubulars, 0.5mf, 350v, at 71d C. wire ends, 8/6 per dozen; 15 relays in carrying rack, mounted, with cover, 30/- each. 18928

SURPLUS W.D. goods. Knock-out prices to traders and others; examples, 2,000 heavy 2-way 20 amp switches, 1/11; 2,000 horn pushes, 1/3; 5,000 aircraft sparking coil valve holders, wire or racing, worth 30/-, our price, 18mm, 1/11, ditto, all chrome, 2/6, 14mm, plated, platinum point, 4/6; 20,000 rheostats, 1/-; bromide paper contrast, 10x10, gross boxes, 42/-; 5X3 1/2 post-cards, 6 gross box, 50/-, sample packet 24 for 3; garage, 1 parcel of 300 items, 34ugs, switches, rheostats, dot fasteners, etc., £10 for £2; electrical traders or experimenters parcel, £10 worth for £2; money back guarantee; all post paid; 3d in stamps and s.a.e. for extensive well illustrated list.—J. Milligan, 9, Long Lane, Garston, Liverpool. 19439

NEW S.T.C. selenium rectifiers. F.W. bridge con., latest damp-proof finish, 17v 1.5a 12/1, 2a 15/5, 3a 21/6, 4a 25/-, 5a 27/-, all p.f.; 33v 1.5a 28/-, 2a 29/6, 3a 35/-, 4a 42/-, 5a 43/6; 50v 4a 54/-, all p. 10d; heavy duty type, 7in sq cooling fins, 17v 6a 34/1, p. 1/-, 16v 10a 43/3, p. 1/-, 33v 6a 64/-, 10a 71/-, 28v 20a 140/-, 28v 30a 207/6; 54v 6a 90/-, 90v 6a 142/-, 110v 6a 166/-, all p. 1/4; industrial type, funnel cooled 33v 6a 69/-, 10a 80/-, carr. 1/6, and many others up to kW sizes; conversions for v.v.e. choppers; Philips type 567 and Tungar, 68504 and 68530 (U600) by return of post; no alteration to charger necessary, fitted in 5 mins; please state type No., make, a.c. volts input and d.c. amps when inquiring; we can supply specialised rectifying equipment for labs., schools and technical colleges; in bridge, F.W., doubler and push-pull connection, quotations by return; kits, comprising rect., trans. and rheostat, 54v 6a £11/10 (incl. tap selector switch); 33v 6a £7/19/6, 16v 10a £6/12/6, 17v 6a £4/12/6, 16v 5a £3/2/6 (vent. steel case 7/6 extra), 16v 4a £3, case 7/6, 16v 2a 38/6, case 2/6; transformers, 220 watt for 16v 10a 65/-, p. 1/4; 17v 6a (130w) 47/6, p. 1/4; 16v 5a (110w) 41/6, p. 1/-; 16v 4a (90w) 35/6, p. 1/-; 16v 2a (40w) 23/6, p. 10d; slider resistances, all values, 150 watts 24/6, p. 9d; 0.4 ohm 25a 27/6, p. 1/-; other forms c.o.d. post goods only; others c.w.o. or pro-forma invoice; trade supplied; new list now available, s.a.e.—Pearce, 66, Gt. Percy St., London, W.C.1. Nr. "Angel." Est. 16 yrs.

SELENIUM h.t. and l.t. rectifiers, foolproof charger kits, speakers, mikes, etc. Add 7d postage up to 15/- 1/3 above. Informative data sheet with all rectifiers and charger kits. S.T.C. selenium rectifiers, 12v 3amp, 22/-; 12v 4amp, 25/-; 12v 5amp, 27/6; also giant finned 12v 6amp type, 35/-; smaller types, 12v 2amp, 12/6; 12v 1 amp, 10/6; 6v 2 amp, 9/6; 6v 1/2 amp, 5/6; 12v 5amp, 7/6; higher voltage types in stock, including 24v 2.5amp, 36/6, 24v 5amp, 44/6; many others. New small space type selenium h.t. rectifiers for converting a.c./d.c. sets to metal rectifier, 250v 60ma or 110v 60ma, 9/6; 350-0-350v 80ma, 13/6; eliminator type, 120v 20ma, 7/6; or with mains transformer, 2v trickle charge rectifier, two 8mf condensers for 120v 20ma eliminator, 39/6. New Germanium crystal diodes, 3/9. Charger kits, no rheostat or ammeter required. S.T.C. 12v 5amp rectifier with 50watt transformer and ballast bulb for 2v to 12v charger, 62/-; ditto but with 2amp rectifier, 36/6; ditto but 6v 2amp rectifier for 2v, 6v charger, 35/-; ditto with 6v 3amp rectifier, 42/6. Mains transformer, 75watt with 12v 4amp rectifier and ballast bulb for 2v to 12v charger, 62/-; ditto but giant 6amp rectifier and 10watt transformer for 6v 12v charger, £5; 2v, 6amp trickle charge rectifier with transformer, 13/6; 6v 1.5amp rectifier with 25watt transformer, 26/-; Heavy duty charger kit for small radio store for continuous use, one to 20 cells at 1amp, £4/15; ditto but 2amp £6/15; cyanan lead one year, 0-gamp ammeters, 12/6; 1ohm 10amp slider resistances, 13/6. Rola 8in P.M. speakers, less transformer, 17/6. Lustraphone moving coil microphones, 58/6. 80 watt fluorescent chokes, tapped, 19/6. CHAMPION, 43, Uplands Way, London, N.21. Tel. Lab. 4457. 19410

THE "Q-MAX" Q5/10 COMMUNICATIONS RECEIVER

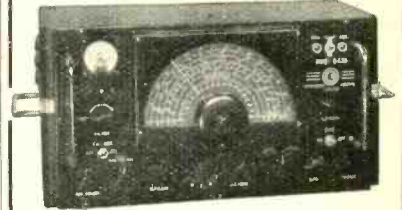

A 10 valve superheterodyne receiver supplied in two models—one covering five amateur bands, 1.7-28 Mc/s. with complete Bandspread and the other for general coverage, 1 Mc/s.-31 Mc/s. continuous in five overlapping bands.

Price £52 10s.

(Plus Purchase Tax)

THE "Q-MAX" B4/10 TRANSMITTER

A complete 40 watt—Four Band Transmitter for Phone or C.W.



Transmitter

Price £75

THE "Q-MAX" SHORT WAVE ALL-DRY 4



An All-dry straight short wave receiver covering wavebands from 11 to 350 metres and using plug-in coils.

Price 12 Gns.

(P.T. £4 6s. 1d.)

Our New Illustrated Catalogue Is Now Ready. Price 3d.

BERRY'S
(SHORT WAVE LTD.)
25, HIGH HOLBORN, LONDON, W.C.1
(Opp. Chancery Lane) Tel.: Holborn 6231



**THIS USEFUL
NEW FOLDER**

tells you all about the complete range of Henley SOLON Electric Soldering Irons, for the standard voltage ranges of 200/220 and 230/250; 65 watt and 125 watt models fitted with oval-tapered bits and pencil bits and 240 watt models fitted with oval-tapered bits are available.

Write Today for the new folder ref. Y.10 describing

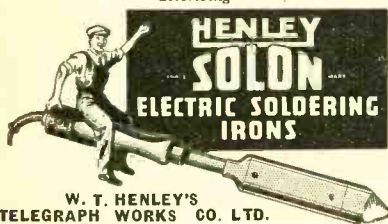

**W. T. HENLEY'S
TELEGRAPH WORKS CO. LTD.**
(Engineering Dept.)
51-53 Hatton Garden, London, E.C.1

GOVT. SURPLUS, UNUSED

**CONDENSERS
of all types . . .**

We can offer, FOR IMMEDIATE DELIVERY from very generous stocks, a wide range of ultra-high quality fixed paper Condensers, from .001µF to 8µF. Also STOCKS of small, genuine MICA Condensers from .00001 (10 pf) to .01µF (10,000pf). Prices are exceedingly moderate.

Enquiries are invited for manufacturers requirements, wholesale and export only for bulk quantities, and for scheduled deliveries over a period, as required.

Condensers of close or very close tolerance can be supplied within about one week.

Please request our 4 page bulletin CONSEVEN 01114

CLAUDE LYONS LTD.
180, Tottenham Court Rd., London, W.1
and 76, Oldhall St., Liverpool 3, Lancs

SUPREME RADIO, 746b, Romford Rd., Manor Park, London, E.12.—Last month's bargains of electrolytics nearly cleared, "cannot repeat," don't be late for the last of them: 8mf, can or card, 5/6; 4mf, screw can type, 550v w. 15/- doz; 50-12v w. can, 1/3 ea; 0.5mf 350v w. 9/- doz; 0.25 350v w. 9/- doz; 8mf, can, 750v w. 4/6 ea; condensers, cardboard, 0.01 1,000v w. 5/6 dz; 0.05 350v w. 5/6 doz; 0.1 350v w. 5/6 doz; 0.2 750v w. 5/6 doz; variable trimmers, single 50pf 7d each, double 140pf 1/2 double 50pf 11d; fixed condensers, mica, 0.005, 0.1 80pf, 325pf, 590pf, 305pf, 570, 4,550pfs, all at 2/6 doz; w. resistances, 100, 150, 200, 300, 400, 500, 2k, 2.2k, 5k, 10k, 20k, 100k, 250k, 500k, 1.5k, 2m, these in dozens or assorted, 2/- doz, 21/- gross, only while stocks last; also 1/4w 100, 220, 350, 1,000, 3.3k, 4.7, 10k, 15k, 20k, 40k, 47k, 100k, 1m, 2m, 2.7m at 3/- dozen, all well-known make; 1w, 20k, 27k, 4/- doz; 5w 10k, 5/6 doz; Mazda Octal valve-holders, bakelite or Paxalin, 2/6 doz; 4-pin U.X. ceramic, 1/- doz; U.S.A., 4/6 doz; volume controls, standard size, long spindle with sw 100k and 50k, 36/- doz; 5k up to 2meg, 4/- ea; 250k less sw, 23/- doz; 2,000 W. less sw, 12/- doz; standard grid caps, 6d doz; 0005 reaction condensers, 12/- doz; Westectors, 1/8; pick-up jacks, 1/-; valve screen cans with cap and base, 12/- doz; ear-phones with head band and lead, 50/-, 4/8 pair; high resistance, 2 pair; telephone inserts, 2/6; ear-phones, 2/6; 2/6; anchoring tags on Paxalin panels, 3/- gross; Paxalin panels with tags, 3 ways, 1d; Xalloy sw 3-pole 3-way, 3/-; many other lines not listed; send 2 1/2 s.a.e.; terms c.w.o., no c.o.d.; 6d extra postage all orders under £5.

RADIO CLEARANCE, Ltd., 27 Tottenham Court Rd., London, W.1.—10-valve P.P. R.1481, range 4/- ea; 250k less sw, 23/- doz; (VR66) mixer (VR65), 3 I.F.s (VR53), det. and A.V.C. (EB34), A.F. (VR57), output (VR67), 6in s.m. dial, B.F.O., tuning meter, R.F. and L.F. gain controls, requires P.P. 250v h.t., 6.3v i.t., all brand new, in wooden transit cases, as our previous lot, and we are now bid to offer these sets, which lend themselves readily to modification for 5 mtes., F.M., etc., at £7/19/6; circuit diagram supplied with each receiver, carriage pad; power packs, type 3, these are for the above sets, 19in rack fitting, input adjustable by switch, 200-250v a.c., 50 c/s, with voltmeter and milliammeters; we have a few available for sale only with sets at £2/19/6; R.F. units, type 24 and 25, these units have 3 valves (VR65), R.F., mixer, osc., and 5-position ceramic switch (3-bank), giving 5 freqs. approx. between 35-45 m/cs (type 24 slightly lower); I.F. output 7.5 m/cs, make useful converters, supplied complete with valves, 17/6; post paid meters, all moving coil, 0-1 ma, 2in square, 7/6; 0-10 ma, 2in square, 7/6; 0-30ma, 2 1/2in circular, 7/6; 0-50ma, 2in square, 6/-; 0-150ma, 2in square, 8/6; 0-500 micro amp, 2 1/2in circular, 19/6; 0.3a R.F. ammeters, 2in square, 6/-; all these are flush mounting, 0-750 micro amp, 2 1/2in circular, plug-in, calibrated for use with thermo couple as radiation meter, 7/6; Mansbridge condensers, 0.1 5,000v (6 1/2in x 3 1/2in x 2 1/2in), 5/6; 4mf, 1,000v, 4/6; 10mf, 500v, 5/6; 1mf, 1,000v, 1/-; 2mf, 300v, 10d; 0.25mf, 2,000v, 1/9; 0.5mf, 1,200v, 1/-; all w/gv voltages; smoothing chokes, 5h, 200ma, res 90Ω, 8/-.

PARK RADIO OF MANOR PARK, 676, Romford Rd., E.12, offers Fountain Pen Electric soldering irons, 9/- each, plug into valveholder; tungsten contacts for repairing vibrators, 1/6 pair; pick-up bobbins for repairing Garrard and other pick-ups, 4/9 each, including rubbers; Pye co-ax plugs and sockets, 1/- pair; feedthrough type, 9d each; large 12-pin sockets, 9 and 15 centre, 2/-; noise suppressors for dirty mains, fit one in cable lead, 5/- pair; chromium air vents for amplifiers, 1 1/2in overall, 1/- each; 16 toggle switches on one panel, 4/6; 4-pin bakelite plug to fix in 4-pin valveholder, 1/- each; trickle charger kit for home construction, 12/6; output 2 or 4v d.c. from 250v mains; difficult valves delivered from stock, impossible valves within a few days, all valves at Board of Trade prices; brand new telephone handsets, earpiece and mike with fingertip switch bar in handle, 7/6; 1,000ohm wire-wound 5watt Colvern potentiometers, 1/- each; twin gang 15pf condensers for ultra-short wave, 2/- each; 100pf ditto for short wave, 2/6; single 75pf can be ganged 2 or more 2/6 each; transformers, 230v input, 1,100v output, 12/6 each, output voltage can be doubled, good for television or oscilloscope use; 250v a.c. d.c. motors, suitable for adapting to sewing machines, coilwinders, aquarium pumps, etc.; brand new and made by Hoover, 15/- each; Wearite P coils, complete range stocked, at 3/- each; contact mikes suitable for pianos, guitars, etc., 2/6 each; suitable transformer, 6/-; throat mics, 3/6 set, moving coil microphones, 4/11; suitable transformer, 8/-; 0-60microamp meters, two in one case, 7/6 each; 0-500 ditto, 7/6 each; orders by return for 1/4, 1/4, 1, 3, 5, 10, 20watt resistors, and all values mica, ceramic, bakelite or electrolytic condensers; moving coil pick-ups, no preamplifiers required, £2/10/4; headphones, balanced reed to spin minimum diaphragms made by either S.G., Brown or Pesseys, 4/11 pair, with jack plug; super-sensitive relays, work at 1 1/2 volts, c.consumption 1ma, 5/-; self-energising micro-telephones, also suitable for use as extension speakers, no mains or batteries required, 2/6 each; all goods previously advertised [9290 available.

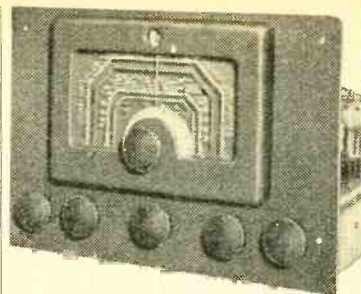

**PEERLESS
TYPE 1047 RADIO CHASSIS**

This chassis is now available as an AC/DC model, and can also be supplied as a complete Radio Gramophone with twin speakers, acoustic labyrinth, etc., in walnut cabinet by one of Britain's leading designers.

Among its principal features are:—

- 10 stage superhet circuit.
- 10 valves (including magic eye).
- RF amplifier.
- 2 IF stages.
- 4 wave bands.
- 10 Watts push-pull output.
- Tropicalised components.

Communications enthusiasts should write for details of our 1546 Chassis.

PEERLESS RADIO LIMITED
374, Kensington High St., LONDON, W.14
Phone: WEStern 1221

LASKY'S RADIO

Owing to popular demand we are again offering the Ex-Army Type 19 transmitter/receiver.

Receiver and B set utilizes 12 valves, six 6K7, two 6K8, two 6V6, one 6H8, one E1148(CV6), 4 gang tuning condenser, B.P.O. relay, etc.
Receiver Frequency 2.8 Mc/s. In two bands.
B set Frequency 235 Mc/s.

Transmitter uses 3 valves, one 6H6, one EF50 and one 807. Freq. 2-8 mc/s, single .0005 tuning condenser, 0-5 m/a. Moving coil meter for tuning and voltage checking operating C.W., M.C.W. and R.T.

In strong metal cabinet, front panel enamelled grey, all controls clearly marked. Size 10in x 17in x 8in. Weight 35 lbs. Made by Leading Manufacturers.

Lasky's Price less power pack and valves, 45/-
Carriage England and Wales, 5/- extra. (No C.O.D.). As above, less 0-5 m/a meter, 35/-.

Ex Am. Receiver Type R1125A. As used in B.B.A. equipment marker Beacon receiver. Containing two valves, (equivalent to Brimar 802), Ceramic valveholders, 2 potentiometers, transformers, condensers and resistances, etc. Enclosed metal case, size 10in. x 6in. x 2 1/2in., weight 4 lbs.

Lasky's Price 15/- each. Postage 2/- extra.
Moving Coil Meters, 2 1/2 inch round, 0-1 amp. and 0-20 amps, 7/6 each. Postage 6d.
Brand New, Boxed by leading manufacturers.

Send 1d. stamp for our current list of radio components.
Also our latest bulletin of Ex-Government bargains.

It will pay you to pay us a visit.

LASKY'S RADIO
370 HARROW ROAD
PADDINGTON, W.9
Telephone: CUNningham 1979

Hours: Mon. to Sat. 9 a.m. to 6 p.m. Thurs. half day

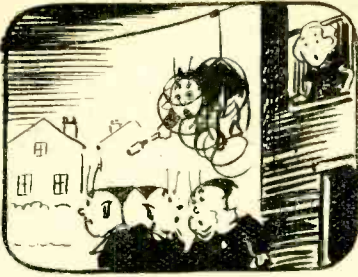

THE "FLUXITE QUINS" AT WORK

"Our lad's a long time at the store, He should have been back long before; We need that FLUXITE To fix this wire tight, He's held up somewhere, that I'm sure."

See that FLUXITE is always by you - in the house - garage - workshop - wherever speedy soldering is needed. Used for over 40 years in Government works and by leading engineers and manufacturers. Of all Ironmongers—in tins, 10d., 1/6 & 3/-.

TO CYCLISTS! Your wheels NOT keep round and true unless the spokes are tied with fine wire at the crossings AND SOLDERED. This makes a much stronger wheel. It's simple—with FLUXITE—but IMPORTANT.

The FLUXITE GUN puts FLUXITE where you want it by a simple pressure. Price 1/6, or filled, 2/6.

ALL MECHANICS WILL HAVE

FLUXITE

IT SIMPLIFIES ALL SOLDERING

Write for Book on the ART OF "SOFT" SOLDERING and for Leaflets on CASE-HARDENING STEEL and TEMPERING TOOLS with FLUXITE. Price 1d. each.

FLUXITE LTD. (Dept. W.W.), Bermondsey Street, S.E.1

LARGE quantities high grade tropicalized Paper block and tubular condensers, various values; 500 first grade M.C. meters 0-200ma, 3 1/4 in diam., round panel mounting, new and boxed, £450 the lot; 600 Bulgin toggle switches, d.p. two-way, new and boxed, £60 the lot; 800 wafer switches 2-pole 6-way, new and boxed, £40 the lot; 5,000 metal telephone jacks, 2 contact, £100 the lot; 1,000 Pantin vitreous resistors, 100 300 10,000 ohms, 250 watt, £50 the lot; 10,000 iron dust cores, size 1 1/2 x 3/16 in diam., offers; 500 vitreous resistors, 250 ohm 12 watt, with clips, new and boxed, £25 the lot; 600 465 kc/s midget dust cored I.F. transformers, £125 the lot; 200 m/c condensers, 0-300ma, 2 1/2 in square panel mounting, £100 the lot; 2,000 P.O. single push switches with knob, DP/DT, £50 the lot; 2,000 2-speed slow motion drives with knobs, £50 the lot; 14 Admiralty contactors, 100 volt coil contacts, 2 change-over, 30 amp, £14 the lot; 5 mica condensers, 0.005 mfd 5,000 volt dc, for 60 m/c's at 1a, offers; 1,000 chokes 650 micro henry, £5 the lot; 100 750 ohm 20 watt carbon resistors, £5 the lot; approximately 1/2 million Simmonds nuts, various sizes, offers over £100; 1,000 heavy duty rubber mounting, offers.

BUICK enquiries only to Bargain Radio Stores, 72, Cape Hill, Smeeth, Essex, S9 9SD. SPEAKER trans, tapped output, ultra-midget 5/-, midget 5/6, standard 8/-; P.P. output (6L6 valves, A.A. load 6,600ohms), output 7.5 and 15ohms, 2 1/2-; P.P. modulation trans, for 807 valves, audio power, 30watts, 2-1, at 12/6; 807 valves, ultra-midget 40ma 5/-, midget 50ma 5/6, standard 100ma 8/6; hy. duty 150/200ma, 12/6; "Ruco" tuning assembly, assembled and fully wired for s.m.l. waves. On chassis, dial, pointer, i.f.s. coils, padders, etc. Series heater wiring for use with 68k8, 6k7g valves, complete, factory tested and aligned, with output 25, 5w superhet, fully drilled chassis, 1 1/4 x 5 1/2 x 2 1/2 in, 7/-; Weymouth midget i.c. i.f. trans., 465kc/s, brand new, pr. 18/9; standard i.f. trans., pr. 15/-; ditto i.f.s. 2mc/s, each 2/-; m.l. t.r.f. coils with reaction circuit, pr. 7/6; m.l. i.c. i.f. t.r.f., pr. 16/-; m.l. i.c. i.f. t.r.f., pr. 10/-; sleeving, all colours, 1m/11, 35/40 yard reels, 5/6; twin variable resistance, 3000ohm, lamp 25/-; Yaxley type, 3-pole 2-way 2/-, 4-pole 3-way 3/-, 4-pole 4-way 3/6; nice type DPDT, 2/6; comprehensive lists monthly, 2 1/2d. stamp enquiries, postage extra, all orders.

O. GREENLICK, 265, Whitechapel Rd., London-E.1, Tel. Bishopsgate 5907. [8799]

WANTED, EXCHANGE, ETC. WANTED, 1 ton 23 swg enamelled copper wire; state price.—Box 6255. [9473]

WANTED 2 Taylor 203A valves.—Cook, 51, Cavendish St., Chesterfield. [9368]

WANTED, 22 valve Motorola Silver receiver.—1, Bridgefield Rd., Gateacre, Liverpool. [9284]

WANTED, W.W., July, 1946, describing R1155—Trubshaw, 15, Trinity Sq., E.C. [9436]

WANTED, service manual for the R.G.A. AR388, com. box 626, price paid.—Box 6266. [9436]

WANTED, 100-150w TX, Blue Diamond generating unit; vibrator unit for B2 and No. 17.—B.M.E.K.Y.V., London. [9470]

WANTED, service sheet for Murphy A92, condition and price to.—Smithers, 3, Queens Rd., Knaphill, Woking, Surrey. [9352]

DISC recording equipment wanted; also vinyl recorder.—Details, prices to Rushworth, Church House, Shiremoor, Northd. [9444]

WANTED, com. rec. also good quality feeder unit and loud speaker.—Hardwick, 168, Cauldwell Hall Rd., Ipswich, Suffolk. [9436]

LARGE quantities new telephone handsets, P.92-core P.V.G. cable, 6 or 12 volt, P.O. jack lamps and holders.—Details to Box 6263.

WIRE recorder wanted, playback and wipe-out essential, must be suitable musical reproduction.—7, Westchester Hse., Seymour St., W.2. [9240]

MULTIPLE coil winding machine required; send full particulars.—Taylor Electrical Instruments, Ltd., Montrose Ave., Slough T1381.

EX-SERVICE valves wanted, equiv. to EF39, EF36 and EL32, any quantity; all letters answered.—N. R. S., 66, Parkhill Rd., London, N.W.3. [9240]

ENAMELLED copper wire, all gauges wanted urgently, no quantity too large.—Simmonds, 10, Valencia Rd., Stanmore, Middx. Grimsdyke 608. [9482]

V.G. 78 33 1/2 motor required, with or without tracking gear, price very exceptionally good.—price to BCM/KATHERINE, c/o 3, Bloomsbury St., W.C.1. [9216]

WE buy for cash, new, used, radio, electrical equipment, all types; especially wanted, radios, radiograms, test equipment, motors, chargers, recording gear, etc.—If you want to sell at the maximum price call our wire or phone to University Radio, Ltd., 22, Lisle St., Leicester Sq., W.C.2. Ger. 4447. [7667]

REPAIRS AND SERVICE MAINS transformers rewound, new transformers to any specification.

MOTOR rewinds and complete overhauls; first-class workmanship, all guarantees.

F.M. ELECTRIC Co., Ltd., Potters Bldgs., Warsar Gate, Nottingham, Est. 1917. Tel. 3355.

LOUDSPEAKER repairs, British, American, any make, moderate prices.—Sinclair Speakers, 12, Pembroke St., London, N.1. Tel. minus 4355. [3308]

LOUDSPEAKERS repaired; clock coils. Chokes rewound; prompt attention; prices quoted.—E. Mason, 5, Balham Grove, Balham, London, S.W. [7667]

GALPINS

ELECTRICAL STORES, 408, HIGH STREET, LEWISHAM, LONDON, S.E.13 Telephone: LEE GREEN 0309. (Near Lewisham Hospital).

TERMS: CASH WITH ORDER. NO C.O.D.

MAINS TRANSFORMERS (AUTO WOUND). Voltage Changers tapped 10, 20, 25, 90, 130, 150, 190, 210 and 230 volts, all at 1,000 watts, a combination of 34 voltages can be obtained from this Transformer, new ex-Govt. stock, £5/10/- each, carriage 5/-. Mains Booster Transformer, tapped 0, 6, 10, 19, 175, 200, 220, 225, 240, and 250 volts at 1,500 watts (new ex-Govt.), £5/5/- each, carriage 5/-. Another 200 volts input, 240 volts output at 2,500 watts, £7/10/-, carriage 7/6. Another, 2 to 1 ratio, 110 volts input, 220 volts output, or vice versa, at 4,000 watts, £12/10/-, carriage 10/-. Another, 230 volts input tapped output 40, 41, 42, 44, 46, 47, 49, and 52 volts at 100 amps, £15 each, carriage 10/-. The latter two are double wound. Another auto wound, tapped 0, 110, 150, 190 and 230 volts at 1,500 watts, £6/10/- each, carriage 5/-. Ditto, 2,000 watts, £7/5/-, carriage 5/-. EX-GOVT. (G.E.C.) ELECTRIC FANS, 12 volts AC/DC laminated field, complete with 5in. impeller. New boxed, 20/- each, 1/- post. Transformer to suit 230 volts input 10/16 volts at 4 amps. output, 32/6 each.

EX-GOVT. (NEW) MAINS TRANSFORMERS, 200/250 volts 50 cys. 1 ph. input 525/0/525 volts 150 M/amps. 6.3 v. 5 a., 5 v. 3 a. output standard rating, 35/-, post 2/-. Mains Smoothing Chokes, 10 Hy. 150 M/amps. 180 ohms D.C. Resistance, 8/6 each. Ditto, 100 M/amps. 5/6 each, post 9d.

EX-R.A.F. MICROPHONE TESTERS (new). These consist of a FERRANTI 0 to 450 Microamp 2 1/2 in. scale meter shunted to 1 M/A incorporated Westinghouse Rectifier, the whole encased in polished teak case calibrated at present 0 to 10 volts, 32/6 each.

SPECIAL OFFER METERS, ALL NEW BOXED. Moving Coil First-Grade Instruments, 0 to 20 volts, 10/- each, or 3 for 25/-; 0 to 40 volts, 12/6 each; 0 to 10 amps, 15/- each; all 2in. scale. 0 to 20 volts A.C. calibrated 50 cys., 25/- each; 0 to 4 amps. Thermo Coupled, 25/- each; 0 to 3,500 volts Electrostatic, 35/- each, all 2 1/2 in. scale.

EX-R.A.F. IFF UNITS. As new, these units contain 10 valves S.P. 41s, Ef 50s, Ea 50s, etc., also approx. 100 resistances and condensers, also complete with motor generator, 12 or 24 volts input, 450 volts at 50 M/amps. output. To clear, 24-volt type, 35/-; 12-volt type, 42/6, carriage 3/6. EX-R.A.F. RF UNITS (new), packed, containing 6 valves, all 6.3 heaters, including grounded grid triode, also a miniature 24-volt motor (universal) and approx. 80 resistances and condensers, all mounted on silver-plated chassis, to clear, 45/- each, carriage paid.

MAINS TRANSFORMERS (NEW). Input 200/250 volts 50 cys. 1 ph. output 350/0/350 volt, at 180 M/amps. 4 v. 4 a. C.T. 6.3 v. 4 a. C.T. 5 v. 3 a., 37/6 each, post 1/6; ditto, 500/0/500 v. 150 M/amps. 4 v. 4 a. C.T. 6.3 v. 4 a. C.T. 5 v. 3 a., 47/6 each, post 1/6; another tapped 6, 12 and 24 volts at 10/12 amps, 45/- each, post 1/6. Auto wound Voltage Charger Transformers, tapped 0, 110, 200, 220 and 240 volts 250 watts, 45/-; 350 watts, 55/-; 500 watts, 70/- each, carriage 1/6. (Please note, these Transformers can be delivered 10 days from receipt of order.)

MAINS VARIABLE RESISTANCES (New ex-Govt. Stock) Slider type 14 ohms carry 1 to 4 amps., graduated useful as dimmers, etc., 25/- each, post 1/-. Another, 0.4 ohm, carry 25 amps., 22/6 each, post 1/6. Ditto 450 ohms 0.7 amps., 27/6 each. Ditto, 5.7 ohms 8 amps., 27/6. Ditto 4,000 ohms 0.25 a., 32/6 each. Ditto 60 ohms 1 1/2 a., 25/-.

EX-GOVT. (G.P.O. pattern) HANDESETS combined Microphone, Earphone, black bakelite (new), 10/6 each. Cell testing Voltmeters, 3-0-3 volts moving coil (new), 25/- each.

ELECTRIC LIGHT CHECK METERS (for garages, sub-letting, etc.), 200/250 volts 50 cys. 1 phase, 20 amp. load, 25/- each, post 2/-. Ditto, 1 1/2- slot type, 42/6 each, post 2/6. Ditto, 2 1/2 amp. 1 1/2- slots, 30/- each, post 2/6. All fully guaranteed.

MAINS TRANSFORMERS, Ex-A.R.P. Input 230 volts 50 cys., output 12 volts 8 1/2 amps., as new, 25/- each, post 2/6.



**NEW G.P.12
CRYSTAL PICK-UP**

with permanent sapphire stylus
—was fully described in *The Wireless World's* recent article "Crystal Pick-ups—Basis of Design for Fidelity Reproduction."

This remarkable pick-up, which represents the ultimate in high-fidelity reproduction, is now available in limited quantities through your radio dealer, price 96/- incl. P.T.



FREE ILLUSTRATED FOLDER describing this new pick-up may be obtained by returning the coupon below.

TO COSMOCORD LTD.
ENFIELD, MIDD.

Please send folder of ACOS Pick-ups.

NAME

ADDRESS

W.W.

"PERIMET" ELECTRODE
Soldering and Brazing Tool
Operates from 4 or 6 Volt Accumulator or Transformer.



15s. Post free

MAINS TRANSFORMER. 3 Heat. 35s. Post free.
HOLBOROW & CO.,
71, Weymouth Bay Avenue, Weymouth.

A.C.S. RADIO

Specialists in Short Wave Radio and Experimental Equipment, offer a wide range of Components for the home constructor. Our new list, "W" available on request, gives prices and details of all stock lines including the following selected items:—

Feeder Wire, 80 ohm. twin polythene—8d. yd.; 300 ohm. ditto, 10d. yd. Coaxial Feeder, 80 ohm. 1/5 yd.
Wireite "P" Coils, all types, 5/- each.
Transmitting type Coils, air wound, 25 and 56 mc/s, 5/-; 14 mc/s, 6/6; 7 mc/s, 8/-; centre tapped. Bases 1/9.
Fixed Condensers, paper, mica and electrolytic. A large selection available by T.M.C., T.C.C., Dублиer, etc.
Polystyrene Coil Formers, midget type with iron dust core—6d. each.
Loudspeakers, a comprehensive range from 33in. to 12in.; P.M. and M.B. Communications Receivers; the Edlystone 640 Receiver, now tax-free and reduced in list price to today's best seller at £39/10/-.

We also have an ever-changing stock of second-hand receivers, including the NATIONAL H.R.O. and similar types: details on request.

VALVES. A large range of receiving and transmitting valves both British and American makes including the following specialised types: 6AK5, 9001, 9002, 9003, 15A-4; 955 20-; 954 22.6; Eimac 100th £6; RK20A 45/-; VR75/30 and VR105/30 12/6.

Edlystone "S" Meters for Model 640 receiver, £5/5/- Also Headphones, Pick-ups Books, Cabinets, etc., etc. (Postage extra on the above items, please)

Send today for our free List "W", A.C.S. Radio.

44 WIDMORE RD BROMLEY, KENT
Phone: Ravensbourne 0156

MAINS transformer rewound and constructed to any specification; prompt delivery.—Brown, 3, Bede Burn Rd., Jarrow. 13460

REWINDS and conversions to mains and output transformers, from 4/6; pp equipment a speciality.—N. L. Rewinds, 4, Brecknock N.7. Tel. Arnold 3390. 16283

ELECTRICAL measuring instruments skilfully repaired and recalibrated.—Electrical Instrument Repair Service, 329, Kilburn Lane, London, W.9. Tel. Lad. 4168. 16955

BEST instrument repairs. Electrical test and instruments repaired and recalibrated. Quick service, guaranteed work; Avo a speciality.—Electrico, 99, George St., Croydon. 18698

REWIND service which duplicates or modifies as required; transformers, loudspeakers, etc.; prompt returns.—Raidel Services, 49, Lr. Addiscombe Rd., Croydon, Cro. 6537.

SERVICE with a Smile.—Repairers of all types of British and American receivers; coil rewinds; American valves, spares, line cord.—F.R.I., Ltd., 22, Howland St., W.1. Museum 5675.

REPAIRS to moving coil speakers, cones, coils fitted field rewound or altered; speaker transformers, clock coils rewound; guaranteed satisfaction, prompt service; no mains trans. accepted. Closed Sat.

REPAIR SERVICE. 49, Trinity Rd., Upper Tooting, London, S.W.17, Balham 2359.

STURDY rewinds, mains transformers, chokes and fields; we give prompt delivery and guarantee satisfaction: 14 years' experience; prices on request.—Sturdy Electric Co., Ltd., Dipon, Newcastle-on-Tyne. 4516

WARD of Blackheath.—Repairs and modifications to all communication and high quality receivers and amplifiers, autochangers, R.11553, etc.; first-class work only.—Drop a P.C. to Ward, 85, Malt Mill Lane, Blackheath, B'ham. 19359

COILS for rewinds and specials, transformers, L.F., L.P. and R.F. chokes, etc., rapid delivery; 125ma R.F. chokes 2/6 each, 10 Hy. 100ma L.F. chokes 10/6 each; trade enquiries invited.—Carlton Coilwinding Co., Carco Works, 8, Church Rd., Birkenhead. 19443

REWINDING of all types of transformers, L.F. chokes, etc.; quick service; motor windings of all types; replacement bobbins supplied; new transformers to any specification.—Radio & Transformer Services, 570, Manchester Rd., Hollinwood, Lancs. 18658

LOUDSPEAKER repairs, any make, reasonable prices, prompt delivery; to the trade and quality fans; 25 years' experience with Holsa, Magnavox, Godmans, Celestion.—Sound Service Radio, 80, Richmond Rd., Kingston-on-Thames, Kin. 8008.

COIL specialists: Tuning and oscillator coils; L.F., L.P. and mains rewound; 1 day and wound to specification; wave winding, L.S. repairs.—Electronic Services (R.T.R.A.), 17, Arwenack St., Falmouth, Cornwall; and 49, Uxbridge Rd., Ealing, W.5.

REWINDS, mains transformers, speaker field coil, chokes, high-grade coils, rewound; delivery; new transformers constructed to customers' specification, singly or in quantities.—Metropolitan Radio Service Co., 1021, Finchley Rd., N.W.11. Speedwell 3000. 13719

24-HOUR service, 6 months' guarantee, any type transformer rewinds, mains outputs and i.f.s., etc.; all types of new transf., etc., supplied to specification; business heading or service card for trade prices.—Majestic Winding Co., 180, Windham Rd., Bournemouth.

LOUDSPEAKER and transformer repairs "almost by return of post"; we offer the quickest service in the trade, at competitive prices. Send Id for our monthly service bulletin. Dept. W.—A.W.F. Radio Products, Ltd., Borough Mills, Bradford, Yorks. Tel. 22838.

TRANSFORMERS, chokes, coils, etc., rewound and manufactured to order, single or quantity; qualified consulting engineers available to help solve your problems; light engineering, turning, spot-welding, pressing; enquiries for contract work invited.—Millett & Holden, Ltd., 2, Pembury Rd., Westcliff-on-Sea, Essex. 19862

REWINDS—Armature fields, transformers, R pick-ups, vacuum cleaners, gram. motors; speakers refitted new cones and speech coils, all guaranteed and promptly executed. New vacuum cleaners, most popular makes. Send stamped addressed envelope for list of radio spares and c.o.d. service.—A.D.S. Co., 261-3-5, Lichfield Rd., Aston, Birmingham, 6. 18238

LOUDSPEAKER repairs.—L. Cottenham, The leading repair specialist of the North, for your loudspeaker repairs, all types repaired, fields rewound to any resistance, field replacement bobbins, keen competitive prices and quick service.—Send to L. Cottenham, Loudspeaker Repair Factory, Whetley Lane, Bradford, Yorks; enquiries invited attention. 19579

NATIONAL RADIO SERVICE & TELEVISION Co.—Trade service, inquiries, engineering service any district; rewinds to all types transformers, armatures, motors, loudspeaker cones, speech coils fitted, British and American components and valves; enquiries invited for contract trade service; multiple transformer winding.—25, High St., St. John's Wood, N. 16752

MISCELLANEOUS
No. 74 stallow stampings; also No. 40 and others. Speedwell 2396. 19464

STEEL chassis, 1 1/2 in x 7 1/2 in x 2 in, undrilled, c.o.d. 7/9 ea.—71, Forest Rd., Quinton, B'ham. 19303

SHILLING slotmeters, checkmeters, big stock, all types.—I, Barnfield Rd., Paignton. 19303

SOUTHERN TRADE SERVICES LTD.

MAINS TRANSFORMER REPLACEMENT BOBBINS IN STOCK

- MARCONI. 262, 272, 274, 878.
- H.M.V. 440, 499, 501, 542, 905.
- BUSH. PB 61, 53, 63, 73.
- MURPHY. A3, A4, A26, A34, A46.
- PHILCO, PORTADYNE, ULTRA, FERRANTI, PARVA, LANCASTRIA, LISSEN, PYE, EVER READY, DECCA and G.E.C. 4v., 6v. & 13v.

These Bobbins are Paper Interleaved, specially impregnated, and have a Copper Static Screen.

TRADE ENQUIRIES INVITED

297/299, HIGH STREET CROYDON.
Telephone: CRO 4870.

NEW DUAL TESTOSCOPE



Ideal for high and low voltage testing; 1/30, 100/850 A.C. and D.C. Allowance made on old models.

Send for interesting leaflet (R.14) on Electrical and Radio Testing, from all Dealers or Direct.

RUNBAKEN-MANCHESTER-I

THESE ARE IN STOCK

- F-M Simplified. By Milton S. Kiver. 33s. Postage 9d.
- Elements of Radio Servicing. By Marcus and Levy. 27s. Postage 9d.
- Radars System Engineering. Ed. by L. N. Ridenour. 45s. Postage 9d.
- Radio Engineering. Volume I. By E. K. Sandeman. 45s. Postage 9d.
- Testing Radio Sets. By J. H. Reyner. 15s. Postage 6d.
- Short Wave Wireless Communication. By Ladner and Stoner. 35s. Postage 9d.
- High Vacuum Technique. By J. Yarwood. 12s. 6d. Postage 5d.
- The Mathematics of Wireless. By Ralph Stranger. 7s. 6d. Postage 4d.
- Television. By Zworykin and Merton. 42s. Postage 8d.
- Television Explained. By W. E. Miller. 3s. 6d. Postage 2d.
- The Wireless World Valve Data. 2s. Postage 2d.
- A Modern Home Built Television. 2s. 6d. Postage 2d.

We have the finest selection of British and American radio books. Complete list on application.

THE MODERN BOOK CO.

(Dept. W.3),
19-23, PRAED STREET, LONDON, W.2

THE HARTLEY-TURNER SPEAKER

though we have had a large number of con-
tatory letters on the performance of the
odel 215 we have not as yet published any
testimonials from satisfied users " mainly
cause it is rather taken for granted that a
artley-Turner customer is satisfied—at any
e so far as sound reproduction is concerned.
t the following letter seems to say what a lot
people would like to know :

" Your type 215 speaker justifies all that
you have said about it. The results at first
seemed rather mystifying owing to the
complete absence of bass or treble reson-
ances—the notes of music come out
clearly from silence without any colouration
of tone, and, too, without any of the usual
focussing which one has grown apt to take
for granted; a point which my wife
appreciates, as it no longer means that
in only one chair in the room can one hear
really clearly. The bass reproduction is a
revelation in clarity."

ne Hartley-Turner speaker tackles the problems
of high-fidelity in a very unorthodox way, and
olves them triumphantly. The results are
valuable at little more than pre-war price.

Model 215 £9. Plus Carriage.

you have not already been in touch with us,
end for illustrated leaflet.

H. A. HARTLEY CO. LTD.
52, HAMMERSMITH RD., LONDON, W.6
Riverside 7387.

COULPHONE RADIO

"The Return of Post Mail Order Service."

58 DERBY STREET, ORMSKIRK, LANCS.
Phone: Ormskirk 496. Grams: Coulphone, Ormskirk
NEW GOODS ONLY
C.W.O. or C.O.D. Post Free over 5/-

MAINS TRANSFORMERS

PRIMARIES for 200/30/50 volts. Universal 4, 7 and
6.3 v. L.T.s. 300-0-300 v. 60 mA., 23/6; 350-0-
350 v. 100 mA., 28/6; 450-0-450 v. 200 mA.,
4/ 8 s. C.T., 4 v. 4 a. C.T., 4 v. 4 a., 45/-; 450-0-
450 v. 200 mA., 6.3 v. 4 a. C.T., 6.3 v. 4 a. C.T.,
6 v. 3 a., 45/-; 450-0-450 v. 200 mA., 6.3 v. 6
a. C.T., 4 v. 2 a. C.T., 4 v. 2 a. C.T., 5 v. 3 a., 47/6;
1,250-1,000-750-0 1,000-1,250 v. 300 mA. (no
L.T.s.) 120/-; 4 or 6.3 v. 6 a. C.T. (Filament), 17/6;
Auto (Filament), 4v. to 6.3 v. 4a. (or vice versa), 13/6.

SMOOTHING CHOKES VALVES

16 H. 40 mA. 350 ohm., 5/- Over 5,000 BVA
20 H. 60 mA. 425 ohm., 6/6 and American
15 H. 90 mA. 180 ohm., 7/- valves in stock.
20 H. 100 mA. 425 ohm., 13/6
20 H. 200 mA. 150 ohm., 22/6 **EDDYSTONE 640**
30 H. 200 mA. 350 ohm., 25/- ex stock £39-10-0

OUTPUT TRANSFORMERS

Midget Power Pen., 5/6. Std. Univ., with C.T. 7/6.
Large Univs., with C.T. 12/6. Heavy Duty Univ.,
for 2, 3 and 15/2. 500 mA. 300 mA. Heavy Duty, 37/6.
SPECIAL (at author's specification) for quality
amplifier, described in April and May issues of
"The Wireless World," 67/6.

COILS, COIL PACKS, etc.

TRF. COILS, M. and L., with cct., pair 9/6. "P"
Type, 2/9 ea. Iron cored "P" Type, 3/- ea.
SUPERHET W.B., with cct., 465 kc/s., pair 11/6.
WINDING COIL PACKS, Completely aligned, 36/6.
SUPER FEEDER UNIT, 5 waveband, R.F. Stage
Magic Eye. Complete with 5 valves, £18 18s.
I.F. TRANS. Midget, 18/9 pr. Standard, 17/6 pr.
MIDGET 2-GANG CONDENSERS, .0005 L.T.,
11/6; W.Tr., 12/6. 3-gang L.T., 15/6.
KITS, 4v. Batt., 5H., 5 v. A.C.D.C. or A.C./S.H.
MURHEAD PRECISION REDUCTION DRIVES
54:1, 12/6. J.B. Full Vision, 8:1, 12/6.

SUNDRIES

LINE CORD, 3 amp. 60/50 per ft., 2 v., 2/3 yd.;
3 v., 2/6 yd. P.B. Wire, 3d. yd.
MAINS DROPPERS, 3 a. 800/5, 5/-; 2 a. 1,000/2,
4/6. **CARBON RESISTORS** (50/2 to 5 M Ω), 1 w.
6d.; 1 w., 1/-; 2 w., 1/6.

EDDYSTONE SHORT WAVE GEAR.

VIDOR RECEIVERS AND POWER PACKS.
Send 21d. stamp for new 24-page Catalogue.

PROCEEDINGS of the I.R.E., 1946 and 1947,
complete, perfect condition; offers: Box
6267 (5503

MOULDING press, 5 ton, compression, hand
operated, electrically heated, unused; £30.
—Speedwell 2396.

FOR sale, genuine Bulgain switches, type 1521,
price 2/- each in dozens, 1/9 each per
hundred. Rep. v. Box 5393. [9463

FURTHER copies of our advanced radio serv-
icing course again available.—Details,
BCM/Circuit, London, W.C.1. [19426

W. Vols. 16-25, 29-33 (inclusive), bound
and indexed, £1 each (less six or more).—
Stevenson, Pendley Manor, Tring. [19466

WALNUT radiogram cabinet manfs. sam-
ples, few only, 36"x32"x18"; stamp details.
—Walters, 501, Ha'e End Rd., E.4. [19405

FLEXIBLE P.V.C. covered 14/36 T/C wire,
7,000yds, purple, £35; also 40,000yds other
colours and conductors. —Speedwell 2396.

MOULDING press, injection, hand operated,
electrically heated 7 grammes, suitable toys
or electrical specialties; £25.—Speedwell 2396.

AMERICAN general and radio periodicals sup-
plied by postal subscription: send stamp
for list.—Herga, Ltd., 189, Waverley House,
Havelock Rd., Hastings. [19484

ACCURATE technical translations by el. engin-
eer certif. linguist French, German.—Fran:
V. Carlsbausen, A.M.I.L. (Germ.), 28, Charlton
Kings Rd., London, N.W.5. [19350

PAL RADIO offer the following: Synchron-
ized colours, sizes 1 to 2mm; 36yds. for
2/6; Amphenol valveholders, int. oct., 5/- doz.;
metal rectifiers, 160v, 40 mill, 6 for 12/6;
Sprague 0.1uf 350 metal tub., 6/- doz.; .01uf
1,000, 6/- doz.; 25uf 500, 8/- doz.; s.a.e. for
full lists.—142, Crouch Hill, N.8. Mon. 4463.

CONSTRUCT your bearings now, aluminium
tube, impregnated, 1 1/2" dia. (up to 13ft
lengths) 7d a ft. carriage paid, other sizes
in stock; standard steel racks, 6ft high, drilled
and tapped for 19in panels, list £10, 55/-,
carriage paid; send s.a.e. for component and al-
uminium list.—Fanthorpe, 6-8, Hepworth's Ar-
cade, Hull. [19447

JUNCTION electric irons, complete with stand,
switch connector and flex, again available;
very prompt deliveries; beautifully chromium-
plated; the finest electric iron of its kind in the
world; a.c. d.c., in all voltages; with rich range
of other household electrical appliances.—Distrib-
utors, Brooks & Bohm, Ltd., 90, Victoria St.,
London, S.W.1. [19023

BAKELITE switchplugs, 15x3, iron-clad
switch sockets, 15x3, shuttered surface and
sunk sockets, 15x3, all sizes of switchplugs,
sockets, plug tops, multiplex switches, lamp-
holders, battonholders, adaptors, connectors,
fuses, elements, junction boxes, fuse boxes, ceil-
ing roses, etc.; immediate delivery.—Douglas
Turner, Ltd., 13a, Edge St., London, W.8. [9257

FOR sale as a lot, back numbers "Wireless"
"World", Vols XXXI less 12, 25, XXXII less 1-
10, 11, 14, 15, 16, 18, 19, 23, XXXIII less 1, 5,
6, 7, 13, 15, 25, XXXIII less 1-12, 15, 21, 24,
XXXIV less 9, 13-7, 21, XXXV less 4, 5, 8, 9,
11, 13, 14, 16, XXXVI less 26, XXXVII less
17, 21, 24, 25, XXXVIII less 4, 6, 7, 22,
XXXIX less 8, 9, XL less 13, XLII
less 1, XLIII less 1-4, XLIV, XLV, XLVI
less 9, XLVII less 1-4. Offers.—Write, Spencer,
63, Lashford Lane, Dry Sandford, Berks. [9331

67/6; portable electric drills independent of
mains, exceptionally powerful, ex-Gov-
ernment use, Hoover or Lucas ballrace motor,
operates from lighting pant. car or lorry bat-
tery, 6 or 12v, high speed, fitted 0 to 1/4in Mur-
ray's chuck and stout leads, ideal for use with
rotary wire brush for removing rust or corrosion
or for polishing or grinding, etc.; can be
scrapped to the bench if desired for grinding or
circular saw, etc.; weight 7lb; postage and
wood packing 2/- (or c.o.d. 10d. extra).—E. A.
Mason, 153, Manchester Drive, Leigh-on-Sea.

WORK WANTED

ELECTRONIC development.

OUR laboratories and drawing office, devoted to
the design and construction of complex elec-
tronic, electrical and electro-mechanical devices.
Have some capacity available for design and de-
velopment of specialized equipment; capacity is
also available for the building of prototypes and
the small scale production of new designs; the
service is also available to manufacturers requir-
ing data and test reports on their own products.
Brecomin Laboratories, Brecomin (England)
Ltd., Gads Hill, Gillingham, Kent. Tel.
Gillingham 59095. [9266

INSTRUMENTS ear cutting capacity.—Lloyd &
Ramsey, Huntingdon St., Nottingham.

ENGINEER with 14 years' radio research ex-
perience, can take small amount of con-
sulting work.—Box 6253. [9468

WAVE winding capacity available; your
models copied or new types developed to
your specification.—Box 5044. [19087

FACTORY has technical staff and capacity
available for manufacturing scientific or
other articles in glass.—Box 4462. [18853

WE make wireless and radiogram cabinets for
home and export; immediate deliveries.
Radic, Ltd., 26, Bronesbury Rd., London
N.W.6, Maids Vae 8792. [8025

DRAWING and tracing work for radio and
electrical engineering, jig and tool and light
engineering, photoprinting; full sets of drawings
undertaken to commercial or Ministry standards.
Drawing & Tracing, Luton 456a, Ewell Rd.,
Tolworth, Surbiton, Tel. Elmbridge 7406. [7703



NOW IN STOCK NEW BAND-PASS MEDIUM WAVE COILS

iron cored fixed inductances matched to
1 per cent in aluminium cans, ready to mount
on chassis. These coils can be wired to a
single pole 3 or 4 way switch, to give a variable
band-width for high fidelity, very selective.
Colour coded, circuit supplied, also intervale
coil, but not band-pass. Price 7/6 each.
Coil switch 4/6.

STANDARD T.R.F. COIL UNIT

as used on our quality T.R.F. Receiver advertised
in "Wireless World." Miniature coils, aerial
and H.F. mounted on 16 S.W.G. aluminium
screening plate, complete with switch,
trimmers and colour code, iron cored adjustable
inductance. Completely wired, with de-
coupling condenser, trimmers. Price 30/-.

NEW BLUE PRINTS OF OUR NEW SUPER QUALITY HIGH FIDELITY H.F. UNIT

Brief Details of Circuit : 2 R.F. stages (2-EF39)
with sensitivity control, iron cored band-pass
coils for medium waves only, tuned with a
.0005 three gang condenser. H.F. transformer
coupled to a double triode (6C8), the first
triode section of which functions as an infinite
impedance detector with its well-known super
qualities for modulation. Approximately
100 per cent. The 2nd triode section of the
6C8 is used for AVC only, the output being
taken from the detector to a filter stage and
output socket, which will enable this Unit
to couple up with any type of amplifier from
which power is also taken. 6.3 heaters,
250 v. H.T., a colour coded plug is indicated
on drawing. The Unit measures 6 1/2in. front
to rear, 7in. wide, 8 1/2in. high, fitted with a
slow motion drive, dial, glass and escutcheon.
Blue Prints (2 full size Practical and 1
Theoretical) 5/- per set.

VARIABLE SELECTIVITY I.F. TRANSFORMERS

465 kc/s. giving the choice of three degrees of
selectivity: 1. High Selectivity. 2. Medium.
3. High Fidelity. Controlled by three position
switch. Iron cored, screened. The second
I.F. is centre tapped on both primary and
secondary to reduce damping. Circuit diagram
supplied. Price £1 per pair.

Still Available. Blue Prints of our 5-valve
Superhet 3-wave band circuit. Price 3/6.
Also 10-valve 6-wave bands, 12 watts output
circuit. Price 5/- per set. (2 full size Practical,
and 1 Theoretical.)

One minute's walk from Chancery Lane
Underground Station

307, HIGH HOLBORN,
LONDON W.C.1. Phone: HOLborn 4631

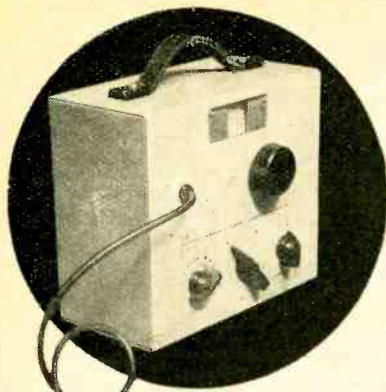

ALL-WAVE SIGNAL- GENERATORS Type 5&6

These high-quality precision instruments 200-240 volts AC Type 5, 100-250 volts AC/DC Type 6, have a coverage of 100 Kc/s to 30 Mc/s in 5 ranges. Calibrated by hand against a standard frequency accurate to 0.01%. Constructed in B.A.60 alloy and finished black and cream. Price 14 Gns. Type 5 or 6 Immediate delivery.

Illustrated leaflets on application to:

**R.R. DEVELOPMENT
LABORATORIES LTD
BARDARD ROAD • BRADFORD**

IN SPITE OF DIFFICULTIES



**SERVICE ON
LOUDSPEAKERS
IS BEING MAINTAINED.** We regret
service on PU's must
await an improvement
in Mr. Voigt's health.

VOIGT PATENTS LTD.

The Mark of
Distinction



Designed & Manufactured by:
THE LOWTHER MANUFACTURING CO.
Lowther House, St. Mark's Road,
BROMLEY, KENT.

Rev. 5225.

RADIO and amplifiers chassis to your own or our specification, top-class work and components. single orders welcomed.—A.F.E. Radio, 2, Farrance St., London, E.14. [9634]

BUSINESS AND PROPERTY

CHARING Cross Rd., Spacious ground floor and basement (about 5,000 sq. ft.) in attractive modern building; 3,000 sq. ft. on ground floor (adaptable for two units), suitable high-class showrooms for electrical, sanitary or allied trades; rent £8,000 p.a.; only first-class company entertained.—Richard Powell & Partners, 25, Coleman St., E.C.2. Tel. Mounch 5575. [9453]

BUSINESSES FOR SALE OR WANTED
RADIO manufacturing company for sale, plant, stock, assets and patent; £600; easily transferable.—Box 6407. [9636]

COMPONENT works (London), suitable live engineer, turnover £25,000; price £6,500 incl. stocks and adequate premises; genuine offer; principals only. Box 561, c/o Dawsons, 29, Craven St., W.C.2. [9455]

ELECTRICAL and mechanical contracting and radio business for sale, N.W. London; good reason for selling, low overheads, favourable lease, goodwill and equipment. £350 plus s.a.v. (approx. £500).—Box 6411. [9646]

RADIO-ELECTRICAL (Birmingham).—Skillfully managed, outstandingly successful lock-up store; sales £70,000; profits proportionately large; £10,000; book debts and s.a.v.—Harlands, 1, Rutland Rd., Bearwood, Birmingham, 17. [9510]

SOUTH LONDON radio, television, records, electrical sales, etc., for sale; beautifully fitted large double-fronted shop; excl. agencies; rent £300 p.a. exc.; about 20 years' lease; now under management; price £3,500. s.a.v.—Full pars., Cavey & Co., 306 Queens Rd., S.E.14. [9449]

THE proprietor of British Patent No. 531963, entitled "Device for producing vibrato in sound amplifying systems and the like," offers same for licence or otherwise to ensure practical working in Great Britain.—Inquiries to Singer, Ehler, & Stern, 25, East Jackson, Chicago 4, Illinois, U.S.A. [9449]

SITUATIONS VACANT

Vacancies advertised are restricted to persons or employments excepted from the provisions of the Control of Engagement Order, 1947.

AMMATURE winder and stator winder for small firm with good contacts; exceptionally good prospects for young man with ambition.—Box 5551. [9285]

SERVICE engineer required, sound practical knowledge all types domestic receivers, experience television an advantage, able to drive. N.W. London.—Box 6396. [9614]

TELEVISION repairers required on servicing receivers; previous experience in this class of work essential; West London.—Appy. stating age, details of experience and salary required, to Box 6256. [9474]

BERY'S SHORT WAVE, Ltd., have a vacancy for counter sales assistant; applicants should have good technical knowledge and previous business experience.—Applications in writing to 25, High Holborn, W.C.1. [9448]

BATTERY charger designer/engineer required on development work for production and special types, both valve and metal.—Appy Personnel Manager, Edison Swan Electrical Co., Ltd., Ponders End, Enfield, Middx. [9460]

DESIGNER-DRAUGHTSMAN required for factory, Northern area; must be conversant with Radar and radio equipment construction.—Reply, stating age, full details of experience, training and salary required to Box 5548. [9279]

DRAUGHTSMEN required for jig and tool drawing office, must be familiar with electronic equipment construction, Manchester area.—Appy. giving full particulars of experience, qualifications and salary required to Box 5547. [9472]

ASSISTANT electronic engineer required for radar laboratory, mathematical qualifications and some previous experience necessary, age 20 to 30, salary £350 to £450 per annum.—Write Box N5868, A.K. Adv., 212a, Shaftesbury Av., W.C.2. [9530]

LLOUDSPEAKER engineers required (additional to present staff) to carry out research and development work.—Apply in writing, giving full details of experience, education, age, salary required. Goodmans Industries, Ltd., Lancelotti Rd., Wembley, Middx. [9232]

RADIO senior assembly foreman required, Manchester area, must be capable of controlling male and female labour, experienced in assembly belt layout, and familiar with A.T.D. requirements.—Appy. stating age, experience and salary required, to Box 6254. [9472]

REQUIRED, service manager capable of taking complete charge of service dept., and building up an organisation; this is a responsible position; salary in secondary consideration; applicant must have had previous experience in a similar post; write, giving full details.—Box 5936. [9440]

DEVELOPMENT engineers required by radio manufacturers in Essex for work on centimetric waves; candidates should possess a University degree preferably with telecommunication as a subject; age 25-35; salary according to age and experience.—Apply to Box 5546, quoting Ref. 91. [9276]

REQUIRED, machine shop superintendent, by radar and radio company, Manchester area, must be capable of supervising the production of components for assembly lines; knowledge of machine, press and fitting operations essential.—Apply, giving full particulars of experience and salary, etc., to Box 6257. [9475]

A NEW TELERADIO CHASSIS

Model A70

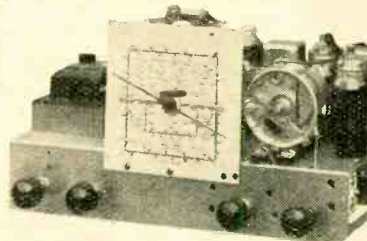

6-Valve A/C MAINS R/G CHASSIS,
15-50, 200-600, 540-2,000 Metres with
TUNING INDICATOR, TONE
CONTROL.

14 Gns. plus P. Tax.

Also available as tuning unit feeding push-pull amplifier. Blueprints can be supplied for home construction if desired.

Export enquiries invited

Send 2½d. stamp for full illustrated lists to

THE TELERADIO CO.,
157, FORE STREET, LONDON, N.18

Tot.: 3386

PHOTO-ELECTRIC CELLS

for

Talking Picture Apparatus.

Catalogue now available

RADIO-ELECTRONICS LTD.,
St. George's Works, South Norwood,
London, S.E. 25.

100 kcs.
QUARTZ
CRYSTAL
UNIT
Type
Q5/100



for Secondary Frequency Standards

★ Accuracy better than 0.01%. ★ New angles of cut give a temperature coefficient of 2 parts in a million per degree Centigrade temperature change. ★ Vitreous silver electrodes fired direct on to the faces of the crystal itself, giving permanence of calibration. ★ Simple single valve circuit gives strong harmonics at 100 kcs. intervals up to 20 Mcs. ★ Octal based mount of compact dimensions. PRICE 45/- Post Free

Full details of the Q5/100, including circuit are contained in our leaflet Q1. Send stamp to-day for your copy

THE QUARTZ CRYSTAL Co., Ltd.
63-71 Kingston Road,
NEW MALDEN, SURREY
Telephone : MALden 0334

EX-R.A.F. COMMUNICATIONS RECEIVER R.1224.A. A 5 valve battery superhet covering 1.0-10.0 mcs. in three switchable bands. Has Muirhead slow motion dial, aerial trimmer, sensitivity control, etc., etc. Circuit employs R.F. stage. Power supply 2 v. L.T., 9 v. G.B., 120 v. H.T. Complete with valves as follows: 2 type V.P. 23 & 1 each FC2A, HL2 & PM2A. Circuit diagram supplied. Cabinet size 15in. x 9 1/2in. x 8 1/2in. ALL BRAND NEW IN ORIGINAL PACKING. ONLY 99/6. (Carriage, etc., 7/6).

SHORT WAVE CONVERTERS. EX-R.A.F. RF Units. Contain 3-6 volt SP 41's, HF, Mixer, and Oscillator. 7 mcs. I.F. output. 5 pre set frequencies. Easily convertible to tunable converters by replacing ceramic switch with 3 ganging type 15 pf condensers. Type 24 for 15-30 mcs. Type 25 for 30-45 mcs. Slightly used but in excellent order. ONLY 25/-. (Carriage, etc., 2/6.)

2 VOLT BATTERY SUPERSEDERS. A Vibrator Power Unit operating from an input of 2 volts and giving 90 v. & 180 v. at 35 mills, 1.4 v. LT. and GB. Fully smoothed, ready for use, and easily adaptable for any purpose. Consumption approx. 1/4 amp. Complete in steel case with two 2 volt accumulators, and instruction book giving full circuit details. ONLY 90/-. (Carriage 5/-). Or we have a few of the VIBRATOR UNITS ONLY without accumulators and case, but with instruction book, at 60/- (carriage 2/-). Spare vibrator 15/-. A superb job, originally made for the Canadian Army.

C.W.O. Please. S.A.E. for lists.

U.E.I. THE RADIO CORNER
Corp.

138, GRAY'S INN ROAD, LONDON, W.C.1

Phone: TERminus 7937.

Open until 1 p.m. Saturdays, we are 2 mins. from High Holborn, 5 mins. from King's Cross.

THE P-A-GRAM



15W. AMPLIFIER PLAYING DESK, 10in. SPEAKER.

Complete in two leatherette cases. For concerts, dances, etc.—perfect.

PRICE (ex Works) £37.

THE OLD FAVOURITES AC/18 RANGE have an extra stage incorporated. SIX POSITION BASS BOOST SWITCH WITH TREBLE VARIABLE CONTROL, OPERATED WITHOUT APPRECIABLE DROP IN APPARENT VOLUME LEVEL.

The 1948 Range described in new list A/48
AC/19 14 gns. AC/19HG 16 gns.
AC/27 18 gns. AC/30 20 gns.
Also W.W. Quality Amplifiers included in an entirely new range of 15 models.

Our Transformer Division is issuing a new catalogue (3d.) embracing revised range of power and output transformers for all circuits.

GENERAL LAMINATION PRODUCTS LTD.,
294, Broadway, Bexleyheath, Kent
(Bexleyheath 3021)

PLANNING engineers required by radar and electronic equipment company, Manchester area, must have general engineering apprenticeship and be capable of developing and planning all machine shop, fitting and assembly operations.—Apply, stating age, experience and salary required, to Box 6260. [9478]

TRANSFORMER department superintendent required by radar and radio equipment company, North Manchester area, must be capable of controlling labour, be conversant with all operations of coil winding, impregnation and assembly.—Reply, giving details of age, experience and salary required, to Box 6258. [9476]

RADIO assembly.—Large manufacturer in the South requires a superintendent and several foremen, suitable applicants must have thorough experience of this class of work and must be capable of controlling large female labour force.—State details of experience, age and salary required to Box 6373. [9593]

RESearch department of instrument making firm in N.E. London requires graduate in physics or engineering, with good communications experience, particularly in acoustics and electronics, including the design of amplifiers for output up to 2 kw.—Write giving age, experience and salary required, to Box 6264. [9496]

ASSISTANT physicist, preferably with some electronic knowledge, required for work on waveguide systems: mathematical and academic qualifications essential, practical experience and mechanical ability an advantage, age 20 to 30; salary £350 to £450 per annum.—Write Box N5864, A.K. Advy., 212a, Shaftesbury Av., W.C.2

SUPERINTENDENT required to take charge of radar and radio assembly dept. electronic equipment company, Manchester area, must be familiar with A.I. requirements and capable of controlling labour on track and bench assembly.—Reply, giving full particulars of age, experience, qualifications and salary required, to Box 6259. [9477]

DRAGHTSMAN with some experience in light electrical engineering is required for work on prototype equipment in connection with television transmitters.—Apply by letter only to the Director, Research Laboratories of the General Electric Co., Ltd., North Wembley, Middx., stating age, experience and academic qualifications. [9605]

ENGINEERS required for employment on development of Radar, communication and electronic equipment; applicants must possess a degree in engineering or its equivalent; salary £400 to £500 per annum according to qualifications.—Reply, stating age, experience, training and qualifications, etc., to Cossor Radar, Ltd., Wien Mill, Chadderton, Nr. Oldham, Lancs.

RADIO manufacturers, West London district, have vacancies for senior development engineers and laboratory assistants for work on design and development of telecommunication equipment and broadcast receivers; for the senior posts, at least 5 years' practical experience in this class of work is essential.—Write, stating age, qualifications, experience and salary required, to Box 6266. [9504]

PHILIPS ELECTRICAL Ltd., require engineers in the Birmingham and Manchester area to deal with public address equipment and installations; a good standard of technical knowledge and commercial experience in Public address or other allied trade is essential; successful applicants must be prepared to reside in London for several months for preliminary training, and possession of a car is essential; write, giving full details as to age, previous experience and salary required, to Box 5522. [9213]

E.M.I. ENGINEERING DEVELOPMENT, Hayes, Middlesex, invite applications from junior and intermediate engineers, age 25 to 30, with engineering degree or the equivalent, and practical design experience; specific vacancies on radar development include the following work: (a) design of 30-100 Mc I.F. amplifiers, (b) transformers for higher frequency power supply, (c) special problems on radar presentation; there are several other interesting vacancies for physicists and engineers; inclusive salary £400 to £550, according to age and qualifications.—Write, giving full details and interests, to Personnel Dept.

APPPLICATIONS are invited for the post of Assistant engineer in charge of a broadcasting station at Recife, Brazil. This appointment is for a period of three years in the first instance with a possibility of promotion or renewal at the end of this period; salary will be within the range £480 to £600 p.a., according to qualifications and experience, and new furnished apartments will be provided for a single man; applicants must possess good technical qualifications and have experience in the design and operation of communication transmitters, superhet receivers and high speed W.T. systems; a knowledge of carrier current technique advantageous; age not over 35, secondary school education; attractive salary plus generous allowance in local currency.—Write, giving age and full particulars of qualifications and experience, quoting Department F.96, to Box 1075 at 191, Gresham House, E.C.2. [9525]

You're SURE to get it at

STERN'S

ESTABLISHED 25 YEARS

Electrolytics. Dubilier, 8 mfd. 500 v. 4/- (Canned, 4/6); 8-8 mfd. 500 v. 6/6; 16 mfd. 500 v. 6/6; 8-16 mfd. 500 v. 8/6; T.M.C. 8-16 mfd. 450 v. 7/6; 32 mfd. 450 v. 5/9; 16-16 mfd. 450 v. 7/9; 4 mfd. 450 v. 3/6; 25 mfd., 25 v. 2/-.

I.F. Transf. 465 kc/s. Wearite Migdet Iron-core, 21/- pair. Weymouth Perm. Tuned, 18/9 pr. Service Cap. Tuned, 12/6 pr. (110 kc/s., 15/- pr.) Mica. Surtopus New 465 kc/s. Iron Core, 13/6 pr.

Coils, T.R.F. Matched pair M. & L., 6/9 pr. Weymouth T.R.F. Matched pair, M. & L., 9/6. 8/Het Matched pair, S.M. & L., 11/6 and 8/9 pr. Wearite "P" Coils—complete range A, H.F., Osc., A.F. and B.F.O., 3/- each.

L.F. Chokes. 20 Hy, 200 ohms, 60 ma. 6/6; 20 Hy., 350 ohm, 100 ma., 15/9; 50 Hy., 900 ohm, 60 ma., 13/6.

Tuning Cond. (Twin Gang). .0005 mfd., 9/6 (with Trim.), 12/6. .00075 mfd. (with Tr.), 10/6. Migdet .001 mfd., 5/-. Migdet .00035 mfd., size 1 1/2 in. x 1 1/2 in. x 2 in., 12/6.

Resistances. Most values available in 1, 1/2, 1, 3, 5, 10 and 20 watt, from 4d. each.

Condensers. Tubular. .1, .01, .5, .05 mfd., etc., at 9d. each.

Potentiometers. Centrab. 5k. 10k, 25k, 50k, 100k, 1/2, 1 and 2 meg., less Switch, 6/3 with Switch, 6/-. Migdet with Switch, 1 and 1 meg., 6/-.

M Coil Speakers. Page bin. P.M., 15/-. Rolar bin. P.M., 21/6. (Energ. 1,000 ohm with Tr., 29/6). Rola bin. P.M., 24/-. with Tr., 30/-. (Energ. 1,500 ohm., 31/6 or 2,000 ohm. with Tr., 36/6). Goodmans 10in. P.M., 35/-. Rola 10in. P.M., 32/6 or Energ., 1,500 ohm. with Tr., 36/6.

Output Transf. Franklin Migdet Power Pentode. 5.9. Multi 12 Ratio 4/5 watts C.T., 9/-. Multi Ratio Heavy Duty Types C.T., 10 watt 21/-. 20 watt 30/-. Filament Transf. Input 200-230-250 v. Output 5 v. 4 a. and 6.3 v. 4 a. (both tapped 4 v.), 27/6. Input 200-250 v., out. 6.3 v. (C.T.) 4 a., 18/6.

Class A P Pull Input Transf. 20 Hy. 5 m.a., 2.5-1 each half, C.T. Pri. and Sec., 14/-. Selenium Rect. 6 v. 1 1/2 amp., 7/6, 12 v. 1 a. 12/6, 12 v. 3 a. 24/-. 12 v. 6 a. 37/6, also 180 v. 100 ma. 5/9, 240 v. 60 ma. 5/9, 240 v. 100 ma. 7/6.

Meter Rect. 0-5 m.a. and 0-10 m.a., 5/9. Westinghouse 0-1 m.a. 10/6.

Auto. Transf. Input 200-230-250 v. Output tapped 4 v., 8 v., 15 v., and 24 v. at 3 amp., 27/6.

M.Transf. 250-0-250 v., 80 m.a., 6/3 a. (tapped 4 v.), 5 v. 24 a. (tapped 4 v.), 34/-. 350-0-350 v., 80 m.a., 6.3 v. 4 a., 5 v. 3 a., 30/-. (or at 150 m.a., both tapped 4 v.), 38/6. 400-0-400 v., 150 m.a., 5 v. 24 a., 6.3 v. (C.T.), 3 a., 6.3 v. (C.T.), 3 a., 47/6.

Ex-Govt. Ultra Migdet O'put Transf. 32-1, and P/Pull Intervale Transf., 2.0-1 each half, both 1 in. x 1 in. x 1 in., 9/- each. Ultra P/Pull Intervale, 2.5-1 each half, and O'Put Transf. 60-1, both 1 1/2 in. x 1 1/2 in. x 1 1/2 in. 3/- each. L.F. Chokes, 5 Hy. 100 ohm, 150 m.a., 6/9. 15 Hy., 270 ohm, 170 m.a., 12/6. Split-Stator Transm. Cond., 150 Pf. each half, 4/9. Throat Mike, 3/6. Tannoy Transverse Carbon Mike Inset. 3/- Moving Iron Mike Inset. 2/3.

★ Send 2d. stamp for Stock List. When ordering please cover packing and postage.

STERN RADIO LTD.
115, FLEET STREET, E.C.4.
Telephone: CENTral 5814 and 2280.

WARD ROTARY CONVERTERS

For Radio, Neon Signs, Television, Fluorescent Lighting, X-ray, Cinema Equipment and numerous other applications.

We also manufacture:—
Petrol Electric Generating Plants, H.T. Generators, D.C. Motors, etc., up to 25 K.V.A.

CHAS. F. WARD
LORDSCROFT WORKS, HAVERHILL, SUFFOLK
Telephone: Haverhill 253 & 4.

TEST GEAR RECEIVERS AND DATA

BC.221 Frequency Standard. U.S. manufacture. Accuracy 0.05%. Frequency range 125 Kc.—20Mc/s. Crystal controlled and temperature compensated. Complete with instruction book, £25. Carriage 10/- Packing case 10/- extra returnable.

BC.348. A much coveted receiver with a frequency range of 200-500 Kc. and 1.5-18 Mc/s. Six position switch brings separate frequency calibrated dial into position and superfine Vernier tuning unit gives 90 turns of tuning for each band—two stages of R.F.—three stages of I.F.—crystal filter—voltage stabiliser—automatic noise compensation—constant sensitivity on all bands—phone and speaker output—all standard 6.3 volt valves. **PRICE £28 10s.** plus 10/- carriage, plus 10/- packing case returnable.

R.1155. Aerial tested—perfect condition in transit case. **PRICE £12 10s.** plus 10/- carriage.

R.208. The Army precision receiver, covers 10-80 Mc/s. Built-in power pack for A.C. mains or 6-volt battery inputs—built-in speaker—phone jacks—Muirhead slow motion drive—A.F. gain—R.F.O. frequency control—R.F. gain—test panel on front—complete with all valves and in grey metal case. **PRICE £12 10s.** carriage 30/- extra. £1 will be refunded on return of packing case.

DATA BOOKS. Copied from official publications, giving circuit diagrams, component values and useful notes: **BC.342—BC.348—BC.312—BC.221—R.208—R.103A—R.107—M.C.R.1—R.1155—W.8.22—R.T.18—W.8.19—R.116A—all at 2/3d each, also Walkie-Talkie 58, 3/6—Demobbed Valves—e.g. Service Valves and Commercial equivalents, 2/6. WINTER LIST free on application with stamp.**

BULL'S EX-GOVERNMENT DEPOT

42-46 WINDMILL HILL, RUISLIP MANOR, MIDDLESEX.
Open Sat. till 5 p.m. Weekdays till 6 p.m.

LONDEX for RELAYS

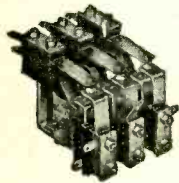

for A.C. and D.C.
2 VA Coil consumption from 2 to 600 volts and tested to 2000 volts, Aerial Changeover Relays, Mercury Relays, Measuring Relays and Time Delay Relays.

Midget Relay ML/C Ask for leaflet RE/WW

LONDEX LTD SYD. 6258-9
MANUFACTURERS OF RELAYS
207 ANERLEY ROAD LONDON S.E.20

"WEYRAD" PERMEABILITY TUNERS

SUPERHET OR T.R.F. AS EXHIBITED AT **RADIOLYMPIA**

SEND FOR DETAILS

WEYMOUTH RADIO MFG. CO., LTD.
CRESCENT WORKS, WEYMOUTH

ENGINEERS required for employment on mechanical design of Radar communication and electronic equipment, applicants must possess a degree in engineering or its equivalent, and be capable of producing designs suitable for small and mass scale production.—Write, stating age, details of experience, training and qualifications, etc., to Cosor Radar, Ltd., Wren Mill, Chadderton, Nr. Oldham, Lancs. (9280)

EM.I. Institutes (associated with H.M.V., Marconiphone, etc.), require a lecturer in radio communications: science degree (or equivalent) and good practical outlook essential; commencing salary about £300, according to age, qualifications and experience; cost of living bonus 29/6 extra per week, in addition to superannuation benefits.—Apply, giving fullest possible particulars, to Principal, E.M.I. Institutes, 43, Grove Park Rd., London, W.4. [9515]

(A) A senior radio development engineer is required by the South-Western Division of a leading radio company. Candidates should have had practical experience in radar work and be capable of controlling sections developing radar and atomic energy electronic equipment; commencing salary will be £600 upwards according to qualifications and experience, and housing accommodation is likely to be made available in the near future to the person appointed; full details should be submitted immediately.

(B) The Company is also appointing a junior development engineer (inter B.Sc. or equivalent) candidates for this post must have had practical experience in radar and communications equipment design; the commencing salary will be £350-£400, with every prospect and facility for advancement; full details of qualifications and previous experience to be sent in writing. Box 5542. [9263]

THE MULLARD ELECTRONIC RESEARCH LABORATORY invites applications for the following posts: (1) A senior scientist to lead a group working on ultra high radio frequency circuits in close association with valve laboratory and on centimeter wave projects; he should have a good honours degree in physics or electrical engineering or mathematics, at least five years' experience in the UHF field, and be capable of both experimental and theoretical treatment of problems in this field. It is expected that the age of the successful candidate will be between 27 and 35 years and his salary between £650 and £1,000 a year, according to experience and ability. (2) Scientists for both the group mentioned above and other groups working on super-sonics, electronic measurement and control, television and radio component design. They should have similar academic qualifications to the senior man and preferably some previous research work. It is expected that the successful candidates will be between 20 and 30 years and their salaries between £350 and £700 a year, according to qualifications.—Applications should be made to the Manager, Mullard Research Laboratories, Salford, Surrey.

B.C. (invites applications from men (British) for the posts of draughtsman (Class 1) and (Class 2) in the drawing office of the research department. Applicants should be experienced draughtsmen with a good knowledge of radio communication equipment and light mechanical designs; experience in the design of radio frequency, television or recording apparatus would be an advantage. Applicants must be capable of preparing first model or manufacturing drawings from information supplied in sketches or from verbal instructions, knowledge and ability to select components is essential for this work; the successful applicants will be expected to work in close liaison with the model shop, and be capable of supervising the work of any drawing office staff working under them; they will be based initially at Basing, London, but later will probably be transferred to Kingswood, Surrey. The salaries are in grades, for draughtsmen (Class 1) rising by annual increments of £25 to a maximum of £580 per annum, and for draughtsmen (Class 2) rising by annual increments of £20 to a maximum of £475 per annum.—Applications, stating age, qualifications and experience, should reach the Engineering Establishment Office, Broadcasting House, London, W.1, within 14 days of the appearance of this advertisement. Please quote R.D.1. [9467]

SITUATIONS WANTED

EXPD. priv. sec. (sht.-typ.) many years' exp. radio and elec. eng. trades, London district.—Box 6440. [9670]

EX-R.A.F. wireless mech. 23, good theoretical knowledge, radio circuits, seeks practical experience in radio servicing.—Box 6371.

R.A.F. Sgt. wireless-fitter, 29 years old, C. & G. I and II, passed Apt. req. test, progressive position in Essex, radio or electronics; previous civilian radio experience.—Box 6376.

SERVICE eng., 30, seeks position in London S area, preferably with opp. to extend ltd. television experience, 8 years' civilian experience plus 6 years in R.A.F. as wireless mech.—Box 6391.

RADIO lab. technician, 12 years' experience R design, construction, wiring, testing of production and experimental apparatus, seeks part-time week-end work London-Guildford area. Preferably at home.—Box 6276. [9534]

EX-SERVICE wireless mechanic, present employment, seeks position in construction test gear, eight years' general clerk, pre-war, seeks progressive situation where both technical and commercial experience could be usefully employed; willing to study; not averse to travelling.—Box 6409. [9642]

HILL & CHURCHILL LTD.

BOOKSELLERS

SWANAGE, DORSET

Available from Stock:

- Ghirardi, "Radio Troubleshooters Handbook" ... 37/6
- Ghirardi, "Radio Physics Course" ... 37/6
- Ghirardi, "Modern Radio Servicing" ... 37/6
- Hall, "Radar Aids to Navigation" ... 30/-
- Wellman, "Elementary Radio Servicing" ... 21/-
- Nilson & Hornung, "Practical Radio Communication" ... 39/-
- Skilling, "Fundamentals of Electric Waves" ... 18/-
- Rider, "Inside the Vacuum Tube" ... 30/-

Postage extra.

CATALOGUE ON APPLICATION

EDDYSTONE

'504' '640' '680'
and
Full range of S.W. components.

Also
Valves, condensers, transformers, resistances, etc.

All C.O.D. orders promptly executed.
52 page catalogue 1/- post free.

B.T.S.

THE Radio firm of the South.
63, London Road, Brighton, 1, Sussex.
Phone Brighton 1555.

RANSOM FOR RADIO VALVES

OFFER GOVERNMENT SURPLUS STOCK.
SPEAKERS—VO/T., P.M. 5in. Rola 12/6, 6in. Trevox 16/-, 8in. Blue 16/8, 12in. 20 watt Vitavox 28. With transformer, 5in. Goodmans 22/-
YAXLEY SWITCHES—4 P. 2 W. 2/-, 8 P. 4 W. 3/6, 6 P. 2 W. 2/6
VOLUME CONTROLS—Less switch, 3,000, 50,000, 75,000 ohm at 1/8, 25,000 ohm 1/-, 50,000 ohm wire-wound 2/3. Double Pole switched 5,000, 125,000 ohm 3/-
VALVE HOLDERS—Doz. PAX 4 and 5 pin B.V.A. 3/-, U.S.A. Octal 5/-, Amphenol Mazda Octal 5/-
CONDENSERS—Doz. Tubular (0.01 m. 1,000 v.) (0.02 m. 300 v.) (0.2 m. 750 v.) 6/6, (0.05 m. 1,000 v.) (1 m. 500 v.) (25 m. 500 v.) 7/6, 1 mfd. 350 v. 17/-, 2 mfd. 150 v. 20/-, 4 mfd. 450 v. 28/-, 8 mfd. 350 v. 27/-, 50 mfd. 12 v. 15/-, CAN OIL, 2 mfd. 350 v. 18/-, 4 mfd. 600 v. 48/-
METERS—0-15 v., 0-250 v. Combined 19/6, Record 0-5 ohms 50/-, Ediswan 0-150 v., 0-150 m/a. 50/-
SUNDRY—Sleeving, 1 m.m., green 1/- doz. yds. Cabinets, Oak, Midget 25/-, Toggle Switches, 8 P.S.T. 1/7. Radio screwdrivers 6d.
NOT EX-GOV'T.—Condensers Hunts, 16x16 mfd. 450 v. 11/-, 16x24 mfd. 350 v. 9/6, T.M.C. 16x8 mfd. 450 v. 6/3, Plessey 52 mfd. 350 v., small 5/9, T.C.C. 8 mfd. 150 v. 3/-, Electric ketles 39/6, 10in. Speaker Cabinets 9/6.
VALVES—10,000 stocked, most types available at B.O.T. prices. Retailers not supplied. Send for Valves Available List, printed monthly, also Component List. Enclose stamp for replies.
Terms: C.O.D. or C.O.

H. RANSOM,
34, BOND STREET, BRIGHTON. Phone Brighton 5603.

Are you missing the GREATEST BARGAINS in Ex M.O.S. Stock?



New and unused in sealed tropicalised packing. Rotary Transformers Type 79. Input 220 volts. Output 300 volts, 260 volts, plus 150 volts, 6 M.A. 16/- POST FREE

ALSO Ex R.A.F. New and Unused in Sealed Cartons. Motor Generator, Gear Box, Blower, etc. Input 9 volts. Output 450 volts, 500 mills. Motor Revs. approx. 1,500. Gear box approx. 12 R.P.M. plus 1 R.P.M. May be made into an efficient A.C. Motor by removal of D.C. Brushes and putting field in series with H.T. Brushes and Mains. Post free 30/-

Send stamped addressed envelope for illustrated lists. WIRELESS INSTRUMENTS (Leeds) LTD. 54-56, THE HEADROW, LEEDS, 1

TUITION THE British National Radio School OFFERS you a career. WRITE to-day for free booklet describing our wide range of training courses in radio, Radar, telecommunications, principles, mathematics, physics, and mechanics; correspondence and day classes for the new series of C. & G. examinations; we specialise in turning "operators" into "engineers", and for this purpose our "Four Year Plan" (leading to A.M.I.E.E. and A.M.Brit. I.R.E. with 9 C. & G. Certificates as interim rewards) is unsurpassed. Our guarantee has no strings attached. Studies Director, B.Sc., A.M.I.E.E., M.Brit. I.R.E., 66. Addiscombe Rd., Croydon, Surrey. 19311 COMPLETE correspondence course covering amateur and C. & G. 1 exams, consisting of 12 lessons, send for particulars.—Everyman's Correspondence College, 72, St. Stephens House, Westminster, S.W.1. 19839 RADIATOR training.—P.M.G. exams. and I.R.E. Diploma; prospectus free.—Technical College, Hull. 10511 POSTAL courses of instruction for amateur radio transmitting licence, P.M.G. Certificates in wireless telegraphy, Ministry of Civil Aviation Certificate, radio engineering and television; also instruction at school.—Apply British School of Telephony, Ltd., 179, Capham Rd., London, S.W.9 (Estd. 40 years).

THE RADIO ENGINEERING SCHOOL, air service training, Hamble, Southampton, offers full-time residential training for radio engineers seeking responsible positions in industry or civil aviation; students are coached for C and G telecommunications and Brit. I.R.E. exams as preferred; tuition also available to M.C.A. requirements in radio and radar.—For full details apply to the Commandant. 19265

AGENCIES LIVE sales engineer, about to tour India in connection with a special electrical device, would welcome any other lines or suitable agencies; bankers' reference or bond could be given.—Box 6269. 19506

FINANCIAL PARTNERSHIP PARTNER required to expand radio television business S.W. London; good class area; min. investment £1,000.—Box 6403. 19625

TECHNICAL TRAINING A.M.I.E.E., City and Guilds, etc., on "No Pass No Fee" terms; over 95% successes; for full details of modern courses in all branches of electrical technology send for our 112-page handbook, free and post free.—B.I.E.T. (Dept. 388A) 17, Stratford Place, London, W.1. 19620

EBOOKS, INSTRUCTIONS, ETC. R.S.G.B. technical publications.—The following are of special interest to transmitting amateurs and short-wave enthusiasts:—"MICROWAVE Technique"—An up-to-date treatise on a subject of vital interest, 68 pages, 2/3 post free. "SERVICE Valve Equivalents."—Lists commercial equivalents of many hundreds of Service and CV types. 28 pages, 1/-, post free. "THE Transmitting Licence."—How to obtain an amateur licence. 32 pages, 1/-, post free. "RADIO Handbook Supplement", 4th edition. Radio mathematics, D.F.E. C.R. tubes, etc., etc. 168 pages, 2/9 post free. "R.S.G.B. Bulletin"—Monthly pub. of the R.S.G.B. 1/6 post free. (Free to members.) RADIO Society of Great Britain, 28, Little Russell St., London, W.C.1. 19225

WEBB'S radio map of the world locates any station heard, size 40x30in, 4/6, post 6d., on linen, 10/6, post free.—Webb's Radio, 1-4, Soho St., W.1. Gerrard 2089. 19497

TRANSFORMERS & COILS TO SPECIFICATION. MANUFACTURED OR REWOUND. Filter Coils a Speciality.

JOHN FACTOR LTD. 9-11 EAST STREET, TORQUAY, DEVON. Phone: Torquay 2162

VIBRO-ARC ELECTRIC METAL ENGRAVING TOOL. Engraves, etches, marks, writes... on BRASS, COPPER, SILVER, NICKEL, ALUMINIUM, CHROMIUM. Operates from 4 or 6 volt Accumulator or A.C. Transformer. Order C.O.D. or C.W.O. Sole Distributors: BULLS (W) 246 High St., Harlesden N.W.M. 15/-

RADIO BULLS VALVES 246 HIGH ST. HARLESDEN, N.W.M.

BRIMAR.—R2, 5Y3, 5U4, 80, 5Z3, 5Z1, 6X5, 5V4, 1D5, 2524, 1D6, 0Z4, 3524, 15D2, 9D2, 8D2, 10D1, 11D5, 11D3, 7D5, 6A8, 6K8, 6U7, 6K7, 6J7, 616, 6C5, 625, 607, 6K7, 6R6, 6L6, 68N7, 618, 6V6, 68F7, 6L5, 6C8, 68T, 6J7, 25A6, 129Q7, 128K7, 128K7, 128K7, 129Q7, 128K, 128L. C/S/SOR.—45U, 47HA, 41TH, 41MP, MVSPEN, MSPEN, 5- and 7-pin, DD14, D1T, 41MT1, 41M11, 41MP, PT41, 2P, 202STH, 13VP4, 13SP4, 2101HF, 2101DT, 215P, 220OT, 240QP, 210LF, 4TSP, 4TSA, 202VPB, 202VP, 130, 807. MARCONI/CSRAM.—U10, U14, U16, U17, U18/20, U50, U32, U31, U74, U76, VMP4G, MS4B, MSF4, 5- and 7-pin, D41, MH4D, M14, MCT4, 5- and 7-pin, KT41, DA80, MS4B, H30, X65, KTW63, KTW63, KTW61, H68, L63, H103, K544, KT86, KT91, Y63, KT71, XG1M, V774, K776, KT33C, W21, Z21, HD24, 1P2, KT2, P2, QP21, Z22, Z62, Z66, G1TC, GU50, MAZDA.—U1U6, V914, ACC, AC6en, 5- and 7-pin, HL41DD, SP11, V741, P41, DD41, HL42E, TH2821, Pen3520, VP133, Pen383, Pen453DD, HL133DD, HL121D, QP230, TP22, TP25, TP26, Pen25, QP25, DD207, HL23, HL23DD, VP23, D1, CC135, DAF91, Pen3520, DP91, DK91, EA50, EB34, EC33, EC33C, DC33, EC32, EC33, EC33B, EC135, EF9, EF36, EF39, EK32, EL2, EL22, EL33, EL35, EL37. MULLARD.—DW2, 10W4350, FV4500, AZ1, AZ31, EL38, EM1, EM4, EM34, 1V4350, UR3C, TH4B, VP4, P44, SP4, 5- and 7-pin, 2D4A, 354V, TT4, PM24M, Pen4DD, D024, D026, D030, Pen428, TH21C, TH30C, FC13, VP13C, SP13C, 2D13C, HL13C, VP13A, HL13, SP13, Pen36C, CL4, VP13, SP2, PM2A, PM2M, FC2, PC2A, QP22B, DF33, KK32, KF35, KB32, KL35, EB12, EC121, VCH21, HV2, HV2A, EF50, EF6, EL50, AC6pen, CL33, UY11, EF22. PHILIPS.—1821, CY31, C1C, C1, CY1. TUNGSRAM.—LD210, LP220, L14, APP4C, APP4G, APV4, E24, 2A6, 2A7, 2B7, 6A7, 6B8, 6C6, 6D6, VP13K, PP35, HL13, 6AC7, 12C8, 25Y3G, HL14106, HP1018, HP105. AMERICAN.—024, 1A4, 1A5, 1B5, 1D7, 1X55, 1JG6, 185, 1T5, 1V, 2A5, 2A7, 2H7, 3A5, 3Q5, 5U4, 5V4, 5Y3, 5Z3, 5Z4, 6A3, 6A7, 6A8, 6AB7, 6AC7, 6AE5, 6AE6, 6B7, 6B8, 6C4, 6C5, 6C6, 6C8, 6D5, 6D6, 6D8, 6EG, 6P6, 6P7, 6R6, 6G6, 6H6, 6J5, 6J7, 6K5, 6K6, 6K7, 6K8, 6L5, 6L6, 6L7, 6Q7, 6R7, 68A7, 68F7, 68G7, 68H7, 68J7, 68K7, 68L7, 68T7, 68U7, 68V7, 68W7, 68X7, 68Y, 68Z, 7A7, 717, 10, 12A5, 12A6, 12A7, 12B5, 12F5, 12K7, 12K8, 12Q7, 129A7, 128F5, 128K7, 128L7, 1297, 1407, 1427, 14A7, 14B7, 14C7, 14D7, 14E7, 15, 17, 18, 20, 22, 2524, 26, 27, 32, 34, 35A5, 35L6, 35Z4, 35Z5, 37, 38, 42, 43, 46, 48, 49, 50, 53, 55, 56, 59, 71A, 76, 77, 78, 79, 80, 83, 84, 89, 95A, 955, 956, 9001, 9002, 9003, 9004, 9006, 9006, and 101 more types. Order C.O.D. above listed or equivalents (subject to stock). Please enquire for any valve you require. Old and new types arriving daily. Old stock at pre-reduced and pre-Budget prices. Just in: MVSPEN, 4THA, D176, 43-U, X22, X24, GDT4B, 203THA, URIC, DH63, W76, MX40, U1923, CY32, Z14, DD620, 2X2, 3B7. EXPORT. We are fully equipped for safe packing and despatch from the smallest item to bulk. All orders immediately despatched and fully insured. STOP PRESS PORTADYNE RADIOGRAM in stock. SHIEP1, Highfidelity, Moving Coil, Pick-up, £2/10/4. G.L.D. RIGID PICK-UP, Conv. 12A5, your old gramophone into Radiogram quality, 28/-. VID-R POWER UNIT converts all dry portables into mains A.C. (plug unit in), £5/15/-. Please write immediately to BULLS (W.W.) above address

MIDLAND INSTRUMENT Co. OFFER GOVT. SURPLUS STOCK

AMERICAN ANAPI CATHODE RAY UNITS, 11, valve amplifier power pack, 34in. C.R. tube, control unit, etc., with instructional booklet and data, used from 230-v. A.C. brand new in sealed cartons, £5, carriage paid. ELIMINATORS, A.C. input 200/250-v. D.C. output 120-v. 30-m.A., fitted neon stabilizer, brand new, 40/-. MOTORS fitted centrifugal pump 12/24-v. A.C./D.C. for liquids, brand new, 35/-. MOTORS, 12-v. A.C./D.C. takes 4-amp, fitted gear-box, powerful final drive 1,000-r.p.m., 25/-, post 1/4. MAINS MOTORS, 200/250-v. A.C./D.C. takes approx. 1-amp, (converted motor generators) fitted (in shaft), 30/-. GENERATORS (D.C. dynamo) output 12-v. 750-watt, 30/- carriage 5/-. also 24-v. 1,000-watt output, 40/- carriage 10/- extra. 1155 RECEIVER twin-knob slow-motion drives, 210-1, brand new, 5/-, post 6d. B.T.H. CRYSTAL VALVE RECTIFIERS C87-A, brand new in lead capsules, 8/6, post 3d. BROWNS 4,000-ohm HEADPHONES, brand new 10/-, post 1d. CLOCKS, aircraft dashboard mtg., luminous, rim wind, trip hand set, 2 1/2in. dia., brand new boxed, 70/-, post paid. G.P.O. TYPE RELAYS, 1,000-ohm, single make, 1/-, 10/- doz. U.S. ARMY BLASTING MACHINES (10-cap), a very neat hand type A.C. generator, worth £10, brand new boxed, 25/-, post 1/4. PLUGS with jacks to fit, 2-way, 1/6, 4-way, 2/6. TONES 6-WAY PLUGS with sockets to fit, 2/6. MICROPHONES, carbon type, hand types bakelite case fitted switch, brand new, 2/6, 24/- doz. OXYGEN FLOW INDICATORS, brand new boxed 1/6. MAGNETIC COMPASS variation correctors, 1/6. D.R. COMPASS accessories, variation correctors 15/-, pilots' repeater compasses, 25/-. CAMERA CONTROLS, 12-v., contains motor, clockwork escapement, 1/50 sec. timing device, counter 0-125, etc., etc. brand new in wood cases, 25/-, post 1/4. Also hundred of other interesting Radio, Electronic and Mechanic. Items to offer, send for our current lists, 2d. with a.e. orders over 30/- post paid, carriage extra. Note increase in postage rates. No C.O.D. under 20/-.

Moorpool Circle, Birmingham, 17 Tel.: HARBONE 1308 or 2644

CALLING AMATEURS WITH BUCCLEUGH Precision Built Equipment STEEL CHASSIS SMOOTH BLACK 17" x 10 1/2" x 2 1/2" 9/9 17" x 10" x 2", 8/9 PANELS-CRACKLE 19" x 3 1/2" 4/- 19" x 7" 6/9 19" x 8 1/2" 7/9 19" x 10" 8/9 ANGLE BRACKETS, 12 1/2" long, pr. 7/6. (All in Bright Aluminium, same cost.) COMPLETE RACK ASSEMBLY (Rigid 4-Phillar), 63", £3/5s. 31 1/2", £2/5s. Chassis, etc., to order, 3d sq. incl. (Incl. valves when costing.) PUNCHING CHARGES UP TO 1 1/2". 2d. VALVE HOLES, 1", 1 1/4" or 1 1/2", 6d. METER HOLES, etc., 1/6. SQUARE HOLES, 2/-. BUCCLEUGH RADIO MANUFACTURERS 1 & 2 MELVILLE TERRACE, EDINBURGH 9 "Grams": "Therm.", Edinburgh, Factory: Wetherfield St., Edinburgh, G.

HIGH "Q" IRON CORED COILS

of Unsurpassed Quality for Discerning Amateurs

AERIAL, H.F. OR OSCILLATOR, short, medium or long wave, size of former 1in. x 1/2in. 3/9 each. INPUT FILTER, 465 Kc/s., parallel or series tuned, 3/9 each.

I.F. TRANSFORMERS, 465 Kc/s., midjet, permeability tuned, size 1in. diam. x 1 1/2in. high, 9/6 each.

I.F. TRANSFORMERS, standard, 465 Kc/s., permeability tuned, size 1 1/2in. square x 3 1/2in. high, 8/6 each.

All coils fitted with adjustable iron cores, and supplied with circuit diagram.

TERMS: Cash with order or C.O.D. on orders over £1.

TRADE ENQUIRIES INVITED.

MONOCHORD RADIO

(Established 1929)

17 Streatham Hill, London, S.W.2

Phone: Tulse Hill 1051/2.

CRYSTALS

FOR
**AIRCRAFT
MARINE
AND
AMATEUR
TRANSMITTERS**

ALL LOW TEMP. CO-EFF. CUTS.

BROOKES CRYSTALS LTD.

51/53, GREENWICH CHURCH ST.,
GRE. 1828-0410. LONDON, S.E.10.

HIGH FIDELITY

A much improved version of our Corner Cabinet is now available, in either whitewood or walnut veneer. Full details on request. Our Feeder Units and Amplifiers are now available from stock.

A prototype miniature Hl. Fl. receiver and amplifier using button base valves is in course of development and will soon be demonstrated in our showrooms.

Components for the Partridge 15 Watt Quality Amplifier are available from stock. Our Price List covering components for High Fidelity equipment will be forwarded on request.

ROGERS DEVELOPMENTS CO.

12, MACCLESFIELD STREET,
SHAFTESBURY AVENUE, W.1.

Telephone: GERrard 3057, 8256.

COVENTRY RADIO

COMPONENT SPECIALISTS SINCE 1925

Microamp Meters. 20-0-20 UA., 3 1/2in. scale, Edgewise type. Special Offer £3/6.-. T.C.C. Condensers. Full range of metal Electrolytics, Tubular Paper and Mica.

Volume Controls. Twin Gang, replacement for Marconi 262, 286, etc., 9/-.

I.F. Transformers. 465 kcs. Per pair 12/6, 15/-, 17/6 and 20/-. All list grade.

Only best quality components for Home Constructors, Development and Service Engineers. Send for our list. 3d. post paid.

Prompt Service. Complete Satisfaction.

COVENTRY RADIO

191, Dunstable Road, Luton, Beds.

Phone: LUTON 2677



Beethoven
ROTARY CONVERTORS
220 D.C. to 220 A.C.
Details from—
BEEHOVEN ELECTRIC EQUIPMENT LTD.
Beethoven Works, Chase Road, London, N.W.10

A.B. OAK wafer switches

The wave-change switch with silver-plated double contacts.

A.B. METAL PRODUCTS LTD.,
Great South-West Road, Feltham, Middx.

L-R-S IN STOCK AVOMETERS

Model 7	Cash price	£19 10 0
Avomitor AC/DC Universal meter		£8 10 0
Valve Taster, complete		£16 10 0
Avomitor DC meter		£4 4 0
Oscillator, mains		£13 0 0

Enquiries for other models are invited.
Stuart Centrifugal Electric Pumps for all pumping purposes. Compact and Efficient. All sizes again available. Please write for specification.

Morphy Richards Auto Electric Irons. Chrome superb quality 39/6 post 1/-.

All the above available on convenient terms.

Illustrated list of any of the above items 1/-.

The LONDON RADIO SUPPLY CO.
(The L.R. Supply Co. Ltd.) Est. 1925
BALCOMBE SUSSEX

OLDCHURCH LABORATORIES

T.S.73. We have prepared a complete set of four blueprints and instruction booklet covering the conversion of this unit to a normal oscilloscope. Price £1.

A limited number of ready converted units are available at £20 each. These are the equal of any oscilloscope at present on the market, being complete with power unit, amplifier, and all necessary controls.

New Instruments from stock. Avometer Model 7, £19 10/0; Avometer Mains Sig. Gen., £13 0/0; Avometer Valve Tester, £16 10/0; Taylor 70a Meter £11 11 0; Taylor 80a (20K, O. P. V.), £19 19 0.

Used Instruments, New condition. Avometer Model 7 (3 months old) £16 0/0. Weston E.772, complete in case (2 months old) £19 0 0

Consult us on all your instrument problems. We buy, sell, overhaul, and recalibrate all Test Equipment.

L. P. DISMORE
(formerly MORTON & DISMORE)
52c OLDCHURCH RD., CHINGFORD, E.4
Phone: SIL 4987

WE OFFER

A large range of used and new Test Equipment, Converters, Recorders, Amplifiers, Motors, Transformers, etc.

All guaranteed and at very attractive prices.

We buy good modern used equipment of all types for spot cash.

UNIVERSITY RADIO LTD.

22 LISLE STREET, LONDON, W.C.2.
Tel.: GER 4447 & 8582.

MOVING COIL HAND MICROPHONES (No. 13)

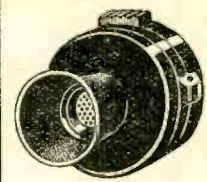

Bakelite case 2 1/2" diam. Press-to-talk switch. Soft rubber mouth-piece. Coil 40 ohms d.c. res. Excellent performance. Brand new, in original packing. Including postage, 5/- each, or case of ten for 40/-. Despatched same day.

Miniature 20:1 Hyperlo matching Transformers for above, 7/6d. Packing and postage, if ordered separately, 9d. extra.

WIRELESS SUPPLIES UNLIMITED
(Props. Unlimitex Radio Ltd.)
264-266, Old Christchurch Road,
BOURNEMOUTH, Hants

MORSE CODE TRAINING



There are Candler Morse Code Courses for **BEGINNERS AND OPERATORS.**

Send for this Free "BOOK OF FACTS" It gives full details concerning all Courses.

THE CANDLER SYSTEM CO.,
Room 55W, 121 Kingsway, London, W.C.2
Candler System Co., Denver, Colorado, U.S.A.



THE SERVICE ENGINEER'S FIRST CHOICE

TELEVISION

The advance in Radio Technique offers unlimited opportunities of high pay and secure posts for those Radio Engineers who have had the foresight to become technically qualified. How you can do this quickly and easily in your spare time is fully explained in our unique handbook "Engineering Opportunities". Full details are given of A.M.I.E.E., A.M.B.I.I.R.E., City & Guilds Exams., and particulars of up-to-date courses in Wireless Engineering, Radio Servicing, Short Waves, Television, Mathematics, etc., etc.

We Guarantee "NO PASS—NO FEE" Prepare for to-morrow's opportunities and future competition by sending for your copy of this very informative 112-page guide NOW—FREE.

BRITISH INSTITUTE OF ENGINEERING TECHNOLOGY (Dept. 388)
17, Stratford Place, London, W.1